

Improvement of Power Quality by Using Distributed Power Flow Controller for different case studies

G. Gurumurthy¹, Chv. Ganesh², Gnv Sharath Babu³

¹JNTU University Pulivendula

²ST.PETER'S Engineering College, Hyderabad

³SVEC, Tadepalligudem

Abstract- According to growth of electricity demand and the increased number of non-linear loads in power grids, providing a high quality electrical power should be considered. In this paper, voltage sag and swell of the power quality issues are studied and distributed power flow controller (DPFC) is used to mitigate the voltage deviation and improve power quality. The DPFC is a new FACTS device, which its structure is similar to unified power flow controller (UPFC). In spite of UPFC, in DPFC the common dc-link between the shunt and series converters is eliminated and three-phase series converter is divided to several single-phase series distributed converters through the line. The case study contains a DPFC sited in a single-machine infinite bus power system including two parallel transmission lines, which simulated in MATLAB/Simulink environment. The presented simulation results validate the DPFC ability to improve the power quality.

Index Terms- FACTS, Power Quality, Sag and Swell Mitigation, Distributed Power Flow Controller

I. INTRODUCTION

In the last decade, the electrical power quality issue has been the main concern of the power companies [1]. Power quality is defined as the index which both the delivery and consumption of electric power affect on the performance of electrical apparatus [2]. From a customer point of view, a power quality problem can be defined as any problem is manifested on voltage, current, or frequency deviation that results in power failure [3]. The power electronics progressive, especially in flexible alternating-current transmission system (FACTS) and custom power devices, affects power quality improvement [4], [5]. Generally, custom power devices, e.g., dynamic voltage restorer (DVR), are used in medium-to-low voltage levels to improve customer power quality [6]. Most serious threats for sensitive equipment in electrical grids are voltage sags (voltage dip) and swells (over voltage) [1]. These disturbances occur due to some events, e.g., short circuit in the grid, inrush currents involved with the starting of large machines, or switching operations in the grid. The FACTS devices, such as unified power flow controller (UPFC) and synchronous static compensator (STAT-COM), are used to alleviate the disturbance and improve the power system

quality and reliability [7], [8].

In this paper, a distributed power flow controller, introduced in [9] as a new FACTS device, is used to mitigate voltage and current waveform deviation and improve power quality in a matter of seconds. The DPFC structure is derived

from the UPFC structure that is included one shunt converter and several small independent series converters, as shown in Fig. 1 [9]. The DPFC has same capability as UPFC to balance the line parameters, i.e., line impedance, transmission angle, and bus voltage magnitude [10].

The paper is organized as follows: in section II, the DPFC principle is discussed. The DPFC control is described in section III. Section IV is dedicated to power quality improvement by DPFC. Simulation results are presented in section V.

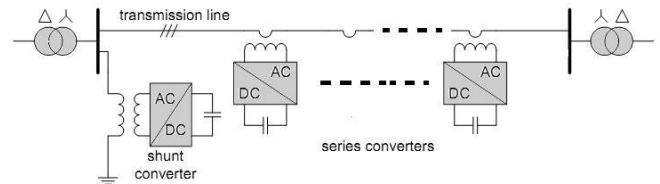

Fig.1.The DPFC Structure

II. DPFC PRINCIPLE

In comparison with UPFC, the main advantage offered by DPFC is eliminating the huge DC-link and instate using 3rd-harmonic current to active power exchange [9]. In the following subsections, the DPFC basic concepts are explained.

A. Eliminate DC Link and Power Exchange

Within the DPFC, the transmission line is used as a connection between the DC terminal of shunt converter and the AC terminal of series converters, instead of direct connection using DC-link for power exchange between converters. The method of power exchange in DPFC is based on power theory of non-sinusoidal components [9]. Based on Fourier series, a non-sinusoidal voltage or current can be presented as the sum of sinusoidal components at different frequencies. The product of

voltage and current components provides the active power. Since the integral of some terms with different frequencies are zero, so the active power equation is as follow:

$$p = \sum_{i=1}^{\infty} V_i I_i \cos \phi_i \quad (1)$$

Where V_i and I_i are the voltage and current at the i^{th} harmonic, respectively, and ϕ_i is the angle between the voltage and current at the same frequency. Equation (1) expresses the active power at different frequency components is independent. Based on this fact, a shunt converter in DPFC can absorb the active power in one frequency and generates output power in another frequency. Assume a DPFC is placed in a transmission line of a two-bus system, as shown in Fig.1. While the power supply generates the active power, the shunt converter has the capability to absorb power in fundamental frequency of current. Meanwhile, the third harmonic component is trapped in Y- Δ transformer. Output terminal of the shunt converter injects the third harmonic current into the neutral of Δ -Y transformer (Fig. 3). Consequently, the harmonic current flows through the transmission line. This harmonic current controls the DC voltage of series capacitors. Fig. 2 illustrates how the active power is exchanged between the shunt and series converters in the DPFC. The third-harmonic is selected to exchange the active power in the DPFC and a high-pass filter is required to make a closed loop for the harmonic current. The third-harmonic current is trapped in Δ -winding of transformer. Hence, no need to use the high-pass filter at the receiving-end of the system. In other words, by using the third-harmonic, the high-pass filter can be replaced with a cable connected between Δ -winding of transformer and ground. This cable routes the harmonic current to ground.

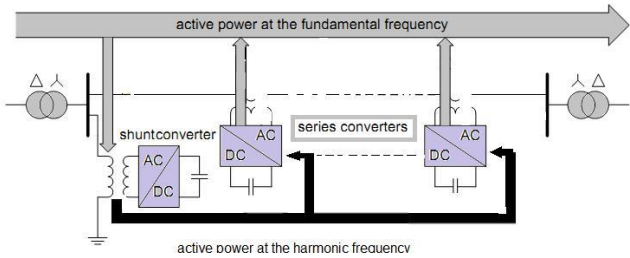

Fig. 2.Active power exchange between DPFC converters

B. The DPFC Advantages

The DPFC in comparison with UPFC has some advantages, as follows:

- *High Control Capability*

The DPFC similar to UPFC can control all parameters of transmission network, such as line impedance, transmission angle, and bus voltage magnitude.

- *High Reliability*

The series converters redundancy increases the DPFC reliability during converters operation [10]. It means, if

one of series converters fails, the others can continue to work.

- *Low Cost*

The single-phase series converters rating are lower than one three-phase converter. Furthermore, the series converters do not need any high voltage isolation in transmission line connecting; single-turn transformers can be used to hang the series converters.

Reference [9] reported a case study to explore the feasibility of the DPFC, where a UPFS is replaced with a DPFC in the Korea electric power corporation (KEPCO). To achieve the same UPFC control capability, the DPFC construction requires less material [9].

III.DPFC CONTROL

The DPFC has three control strategies: central controller, series control, and shunt control, as shown in Fig. 3.

A. Central Control

This controller manages all the series and shunt controllers and sends reference signals to both of them.

B. Series Control

Each single-phase converter has its own series control through the line. The controller inputs are series capacitor voltages, line current, and series voltage reference in the dq-frame. The block diagram of the series converters in Matlab/Simulink environment is demonstrated in Fig. 4.

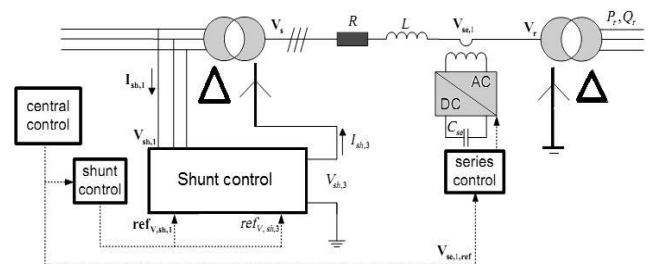

Fig. 3. DPFC control structure

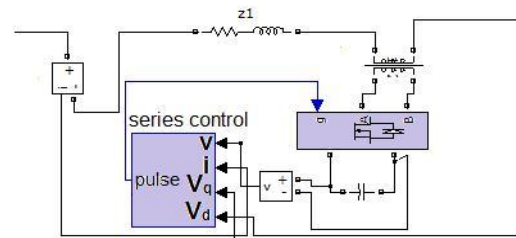

Fig.4.Block diagram of the series converters in Matlab/Simulink.

Any series controller has a low-pass and a 3rd-pass filter to create fundamental and third harmonic current, respectively. Two single-phase phase lock loop (PLL) are

used to take frequency and phase information from network [11]. The block diagram of series controller in Matlab/Simulink is shown in Fig. 5. The PWM-Generator block manages switching processes.

C. Shunt Control

The shunt converter includes a three-phase converter connected back-to-back to a single-phase converter. The three-phase converter absorbs active power from grid at fundamental frequency and controls the dc voltage of capacitor between this converter and single-phase one. Other task of the shunt converter is to inject constant third-harmonic current into lines through the neutral cable of Δ-Y transformer.

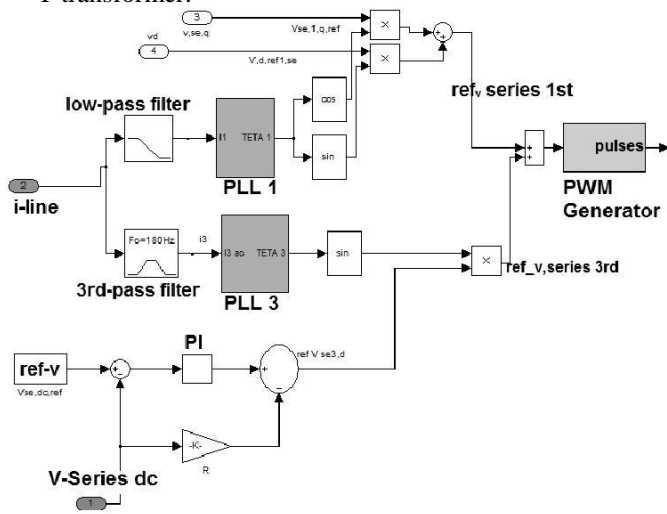

Fig.5. Block diagram of series control structure in Matlab/Simulink

Each converter has its own controller at different frequency operation (fundamental and third-harmonic frequency). The shunt control structure block diagram is shown in Fig. 6

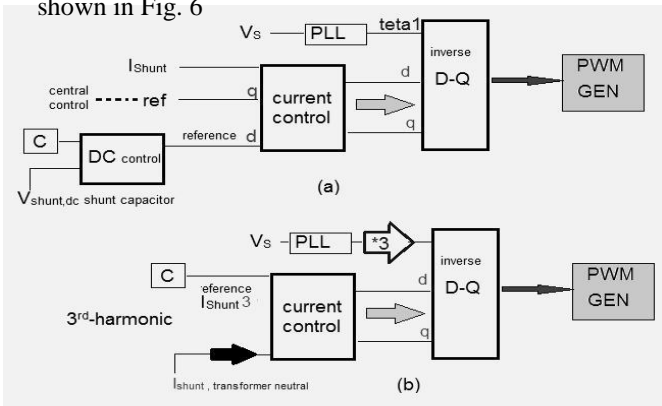

Fig.6. The shunt control configuration: (a) for fundamental frequency (b) for third-harmonic frequency

IV. POWER QUALITY IMPROVEMENT

The whole model of system under study is shown in Fig. 7. The system contains a three-phase source

connected to a non-linear RLC load through parallel transmission lines (Line 1 and Line 2) with the same lengths. The DPFC is placed in transmission line, which the shunt converter is connected to the transmission line 2 in parallel through a Y-Δ three-phase transformer, and series converters is distributed through this line. The system parameters are listed in appendix TABLE I.

To simulate the dynamic performance, a three-phase fault is considered near the load. The time duration of the fault is 0.5 seconds (500-1000 millisecond). As shown in Fig. 8, a significant voltage sag is observable during the fault, without any compensation. The voltage sag value is about 0.5 per-units. After adding a DPFC, load voltage sag can be mitigated effectively, as shown in Fig. 9.

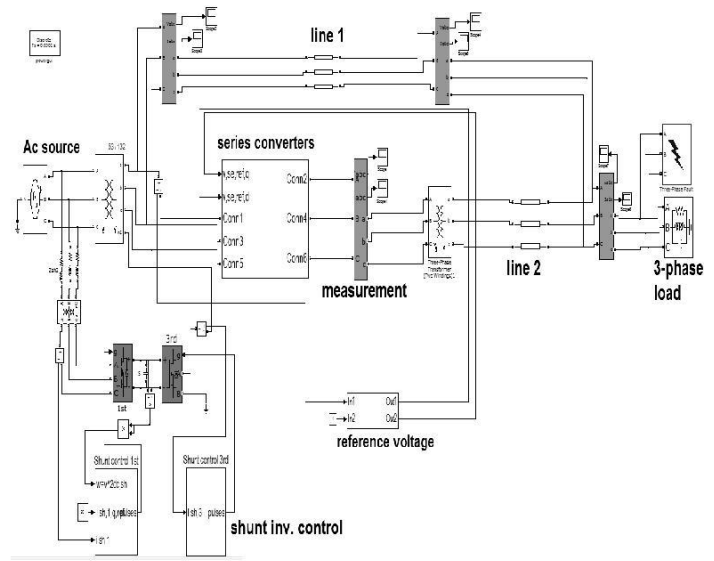

Fig.7. Simulation model of the DPFC

V. EXAMINING SIMULATION RESULTS

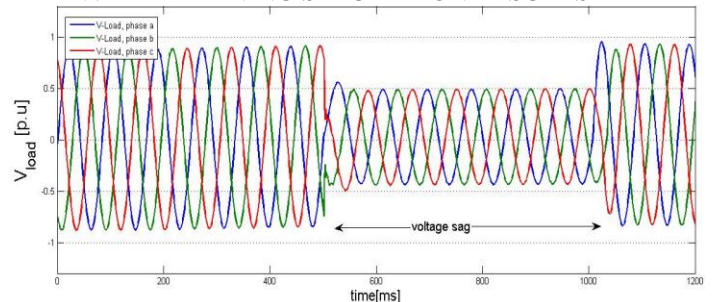

Fig.8. Three-phase load voltage sag waveform

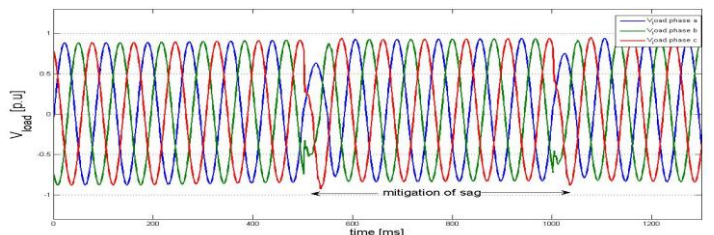

Fig.9. Mitigation of three-phase load voltage sag with DPFC

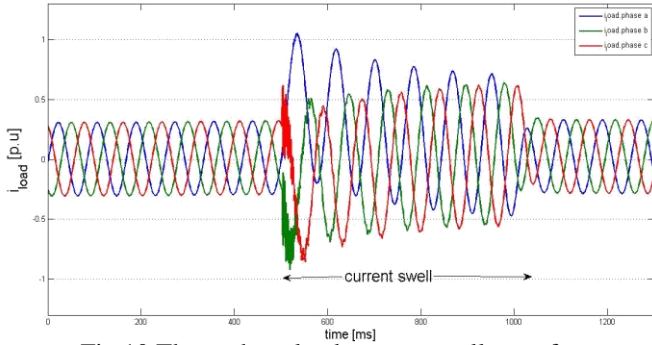

Fig.10.Three-phase load current swell waveform without DPFC

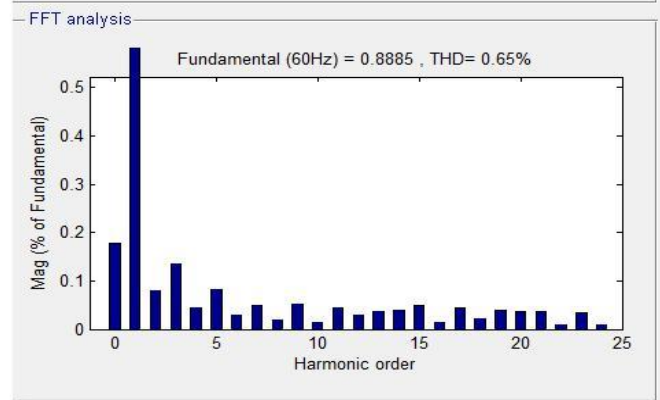

Fig.13.Total harmonic distortion of load voltage with DPFC

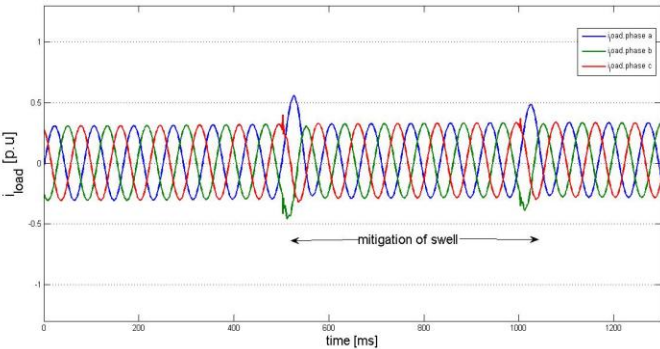

Fig.11.Mitigation of three-phase load current swell with DPFC

The load voltage harmonic analysis without presence of DPFC is illustrated in Fig. 12. It can be seen, after DPFC implementation in system, the even harmonics is eliminated, the odd harmonics are reduced within acceptable limits, and total harmonic distortion (THD) of load voltage is minimized from 45.67 to 0.65 percentage (Fig. 13), i.e., the standard THD is less than 5 percent in IEEE standards.

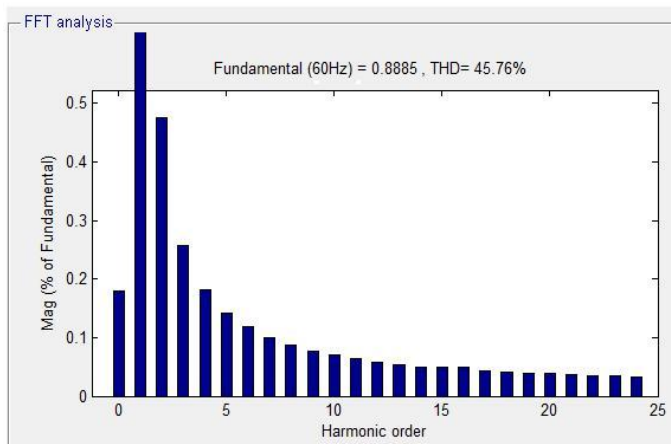

Fig.12.Total harmonic distortion of load voltage without DPFC

VI. CONCLUSION

To improve power quality in the power transmission system, there are some effective methods. In this paper, the voltage sag and swell mitigation, using a new FACTS device called distributed power flow controller (DPFC) is presented. The DPFC structure is similar to unified power flow controller (UPFC) and has a same control capability to balance the line parameters, i.e., line impedance, transmission angle, and bus voltage magnitude. However, the DPFC offers some advantages, in comparison with UPFC, such as high control capability, high reliability, and low cost. The DPFC is modeled and three control loops, i.e., central controller, series control, and shunt control are design. The system under study is a single machine infinite-bus system, with and without DPFC. To simulate the dynamic performance, a three-phase fault is considered near the load. It is shown that the DPFC gives an acceptable performance in power quality mitigation and power flow control.

APPENDIX

TABLE I. Simulation System Parameters

Parameters	values
Three phase source	
Rated voltage	230 kV
Rated power/Frequency	100MW/60HZ
X/R	3
Short circuit capacity	11000MW
Transmission line	
Resistance	0.012 pu/km
Inductance/ Capacitance reactance	0.12/0.12pu/km
Length of transmission line	100 km
Shunt Converter 3-phase	
Nominal power	60 MVAR

[11] R. Zhang, M. Cardinal, P. Szczesny and M. Dame. "A grid simulator with control of single-phase power converters in D.Q rotating frame", *PowerElectronics Specialists Conference, IEEE 2002*

<i>ZContinue of Table I :</i>	
Coupling transformer (shunt)	
Nominal power	100 MVA
Rated voltage	230/15 kV
Series Converters	
Rated voltage	6 kV
Nominal power	6 MVAR
Three-phase fault	
Type	ABC-G
Ground resistance	0.01ohm

REFERENCES

- [1] S. Masoud Barakati, Arash Khoshkbar Sadigh and Ehsan Mokhtarpour, "Voltage Sag and Swell Compensation with DVR Based on Asymmetrical Cascade Multicell Converter" , North American Power Symposium (NAPS), pp.1 – 7, 2011
- [2] Alexander Eigels Emanuel, John A. McNeill "Electric Power Quality". *Annu. Rev. Energy Environ* 1997, pp. 263-303.
- [3] I Nita R. Patne, Krishna L. Thakre "Factor Affecting Characteristics Of Voltage Sag Due to Fault in the Power System" *Serbian Journal Of Electrical engineering*. vol. 5, no.1, May2008, pp. 171-182.
- [4] J. R. Enslin, "Unified approach to power quality mitigation," in *Proc. IEEE Int. Symp. Industrial Electronics (ISIE '98)*, vol. 1, 1998, pp. 8– 20.
- [5] B. Singh, K. Al-Haddad, and A. Chandra, "A review of active filters for power quality improvement," *IEEE Trans. Ind. Electron.* vol. 46, no. 5, pp. 960– 971, 1999.
- [6] M. A. Hannan and Azah Mohamed, member IEEE, "PSCAD/EMTDC Simulation of Unified Series-Shunt Compensator for Power Quality Improvement", *IEEE Transactions on Power Delivery*, vol. 20, no. 2, April 2005.
- [7] A. L. Olimpo and E. Acha, "Modeling and analysis of custom power systems by PSCAD/EMTDC," *IEEE Trans. Power Delivery*, vol. 17, no.1, pp. 266– 272, Jan. 2002.
- [8] P. Pohjanheimo and E. Lakervi, "Steady state modeling of custom power components in power distribution networks," in *Proc. IEEE Power Engineering Society Winter Meeting*, vol. 4, Jan. 2000, pp. 2949–2954.
- [9] Zhihui Yuan, Sjoerd W.H de Haan, Braham Frreira and Dalibor Cevoric "A FACTS Device: Distributed Power Flow Controller (DPFC)" *IEEE Transaction on Power Electronics*, vol.25, no.10, October 2010.
- [10] Zhihui Yuan, Sjoerd W.H de Haan and Braham Frreira "DPFC control during shunt converter failure" *IEEE Transaction on Power Electronics* 2009.

AUTHORS



G.GURUMURTHY was born in kadapa ,india 1989.He received the b.tech degree in electrical and electronics engineering from JNTU Anantapur and m.tech degree in control systems from JNTU Hyderabad, India in 2010 and 2013 respectively.He worked as assistant professor in st.peters engineering college from 2012-2014.he is presently working as a lecturer in jntu university pulivendula.His areas of interest is micro grid.

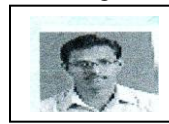

CHV GANESH was born in Ameerpet, Hyderabad, India. He received the b.tech degree in electrical and electronics engineering from JNTU Hyderabad and m.tech degree in control systems from JNTU Hyderabad, India in 2008 and 2012 respectively.He is presently working as an assistant professor in st.peters engineering college from 2011 to till date. His area of interest is fact controllers.



GNV.SHARATH BABU was born in Eluru, India 1984. He received the b.tech degree in electrical and electronics engineering Swarnandhra College of Engineering and Technology and M.tech degree in control systems from JNTU Hyderabad, India in 2006 and 2011 respectively. He is presently working as an assistant professor in SVEC-Tadepalligudem.