

Study air flow while air passes through a restricted path of conical annulus energy losses occurs at the wall boundaries

Akash Zagade¹, Ganesh Thopate², Swapnil Raut³, Sangram Nalawade⁴, Prof. S. B. Taware⁵
^{1,2,3,4}BE MECH Students SVPM'S College of Engineering Malegaon (BK) Baramati Dist- Pune.

⁵Assistant Professor Mechanical Department SVPM'S College of Engineering Malegaon (BK), Baramati.

Abstract— In this project it is proposed to study experimentally the air flow while air passes through a restricted path of cylindrical annulus energy losses occurs at the wall boundaries (shear loss), interference etc. Also flow becomes three dimensional flow which changes momentum of fluid in radial and axial direction. Study of this behavior of fluid is done through this experimentation. Diffusers are used in many fluid flow systems where a need exists for the flow deceleration or pressure enhancement. A wide angle diffuser has larger diffusion angle and area ratio than the common diffuser. Its main use is to restrict length of the diffusing passage for nearly equivalent pressure recovery enhancement. When the flow enters the diffuser inlet it faces an adverse pressure gradient that results in flow separation which causes degradation in the performance of a diffuser by decreasing the pressure rise capability and increasing the total pressure loss. Its performance depends on a complicated interaction between its flow and performance parameters. The energy transfer in these turbo machineries involves the exchange of significant levels of kinetic energy in order to accomplish the intended purpose. As a consequence, very large levels of residual kinetic energy frequently accompany the work input and work extraction processes, sometime as much as 50% of the total energy transferred. A small change in pressure recovery can increase the efficiency significantly. Therefore diffusers are absolutely essential for good turbo machinery performance. The geometric limitations in aircraft applications where the diffusers need to be specially designed so as to achieve maximum pressure recovery within the shortest possible length led to the development of annular diffusers.

Index Terms- Divergence angle, Annular diffuser, Diffusion angle, Pressure recovery.

I. INTRODUCTION

Diffuser forms an important part of most fluid flow systems where kinetic energy of flow needs to be converted into pressure energy by decelerating the flow in the direction of fluid motion with a simultaneous increase in static pressure. Wide angle diffuser is commonly used in many industries as it allow a short and rapid transition from inlet ducting to a collector of larger cross section. It is a short diffuser, with a large area ratio and a large equivalent cone angle. It provides excellent performance in low flow situations and their dump-resistant performance makes them well suited for cold air applications. Annular diffusers are often used in turbo-

machines as exducers in turbines, diffusing elements in compressors and interstage ducts in multi-stage turbines.

The design and performance of these diffusers are dependent on large number of geometrical and fluid dynamical parameters; if they are not carefully designed the flow pattern within them frequently shows large energy losses and stall. The flow pattern is further complicated if the flow entering such diffusers is swirled, which is commonly the case for flow leaving turbo machines rotors. In view of adverse pressure gradient and the complexity of the flow pattern in annular diffusers with swirled flow, a complete theoretical flow analysis through annular diffusers is rarely possible. Therefore, experimental methods have been of great importance for achieving some understanding of the flow behaviour.

In view of the wide applications of annular diffusers, the understanding of such diffuser flows is of paramount importance. A survey of annular diffuser research literature reveals that considerable investigations have been carried on number of geometrical variations of these diffusers handling incompressible, non-swirling flows.

Today, and for the majority of the near future, turbines will dominate the field of energy production that today turbo-powered electricity generation dominates the market at over 96 per cent of all means of electricity generation. In fact, the turbine market will not even drop one per cent by the year 2030. These efforts have been under way for some time now, with advancements in turbine technologies coming out quite regularly. Improvements are usually sought in areas where efficiencies can be raised; and this often leads to research in aerodynamic losses from current designs.

The penalty from aerodynamic losses can be quite large, and even a one per cent rise in turbine efficiency can be a substantial improvement in the turbine industry. Following these principles, the current research focused on characterizing the flow in a specific portion of the turbine where aerodynamic losses are impeding technology advancements. The diffuser portion at the exit of the compressor as the flow makes its way into the duct was studied.

II. EXPERIMENTAL

A) EXPERIMENTAL SETUP

An open loop wind tunnel was built such that the diffusers could be attached at the exit of centrifugal compressor. Figure shows a schematic of the experimental test rig. The flow was supplied by a Centrifugal Compressor. Outlet of compressor has flange diameter equal to 60mm. Following the venturi was a plenum that helped diminish any instability in the flow coming from the blower. A 60mm diameter pipe came out of the blower, made a 90 degree turn and proceeded towards the diffuser. This distance upstream was sufficient enough to

ensure the flow was fully developed by the time it reached the diffuser inlet.

The experimental rig was designed for a uniform flow at the diffuser inlet it must be stated that the likely hood of this happening in practice, both in this experiment, and in industry applications is quite unlikely. The converging, diverging and pressure recovery sections are of 242mm, 475mm and 242mm respectively. The length of settling chamber is kept as 400mm. The diffuser with its all dimensions is as shown in figure. Also the details of cylindrical test section are as shown in figure.

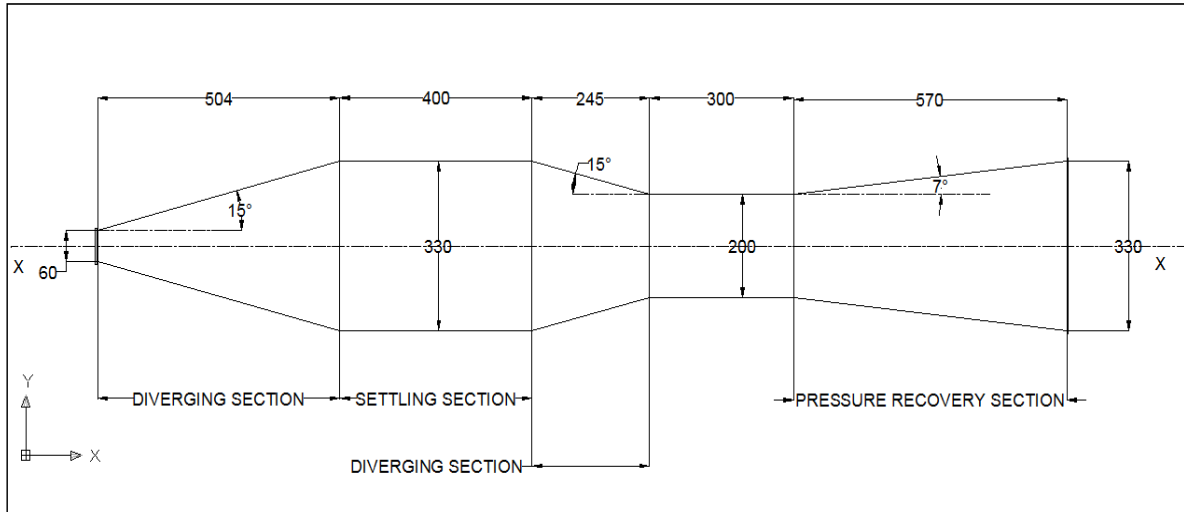

Fig. : Dimensions of Diffuser

B) SPECIFICATIONS OF TEST SET-UP

Specifications of Blower :

- Blower type: Radial Flow Blower
- Input power : 1.5 kW (2HP)
- Maximum pressure: 0.6 kg/cm²
- Flow rate : 0.054 m³/sec
- Full load speed = 2900 rpm

Specifications of Runner:

- Runner type : Axial flow runner
- Ratio of hub diameter to tip diameter : 0.5
- Length of runner blades along axis : 100 mm
- Diameter of shaft : 12 mm

Specifications of Diffuser:

- Blower outlet flange diameter = 60mm
- Length of settling chamber = 400mm
- Length of cylindrical section = 300mm
- Angle for diffuser (2θ) = 300
- Diameter of settling section = 330 mm

C) Ambient Condition:

The experiment will be performed in the peak time of the summer month. The inlet and outlet temperature are noted down from the thermometer reading, and

wet bulb temperature (T_{wb1}) is from the psychrometer reading. The experiment was carried out on the ambient temperature of T_a °C, wet bulb temperature (T_{wb1}) °C and relative humidity (RH) %.

Specific volume = (V_s)(From Psychrometric Chart)
 Density = $\rho = 1 / V_s$ kg/m³

D) Mass flow rates of air

The inlet and outlet velocities of air through the pad are measured and Volume flow rates are calculated by considering the density at selected ambient condition. The velocities of air through the duct are in m/s. The mass flow rate of air is calculated by the formula on the basis of the cross section area of the duct at inlet and outlet section, velocity of air and density.

$$M_a = \rho \times V_f$$

E) Losses in the duct:

Pressure losses:

Pressure loss in the flow passage occurred due to friction between moving particles of air and the interior

surface such losses also called as friction losses. Dynamic loss of pressure occurs due to change in cross section of the duct and also due to change in direction of the duct.

Dynamic losses:

Dynamic losses are caused due to the change in direction or magnitude of velocity of the air in diffuser. The change in velocity magnitude or direction can be caused only by the accelerating or decelerating forces which may be internal or external. The loss of pressure is due to the loss of energy of the fluid in overcoming such dynamic forces resisting the changes.

Friction losses:

Friction loss is the loss of head that occurs in flow passage due to the effect of the air viscosity near the surface of the duct. Such losses are also occurs due to rough surface of duct.

Shear losses:

These losses are due to shear movement between the layers of air passing very close to the flow area. Such losses are maximum at the passage surface and minimum at centre of the flow passage.

Turbulent losses:

Turbulence in air flow mainly cause due to the pressure difference at entry of the duct. So the turbulence causes the non-uniform flow of air and also responsible for rise in pressure in some region of the duct.

C) DESIGN AND DEVELOPMENT OF CONICAL SURFACES OF DIFFUSER

Inlet (Diverging) Section:

For this section,

Material Used: M.S. Plate

Cone angle (2θ) : 30°

Inlet diameter: 60 mm

Outlet diameter: 330 mm

Axial length: 504mm

We know that, angle made by developed surface with reference edge is given as,

$$\theta = \frac{r}{h} \times 360$$

$$\theta = \frac{165}{638} \times 360$$

$$\theta = 93.10^\circ$$

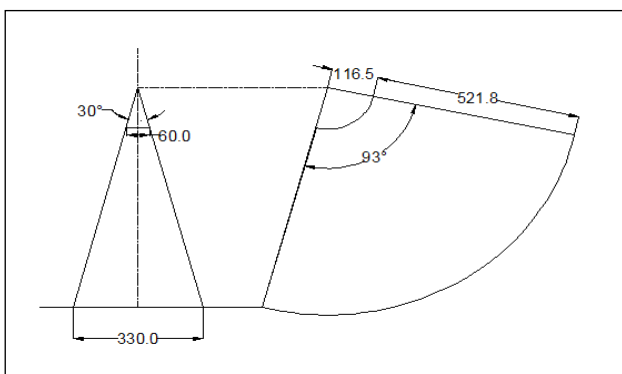

Converging Section:

For this section,

Material Used: M.S. Plate

Cone angle (2θ): 32°

Inlet diameter: 330 mm

Outlet diameter: 190 mm

Axial length: 226mm

We know that, angle made by developed surface with reference edge is given as,

$$\theta = \frac{r}{h} \times 360$$

$$\theta = \frac{165}{608} \times 360$$

$$\theta = 98^\circ$$

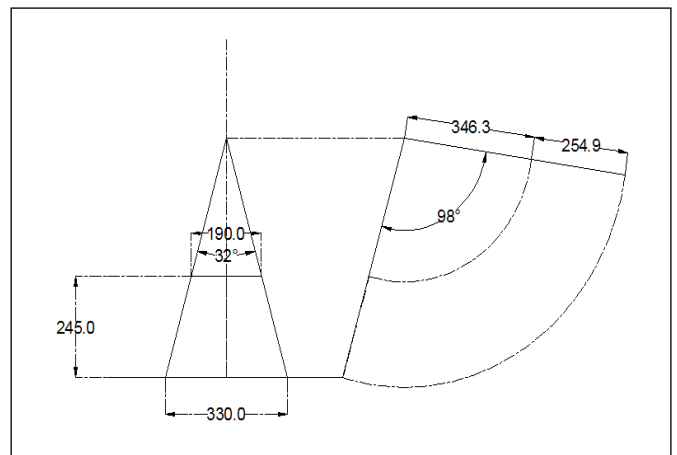

Pressure Recovery Section:

For this section,

Material Used: M.S. Plate

Cone angle(2θ): 14°

Inlet diameter: 190 mm

Outlet diameter: 330 mm

Axial length: 570 mm

We know that, angle made by developed surface with reference edge is given as,

$$\theta = \frac{r}{h} \times 360$$

$$\theta = \frac{165}{1410} \times 360$$

$$\theta = 42^\circ$$

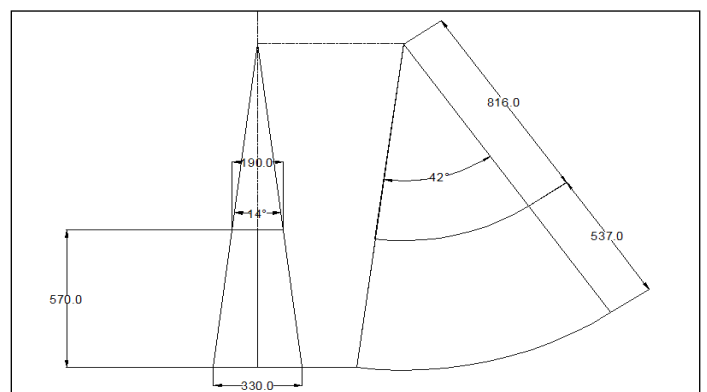

Annular Section:

For this section,
 Cone angle(2θ): 15°
 Inlet diameter: 150 mm
 Outlet diameter: 85 mm
 Axial length: 245 mm

We know that, angle made by developed surface with reference edge is given as,

$$\theta = \frac{r}{h} \times 360$$

$$\theta = \frac{75}{652} \times 360$$

$$\theta = 42^\circ$$

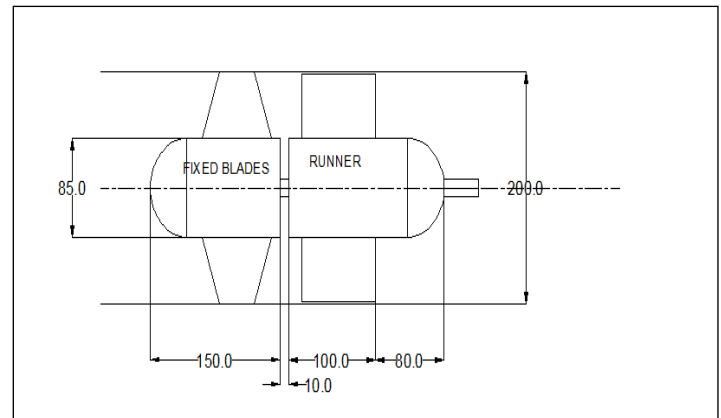

III. GEOMETRIC PARAMETERS

A) The Cause :

Diffusion can occur on isolated surfaces and within ducts, where for the desired reduction in flow velocity to occur the boundary layer must remain attached. At any point that separation occurs the main flow will form a jet that dissipates into turbulence, causing significant losses. In this regard, flows with laminar boundary layers at the inlet, or with thick turbulent boundary layers will not be capable of withstanding as much diffusion without separation as will thin turbulent boundary layers. Some work has been done using thin turbulent boundary layers to allow a larger amount of diffusion.

B) Things To Be Considered Before Choosing Diffuser:

The first is the effect of diffuser angle and area ratio of the diffuser has been investigated by testing two types of diffusers at five Reynolds numbers. This study is done by Dr. Basharat Salim at Department of Mechanical Engineering, College of Engineering, King Saud University Riyadh. Four diffusers of diffuser angle 5°, 7°, 10° and 12° were used to find the effect of diffuser angle, where as another four diffusers with area ratio 1.56, 1.76, 1.97 and 2.24 were used to determine effect of area enlargement for a diffuser angle of 7°. To achieve this goal an experimental facility was fabricated around a centrifugal fan which fed air diffuser through a settling chamber and a straight duct. The variations have been shown as velocity ratio with the references of the mean velocity at the inlet of the diffuser. The Reynolds numbers at which investigations were carried out were calculated using free upstream velocity which was measured upstream of the diffuser inlet so as to avoid the influence of the diffuser on velocity profile. The results depict that both the pressure recovery and diffuser effectiveness is better in the diffuser with 7° diffuser angle. The better performance is attributed to the lesser values of the

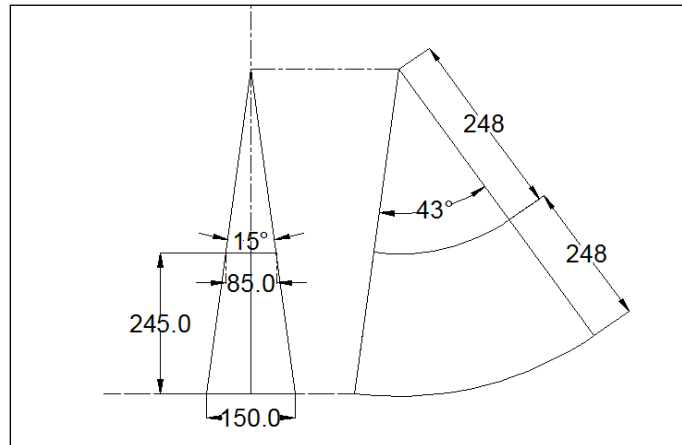

Settling Chamber :

For this section,
 Material Used: M.S. Plate
 Diameter of pipe : 330 mm
 Axial length: 400 mm

Cylindrical Test Section :

For this section,
 Material Used: Transparent Acrylic Pipe
 Inner diameter of pipe : 190 mm
 Thickness of pipe: 5mm
 Axial length: 300 mm

Fixed blades and runner :

For this section,
 Material Used: M.S. Plate
 Hub diameter : 85mm
 Length of fixed blades section : 150mm
 Length of runner : 180mm
 Clearance between fixed blades and runner : 10mm
 Axial length: 300 mm

inlet blockage and percentage RMS index for this diffuser. The change in the area ratio of the diffuser with diffuser angle of 7° showed that the change in the area ratio of the diffuser affects the performance parameters of the diffuser and the internal aerodynamics of the diffusers. The diffuser with aspect ratio of 1.76 developed higher pressure rise coefficient and diffuser effectiveness.

C) Variation of Velocity at the Inlet and Exit of Diffuser: Wide angle diffusers have found widened use in many flow systems therefore it is important to understand the flow within these. The variation is plotted in terms of the velocity ratio VR with non-dimensional width for different diffusers and at various Reynolds numbers. Velocity ratio V_R is the ratio of the velocity at any location at the inlet or the exit of the diffuser to the mass averaged velocity at the inlet V_i for a diffuser. The variation of this non dimensionalised velocity along the non dimensionalised width has is presented separately for showing the effect of diffusing angle and area ratio of diffuser with angle of 7° . The full lines depict the variation of this non dimensional total velocity at the inlet whereas the dashed lines represent the non-dimensional total velocity variation at the exit of the diffuser. The velocity variations at both the locations have been examined at five Reynolds numbers ranging from 22.3×10^5 to 23.7×10^5 but the results are presented only for one Reynolds number where as the discussion pertains to all the Reynolds numbers.

D) Effect of Diffusing Angle:

In these diffusers it is found that the velocity ratio decreases from the midpoint of to the diffusers to the bottom and the top of the diffuser. The steepness of the velocity profile is more on the bottom side of the diffuser as compared to the upper side of the diffuser passage. The steepness of the velocity profile in the upper half of the diffuser increases with the increase in the diffuser angle. The inlet velocity profiles are almost equally steep on upper and bottom half of the diffuser width. The exit velocity profiles show lesser variation along the width of the diffuser. The variations of the velocity profile are more predominant in 12° diffuser and least in 7° diffuser. The standard deviation at the inlet varies from 10% to 35% (with respect to mass averaged velocity at that location) in all the diffusers for all the Reynolds numbers whereas it varies from 5% to 25% at the exit. This typical character of 7° diffuser is also found in many other studies such as [15, 7]. It can be attributed to the fact that the better diffusing angle for a diffuser is 7° , less than this value will increase the

path length of the flow or the diffuser length, whereas more than this value would result in excessive separation beyond the inlet of the diffuser that would cause flow degradation and as a consequence a deficit in the performance of diffuser would be observed. The average velocity ratio becomes unity for the inlet profile as it should be but the exit profile changes at lower values of Reynolds number and then remains constant for higher values of the Reynolds numbers.

The performance improvement in this case occurs because the turbulence is intensified by the curvature of streamlines and the boundary layer along the casing is kept thin. For wide-angled diffusers ($2\theta = 30$ degrees), strong swirl is required to prevent the flow along the casing from separation. Moreover, the tendency for an increase in the pressure recovery coefficient with inlet swirl may be attributed to the resulting radial pressure gradients which bring about enhanced momentum exchange between the boundary layer and the mainstream, in addition to the created centrifugal force. For separated and near to separated flow diffusers ($2\theta = 16$ and 30 degrees), the static pressure recovery increases gradually along the diffuser with increasing the hub speed.

E) Effect of Area ratio:

In these diffusers it is evident that the velocity ratio at the inlet of these diffusers decreases toward the bottom face of the diffuser and velocity tries to smoothen out towards the top face of the diffuser. The linearity is more evident at higher Reynolds numbers and also for diffusers with higher area ratio. At lowest Reynolds number the steepness of the velocity profile is more on the bottom face of the diffusers as compared to the upper face of the diffuser passage. At the inlet a consistent mild steep in the velocity profile is also observed in all the diffusers after $y/W = 0.1$. The variation in the area ratio of the diffuser shows a little variation at the velocity profile magnitudes along the height of the diffuser. At the exit as expected the variation in the velocity is high but the steep for all the diffusers is evident more near the bottom face of the diffuser. For most of the passage height the velocity is more or less uniform for any diffuser particularly for diffusers with area ratio 1.97 and 2.24. The variation between the diffusers is large which seems due to the difference in the flow behaviour within these diffusers due to enlargement of the passage length. The magnitude of velocity along the length of the diffusers increases with the increase in area ratio from 1.56 to 1.76 and then decreases.

As the Reynolds number increase the velocity at the inlet of diffusers becomes non uniform and becomes

centric whereas the velocity at the exit of the diffuser become almost uniform for most of the height of the diffuser except at the bottom side of the diffuser where it falls. Most changes in the flow pattern are observed at the inlet of diffusers for the highest Reynolds number. The results of 30-diffusers ($A_R = 2.5$ and 3.5), had an appreciable region of separation with non-swirling inlet flow which is indicated by a constant pressure region. This indicates that, adding weak swirl to the axial flow in an annular diffuser is effective to improve the pressure recovery of unstalled flow and flow close to a separating condition, as in conical diffuser.

IV. CONCLUSIONS

1. Blockage factor is least for diffuser with 7° diffuser angle both at the inlet and the exit of the diffuser and it shows a tendency of decrease with increase in area ratio of the diffuser.
2. At the exit the RMS values for all Reynolds number remains almost invariant with change diffuser angle. Further its values increase with the increase in the Reynolds number and it shows a decreasing trend with the increase in area ratios of the diffuser.
3. The relative variations in the total velocity are more effected by the diffuser angle rather than the area ration of the diffuser. Further the variation in the total pressure loss coefficient decreases as the Reynolds number increases and it is more for lower area ratio diffusers.
4. The pressure recovery coefficient is consistently higher for the diffuser with 7° diffuser angle for all the Reynolds numbers. Also the diffuser with higher area ratio show higher values of pressure recovery compared to the lower area ratio diffusers.
5. The diffuser efficiency of diffuser with diffusing angle of 7° is found higher than all the other diffusers at all the Reynolds numbers. Diffuser efficiency seems to be more influenced by the Reynolds number than the area ratio of these diffusers.
6. The horizontal parallel wall shows higher values for maximum wall static pressure as compared to the diverging vertical wall of the diffusers. Further for the diffusers, with the change in the area ratio of the diffuser, the maximum value of wall static pressure shows a decreasing trend with the increase in Reynolds.

REFERENCES

Journals / Conference Papers:

- 1) R. Keerthana, G.Jamuna Rani, "Flow analysis of annular diffusers", International Journal of Engineering Research and Applications (IJERA) ISSN: 2248-9622 www.ijera.com Vol. 2, Issue 3, May-Jun 2012, pp.2348-23512348

- 2) Sovran G., Klomp E.D., "Experimentally determined optimum geometries for rectilinear diffusers with, conical or annular cross-section", Fluid Dynamics of Internal Flow, Elsevier Publishing Company, 2007.
- 3) Adkins R.C., "A simple method for design optimum annular diffusers". ASME Paper No. 83-GT-42, 1983.
- 4) Dr. Basharat Salim, Department of Mechanical Engineering College of Engineering, King Saud University Riyadh, "Effect of geometrical parameters on the performance of wide angle diffusers", Vol. 2, Issue 9, September 2013.
- 5) J. H. Horlock, Cambridge University, "Calculation of the annulus wall boundary layer in axial flow turbo machines".
- 6) R. I. Lewis, English Electric Co. Ltd., "Annular cascade experimental investigations of conical actuator disc theory and of non-uniform flow through plane walled diverging and or converging ducts", C.P.No. 766.
- 7) Christopher D. King, The university of Alabama, Tuscaloosa, "Computational analysis of diffuser performance for subsonic aerodynamic research laboratory wind tunnel", vol.7, No.4, pp.419-432 (2013).
- 8) H. A. Abdalla, Z. M. Omara, Tanta University, Tanta, Egypt, "Experimental performance analysis of annular diffuser with and without swirl", Seventh International Congress on fluid dynamics and propulsion, Dec 18-20, Cairo, Egypt.
- 9) Johannes Walter, Dieter Wurz, Institute of fluid machinery, Baden-Baden, Germany, "Experimental investigation of an annular diffuser for axial flow fan configuration at different inflow profiles", Vol. 20, Suppl. 6, pp. S1-S14, 2016.
- 10) Wilson, D. G. 1984, The Design of High-Efficiency Turbo machinery and Gas Turbines. The MIT Press, Cambridge, MA. pp.147-187.

Books:

- 1) David J. Cerantola, "Evaluation of swirl and tabs in short annular diffusers", Queen's University Kingston, Ontario, Canada, May 2014.
- 2) Murlidhar Biswas, "Advanced fluid dynamics and machinery", Volume II, pp. 404-458, Edition 1998.

Handbooks:

Design Data Book: PSG, 2000 Edition.