

# Intelligent Security Platform for Multiple Access Controls

Chintha Prasad<sup>1</sup>, Mylapoor Madhu<sup>2</sup>

<sup>1</sup>Dept of MCA, SKIIMS, Kapugunneri, Srikalahasti, AP, India

<sup>2</sup>Dept of MCA, SKIIMS, Kapugunneri, Srikalahasti, AP, India

**Abstract-** Our lives are filled with account numbers, passwords, PIN codes, and other pieces of confidential information that we need to remember and keep track of. Passwords for credit cards, bank accounts, confidential photos, music and video, very valuable scanned copies, driving's license and passport numbers, and insurance policy numbers are just a sampling of what we need to keep track of. Due to our busy life cycle we cannot remember all of them. In order to provide a very elegant and powerful solution to this problem this project called "Intelligent Security Platform for Multiple Access Controls" has been designed and developed. The philosophy is that we should be able to remember one password. The idea is to make that one password very secure and through that password we have access to all of our other passwords. This application can securely store Bank Account Information. It uses a powerful algorithm and implements a highly secure encryption mechanism. ISPMAC becomes an essential through its ubiquity, ease of use, security, and feature set. It uses one of the simplest and user friendly interfaces and can store more than just passwords. It provides a lower cost solution to provide a high security system to store all the confidential data.

**Index Terms-** ISPMAC, security, store all the confidential data.

## I. INTRODUCTION

The Intelligent Security Platform for Multiple Access Controls has been designed and developed. The philosophy is that we should be able to remember one password. So our lives are filled with account numbers, passwords, PIN codes, and other pieces of confidential information that we need to remember and keep track of. Passwords for credit cards, bank accounts, confidential photos, music and video, very valuable scanned copies, driving's license and passport numbers, and insurance policy numbers are just a sampling of what we need to keep track of. Due to our busy life cycle we cannot remember all of them. The idea is to make that one password very

secure and through that password we have access to all of our other passwords. This application can securely store Bank Account Information. It uses a powerful algorithm and implements a highly secure encryption mechanism. ISPMAC becomes an essential through its ubiquity, ease of use, security, and feature set. It uses one of the simplest and user friendly interfaces and can store more than just passwords. It provides a lower cost solution to provide a high security system to store all the confidential data.

## II. MODULES DESCRIPTION

- User Management Module
- Security System Module
- Personal Information Locker Module
- Bank Account Information Locker Module
- Image, Video and Music Locker Module

### 2.1 User Management

This module can be accessed by administrator. In this module administrator has to monitor the registered users. So the administrator has to provide approve or reject the registered users after communicating with the users. After approval also he can lock and un-lock the users. This administrator can view the list of locked and unlocked user at any time.

### 2.2 Security System

This module is used to provide the security for user stored information like their username, password and personal banking information and file information. By providing encryption mechanism we have to store the data in the database and by providing decrypting the data we have to provide view that data.

### 2.3 Personal Information Locker

This module can be accessed by users. In this module user can store their personal information like email id

& password, pan card details, passport details and driving license details and any time he can view & delete those details if he need. This module is dependent on Security system module to encrypt and decrypt the email id & password, pan card details, passport details & driving license details.

2.4 Bank Account Information Locker

This module can be accessed by users. In this module can store personal banking information's like bank account details, netbanking details & insurance policies details and he can view those details if he needed. This module is dependent on Security system module to encrypt & decrypt the details like bank account, net banking details & insurance policy details.

2.5 Image, Video and Music Locker

This module can be accessed by the users. In this module user can store the Images like scanned or normal copy of images, he can upload audio files which required security and ha canalso upload video files which required security. If the user required those stored images, audiofiles & video files can be download.

III. UML DIAGRAMS

UML stands for Unified Modeling Language. UML is a language for specifying, visualizing and documenting the system. This is the step while developing any product after analysis. The goal from this is to produce a model of the entities involved in the project which later need to be built. The representation of the entities that are to be used in the product being developed need to be designed. There are various kinds of methods in software design:

They are as follows:

- Use case Diagram
- Class Diagram
- Sequence Diagram
- Activity Diagram

3.1.1 Use Case Diagram

A Use case is a description of set of sequence of actions. Graphically it is rendered as an ellipse with solid line including only its name. Use case diagram is a behavioral diagram that shows a set of use cases and actors and their relationship. It is an association between the use cases and actors. An actor represents

a real-world object. Primary Actor–Sender, Secondary Actor Receiver.

3.1.2 Class Diagram

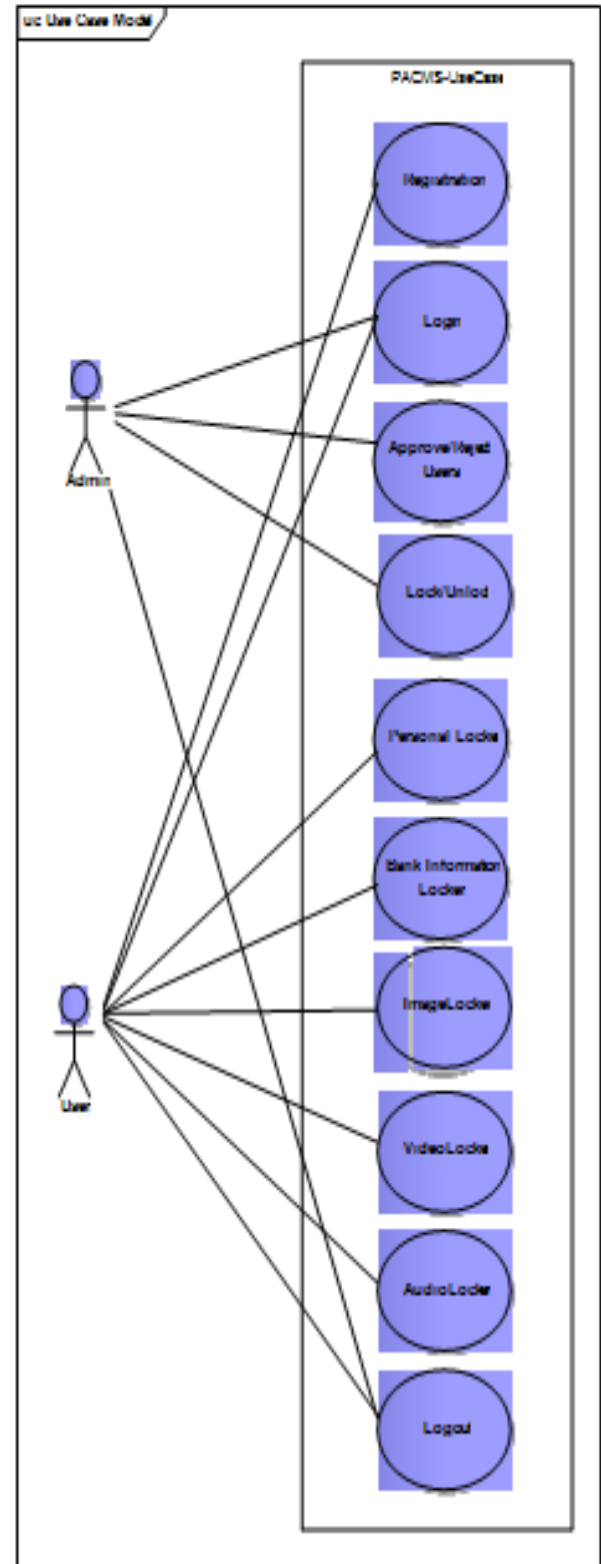

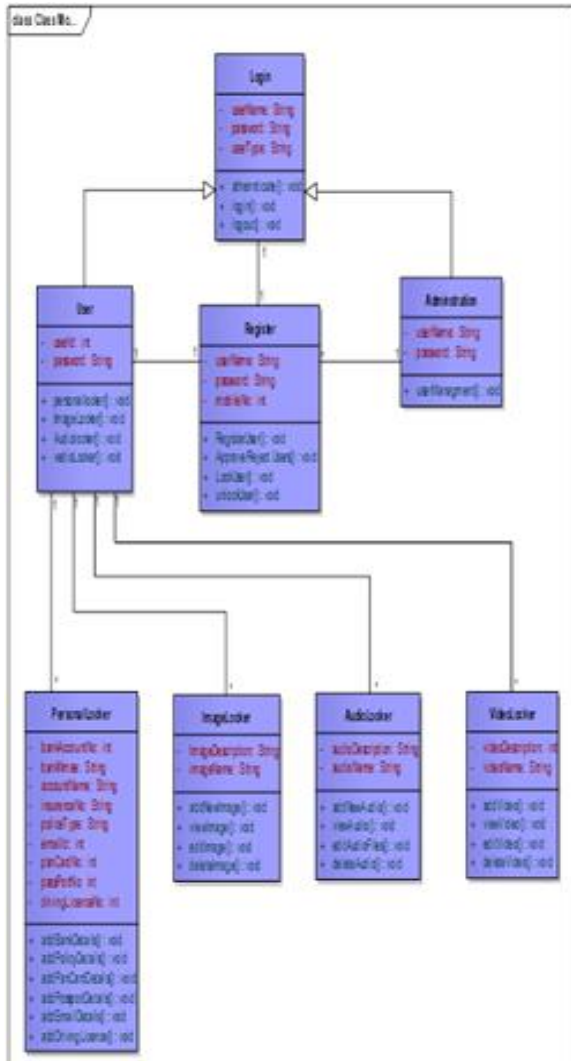

Sequence Diagram for Administrator

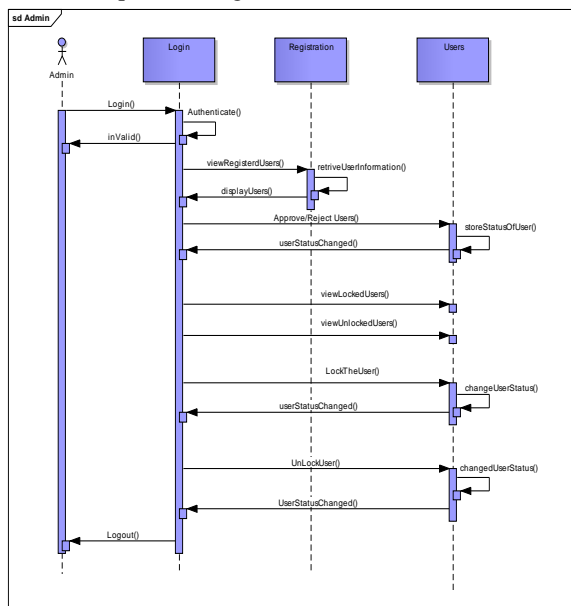

Sequence Diagram for User

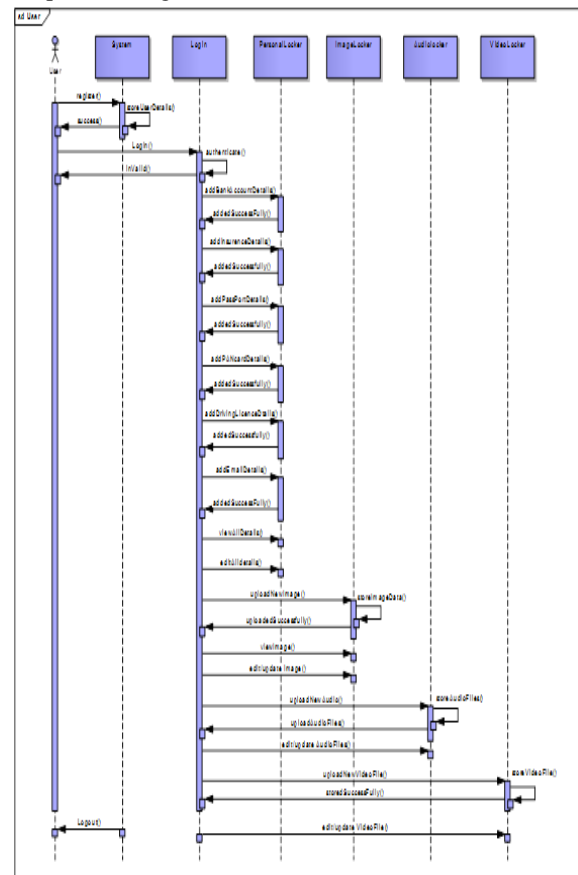

Fig: Activity Diagram for Administrator

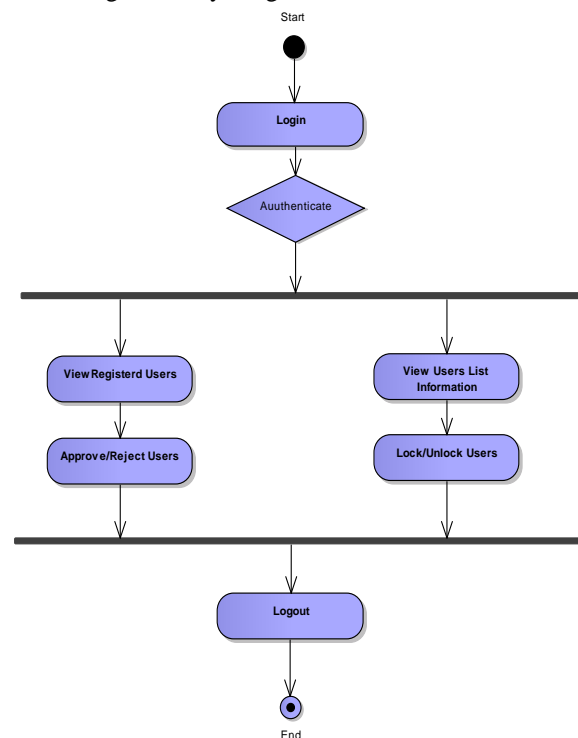
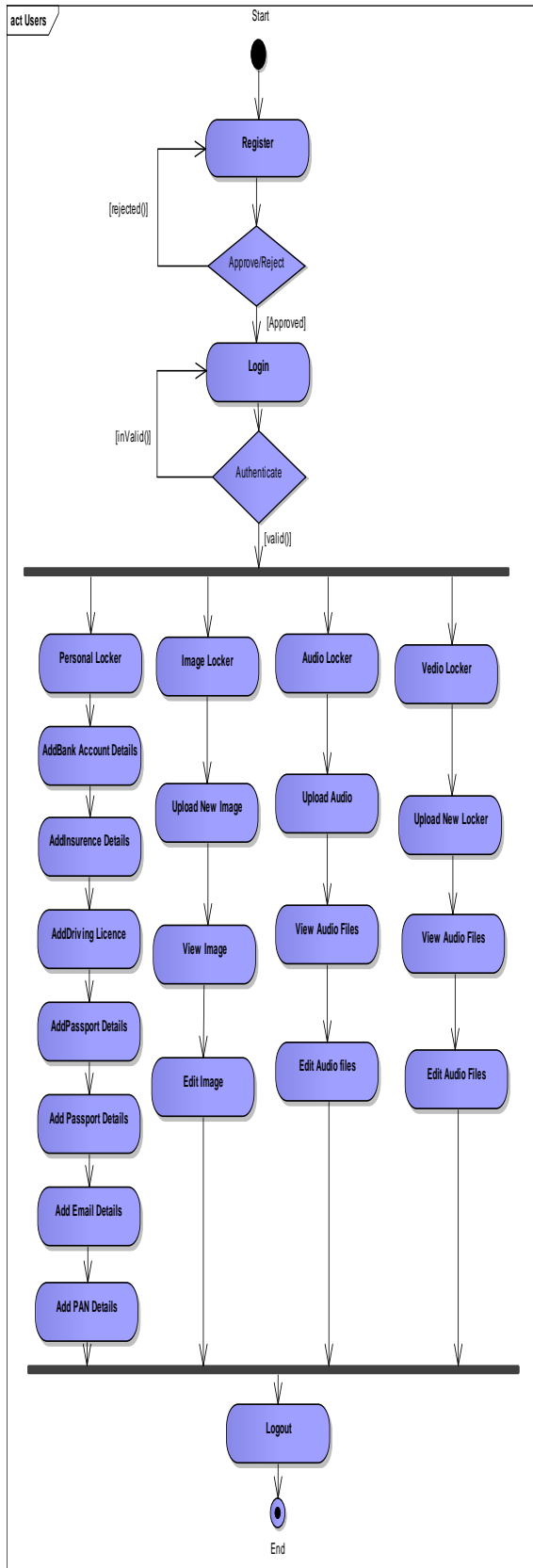
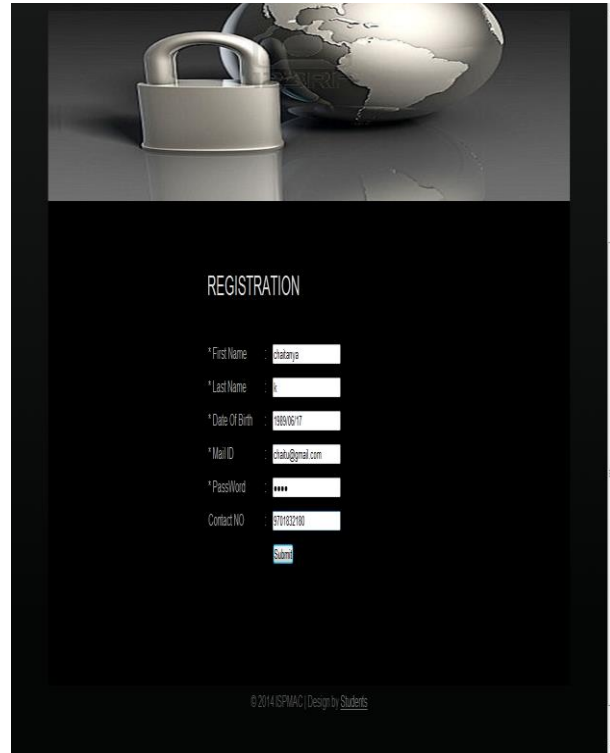

Fig: Activity Diagram for User



IV. SCREEN SHOTS

1. Registration page for Users



2.Login Screen for Users



3. User Status display page

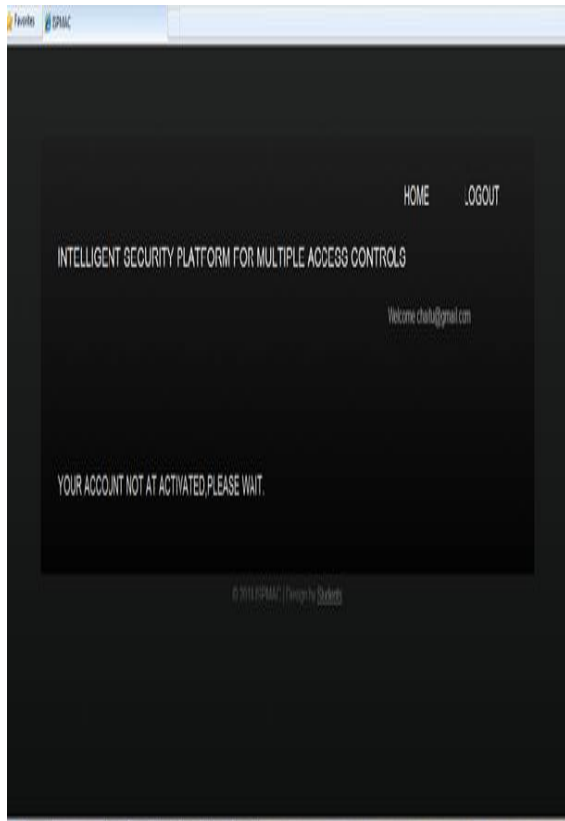

4. Admin login page

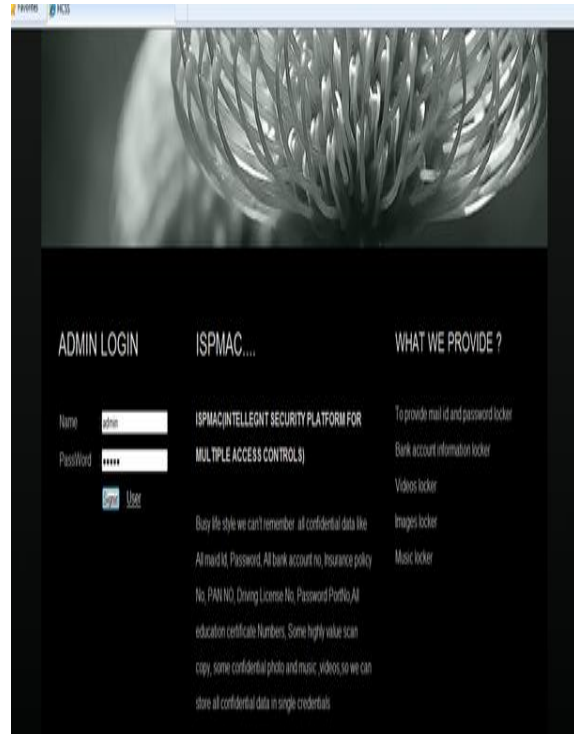

5. Admin home page



6. Admin public users accept/ reject page for newly registrations



7. User Status change like Lock and Unlock users at any time



9. User Login page

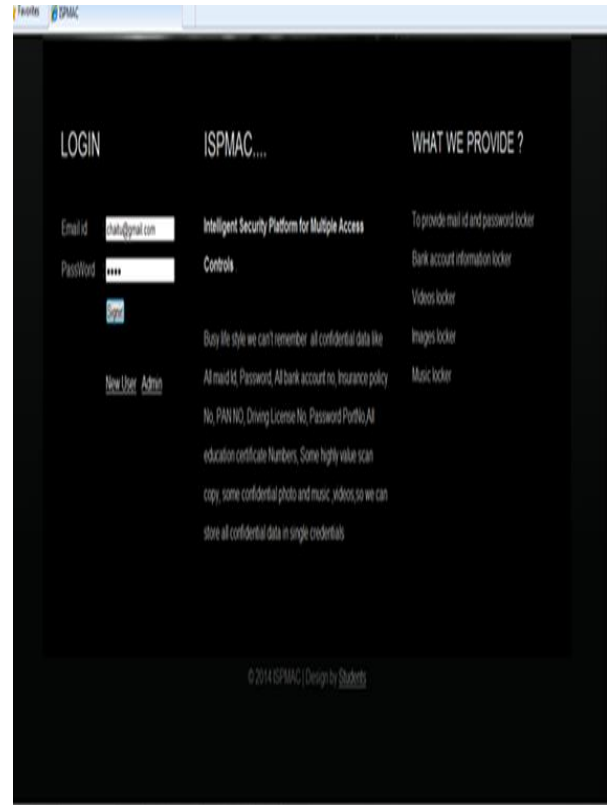

8. User Management view page for admin



10. User Home page



11. Personal & Bank locked page for User

BANK ACCOUNT    NEW ACCOUNT    EXISTED ACCOUNT DETAILS

INSURANCE POLICY    \*Acc Holder

Name

MAIL ID'S    \*Bank Name

\*Branch Name

PAN CARD    \*Acc Number

**Atm Card Details**

PASSPORT    Atm Card

Number(16)

DRIVING LICENCE    Digit(1)

Atm Cvd(3)

Digit(1)

13. User Email id locked page

BANK ACCOUNT    NEW ACCOUNT    EXISTED ACCOUNT INFO

INSURANCE POLICY    \*Account Name

\*User Name

MAIL ID'S    \*Password

PAN CARD

PASSPORT

DRIVING LICENCE

12. Insurance Policy page for User

BANK ACCOUNT    NEW POLICY    EXISTED POLICY INFO

INSURANCE POLICY    \*Policy Name

\*Policy ID

MAIL ID'S    \*Holder Name

PAN CARD    \*Policy Type

\*Amount

PASSPORT

DRIVING LICENCE

14. User PAN card locker page

BANK ACCOUNT    NEW ACCOUNT    EXISTED ACCOUNT INFO

INSURANCE POLICY    \*Holder Name

\*Pan Number

MAIL ID'S

PAN CARD

PASSPORT

DRIVING LICENCE



15. User Passport locker page

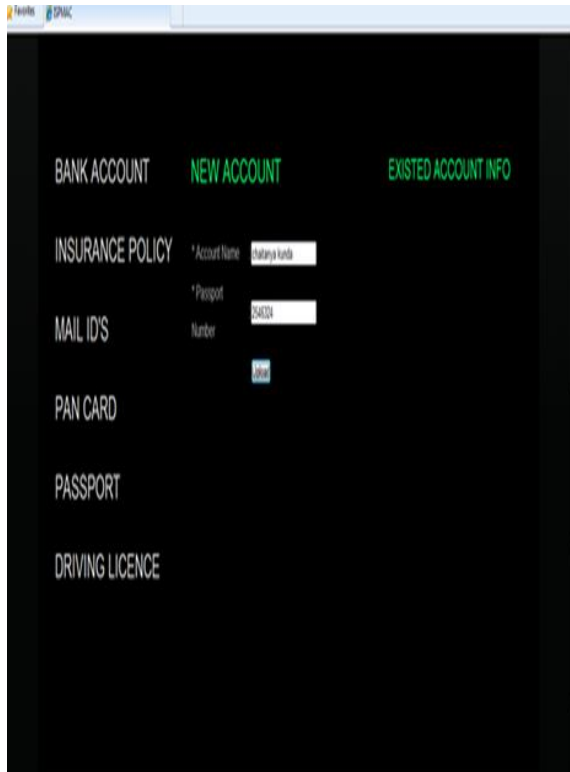

17. User Image locker page

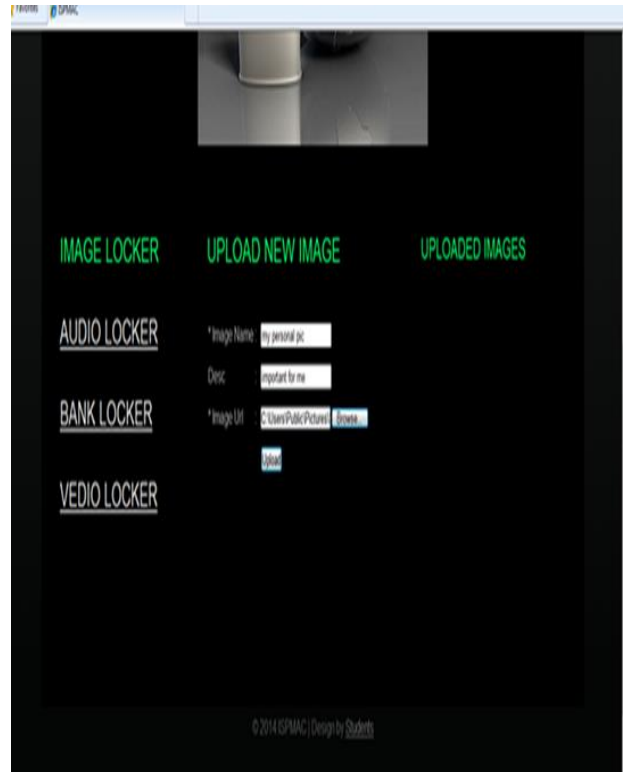

16. User Driving License locker page

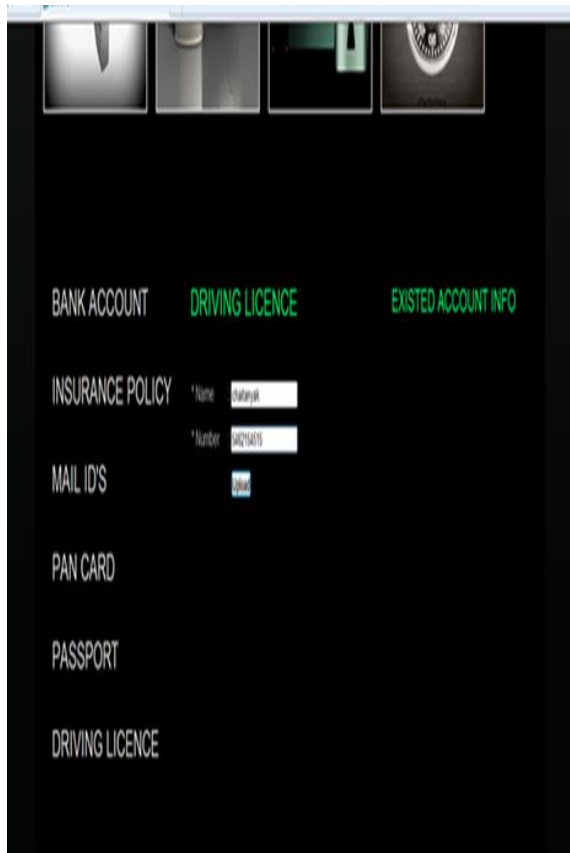

18. User Image view page





19. User Audio locker page

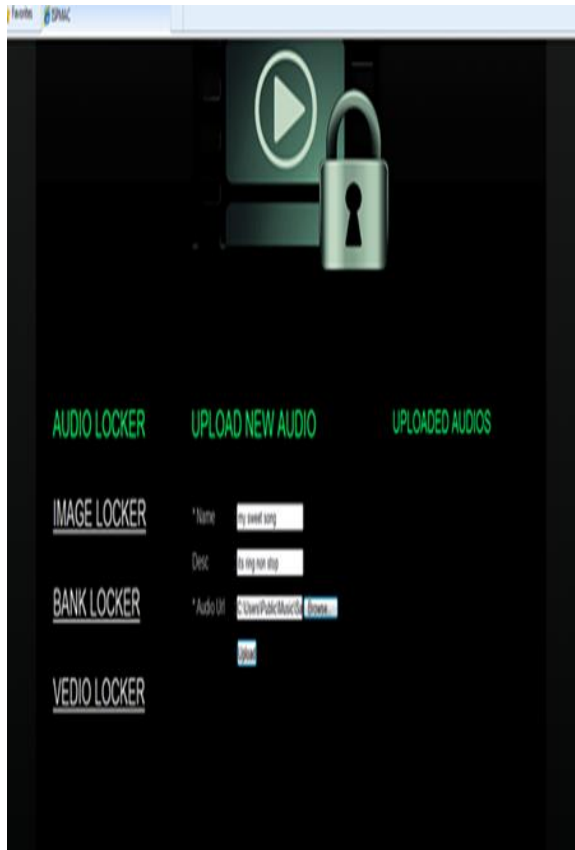

20. User Audio files view page



21. User Video locker page



## V. CONCLUSION

The “Intelligent Security Platform for Multiple Access Controls” is web-based applications. This application software has been computed successfully and was also tested successfully by taking “test cases”. It is user friendly, and has required options, which can be utilized by the user to perform the desired operations.

The software is developed using **Java** as front end and **My SQL** as back end in Windows environment.

The goals that are achieved by the software are:

- ✓ Instant access.
- ✓ Improved productivity.
- ✓ Optimum utilization of resources.
- ✓ Efficient management of records.
- ✓ Simplification of the operations.
- ✓ Less processing time and getting required information.
- ✓ User friendly.

## REFERENCES

- [1] M. Swetha, L. Haritha, “Review on cluster Key Agreement Protocol”, International Journal of Engineering analysis & Technology (IJERT), Vol. 1 Issue 10, December- 2012.
- [2] H. Guo, Y. S. Guo and Y. Chen, “The Implementation of Remote Meter Reading System Based on Linux and GPRS,” Application of Electronic Technique , Vol. 34, No. 11, 2008, pp. 82-84.
- [3] K. Al-Begain, I. Awan and D. D. Kouvatsos, “Analysis of GSM/GPRS Cell with Multiple Data Service Classes,”Wireless Personal ommunications, Vol. 25, No. 1, 2003, pp. 41-57
- [4] [www.javaworld.com](http://www.javaworld.com)
- [5] [www.apache.org](http://www.apache.org)
- [6] [www.java.sun.com](http://www.java.sun.com)
- [7] [www.w3schools.com](http://www.w3schools.com)
- [8] [www.itpapers.com](http://www.itpapers.com)