

A Design of Single Phase Ac-Dc Converter with Active Power Factor Correction Module

Ms. Poonam Verma¹, Mr. Arpan Dwivedi²

¹MTech Scholar, Power System, Shri Shankaracharya Insititute of Technology and Management (SSITM), Bhilai, CG, India

²Sr. Assistant Professor, Department of Electrical & Electronics Shri Shankaracharya Insititute of Technology and Management (SSITM), Bhilai, CG, India

Abstract- The evolution of growth in computers, laptops, uninterrupted power supplies, telecommunications and biomedical equipment has become overwhelming. Therefore, the use of such equipment results in a high power consumption and a small power density, which provided a large market for Distributed Power System (DPS). Conditioning of energy; In general, rectification is usually essential for electronic equipment. The rectifier behaves as a non-linear load that produces a non-sinusoidal line current due to the non-linear input characteristic. The constant growth of the use of electronic equipment has become a major problem according to the harmonic of the line current. Its adverse effects on the power system are recognized as healthy. Hence, in three-phase systems, the magnitude of the neutral current increases and becomes the cause of the overheating of transformers and induction motors, as well as the terrible conditions of the voltage waveforms of the system. There are a number of international standards to limit the harmonic content, caused due to the line currents of the equipment coupled to the electricity distribution networks. As a result, a reduction in line current harmonics, or Power factor correction - PFC is vital. This idea is the inspiration for this research effort. The objective is to improve the power factor almost with the minimum total harmonic distortion (THD).

linear loads causes the entire third harmonic to be exactly in phase and add it, instead of canceling it in all phases, therefore, current and heat develop in the neutral conductor. Harmonic loads reduce the distribution capacity and the effects on the quality of the power of public service systems. Computer equipment with switched power supplies, battery chargers, UPS, motors and variable speed drives, fax machines, laser printers, photocopiers, medical diagnostic equipment, etc. They function as non-linear loads, invariably.

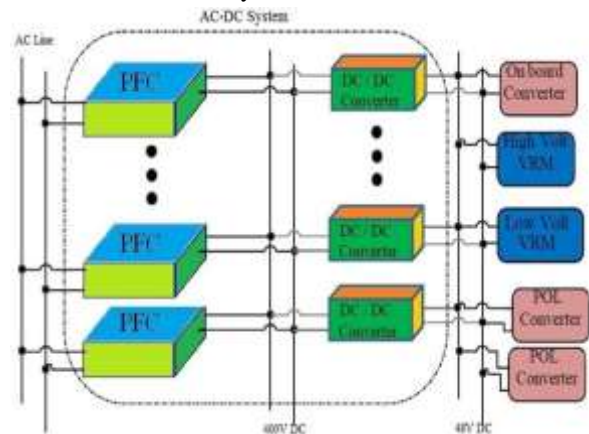

Fig. 1: Block Diagram of Basic Distributed Power

INTRODUCTION

The pulse sequence generates additional harmonic currents to the original current. In the sample, the third harmonic of 50Hz is 150Hz. For three-phase systems, even harmonics are canceled; therefore, the concern is the odd harmonics only. In a balanced distribution network, in the common neutral conductor, the current cancels each other when they add up and return to the source, due to which the neutral current becomes zero. The presence of non-

METHODOLOGY

Almost all electronic equipment has a different power rating and the amazing demands of power supplies for such equipment is a tense and very important task for the energy engineer. The AC-DC active PFC converter system introduces the idea of the regulated voltage of the DC bus. In the distribution and management of energy, this fulfils the greatest current desires and the dynamic characteristics of the AC-DC system. For specific applications such as

energy sources for telecommunications servers and computers, biomedical equipment and aeronautical engineering, it is very humiliating to consider high efficiency, high power density and rapid dynamic response, etc. But the transfer of electrical energy from the power grid to the final consumer is possible with low cost and high efficiency since Power Electronic Converter is designed with an appropriate and sophisticated control technique.

The magnetic components, which are used in the converters, are shrinking due to the high switching operations. This is reflected as advantages in cost, size and performance of power electronics and, therefore, is popularized in commercial, industrial, military, residential and aerospace environments today. In DPS, the implementation of galvanic isolation for protection and to achieve a flexible configuration of the system is very essential. By incorporating active PFC converters in DPS, the aforementioned perfection can be achieved. Research is still ongoing to achieve greater efficiency and a faster dynamic response and high-powered inflation with rigorous regulatory standards, which inspires to improve the performance of active PFC converters for DPS. With some techniques of control and simple elongated PWM technique are questioned in this thesis work. And for the improvement of the power factor and THD during the change of step in the load current and the line voltage, the research work is exploited in the PFC AC-DC converter.

POWER FACTOR CORRECTION

It is a measurement of the degree of the utilization of the power from grid. Mathematically it is the proportion of the real power to the apparent power and is in the range of 0 to 1.

$$PF = \frac{\text{Real Power}}{\text{Apparent Power}}$$

Real power is in watts and is the power necessary for real work done. Apparent power is in volt-amp. and is the vector summation of active and reactive power. For pure sinusoidal voltage and current waveforms; Where is the displacement factor of the voltage and current. In general PFC tends to the compensation of the displacement factor.

But for non-linear load i.e; for sinusoidal line voltage and non-sinusoidal line current waveform the PF

factor, represents the harmonic content of the current associated to the fundamental. Therefore in practical PF is proportional to both harmonic content & displacement factor. Where n is the nth order of the harmonic current.

The total harmonic distortion factor THD_i is defined as;

$$THD_i = \frac{\sqrt{I_{2,rms}^2 + I_{3,rms}^2 + \dots + I_{n,rms}^2}}{I_{1,rms}} = \frac{\sqrt{\sum_{n=2}^{\infty} I_{n,rms}^2}}{I_{1,rms}} \quad (1.5)$$

Hence, $K_p = \frac{1}{\sqrt{1+THD_i^2}}$ Load forecasting helps an electric usefulness to make important selection including selections on purchasing and generating electric load, load switching, and infrastructure development. The meaning of Load forecasting is to forecast the future demand with the help of historical load data available. Load forecasts are highly important for energy suppliers and other participator in electric energy generation, transmission, distribution and market. The accurate forecasting of the load is an essential element in power system.

Therefore, with a substantial harmonic content, a high power factor can be achieved. The power factor PF is not very influenced by harmonics, unless its amplitude is quite large (low, very large). Furthermore, a small harmonic content does not guarantee a high power factor (K_p near the unit, but low so).

Thus, in simple, the power factor correction is referred to as harmonic minimization of the line current. The main objective of the thesis is the correction of the power factor, that is; maintain a minimum phase angle between the input voltage and the current with an improved THD level, ie keep the harmonic content to a minimum. The effect of harmonics and their problems on the power supply system is considered significant and, therefore, the commissions and regulatory utilities of electricity worldwide are penalizing users for the harmonic discharge of power lines. The Central Indian Electricity Regulatory Commission has provided guidelines to the Institute of Electrical and Electronics Engineering (IEEE) Standard 519-92 on the permissible limits for harmonics in the electricity system. Both the utility and users must know and understand the specified standard and essential limits.

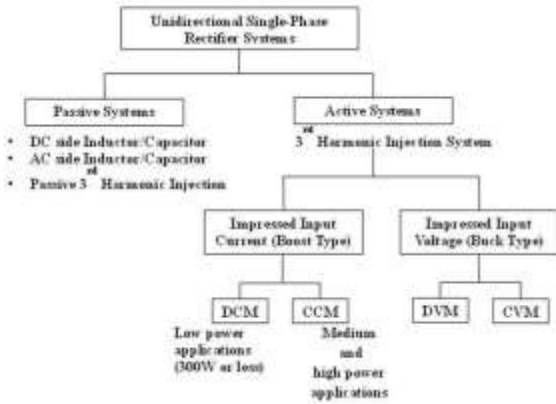

Fig. 1: Classification of PFC Method based on Mode of Switching

Advantages of the high power factor:

1. Voltage distortion is lower.
2. All power is active.
3. Small current RMS.
4. You can feed more charges.

Advantages of circuits with PFC:

The cost reduction factor, such as electrical charges (SMPS, electronic ballast or other electrical charges), becomes much simpler.

Because of the lower RMS current with PFC, it allows for using small and inexpensive network rectifiers for the electric charge manufacturer.

The input voltage for the DC electric load becomes stable and regulated

CONCLUSION

The minimization of line current harmonics is essential to comply with the standard that determines an increase in the degree of use of the power of the network. This is discussed as the PFC (Power Factor Correction) in general.

PFC is a technique to counteract unwanted effects of electrical loads that create a power factor (PF) of less than 1.

There are technical numbers for PFC. Based on the electrical selection element to filter the harmonics and obtain almost an input power factor, the PFC technique is classified in the "active" and "passive" PFC method.

The "passive PFC circuit" uses low-frequency filter components to reduce harmonics. Furthermore, in this technique the power factor cannot be significantly improved and the output voltage cannot

be controlled. The active switches are used in association with the reactive element for "active PFC approach" to improve the line current shape and to obtain a controllable output voltage. This DC-DC converter is used and is operated at high frequency to model the waveform of the most sinusoidal possible line current.

In the "Active PFC approach", the Boost PFC converter is acquired (as it has significant advantages) with an appropriate switching control strategy. There are various methods of control, including any method that can be used in the PFC application. In general, for any control strategy for PFC, two basic feedback compensation circuits are required. A voltage feedback compensation loop is used as an Outer Ring to maintain the bus voltage on a fixed DC value (default reference). An internal loop, known as current loop, is to control the current of the inductor at a specific level and to model the inductor current with the objective of being as similar as possible to the DC input voltage rectified by keeping almost the PF unit. PFC power supplies with control loop implementation are used to achieve a stable system with tolerable dynamic behaviour regardless of the system load conditions.

Using some conventional control methodologies and some non-linear control techniques, the non-sinusoidal input current is converted into sinusoidal with improved THD and their advantages and limitations based on constraints are discussed.

Some conventional control schemes are taken;

1. Peak current control
2. Control of the average current
3. PI control

Some non-linear control schemes are taken;

1. Control of dynamic evolution
2. Sliding mode control

The almost unit power factor with tolerated THD percentage of the input line current is observed for the Boost PFC converter operating in the control methods described above. Explains the power factor obtained and the THD for the Boost PFC converter with constant load R, which works with different control schemes. Considering that, for the PFC converter with controlled operation control in operating mode and sliding sliding controlled with

variable R-L-E-Load time, the power factor obtained and THD are analyzed.

FUTURE PURPOSE

For this work the Boost PFC converter with different controllers is realized with the help of MATLAB / Simulation, which can be analyzed in real time simulator for the consideration of practical applications. Furthermore, the hardware implementation can be implemented practically with a suitable control technique. Switching losses can be considered and a suitable soft switching technique can be introduced. It is possible to use a special optimization technique suitable to guarantee the very high dynamic stability and a very wide and stable operating range

REFERENCES

- [1] Ms. Kurma Sai Mallika, "Topological Issues in Single Phase Power Factor Correction", Thesis, Degree of Master of technology In Power control and drives, Department of electrical engineering National institute of technology Rourkela 769008, 2007
- [2] Matada Mahesh, "Performance improvement of ac-dc power factor correction converters for distributed power system", Thesis, Degree of Doctor of Philosophy Under the supervision of Prof. Anup Kumar Panda, NIT, Rourkela, Oct 2011
- [3] Yiqing Zhao, "single phase power factor correction circuit with wide output voltage range", Thesis, Degree of Master of Science, Electrical Engineering, Fred C. Lee, Chairman, Dusan Borojevic, Dan Y. Chen, February 6, 1998, Blacksburg, Virginia
- [4] M. Mankinkar, "Power supplies' energy business/ revenue models", in Proc. IEEE Applied Power Electron., Conf. (APEC'06), pp. 3-5, 2006
- [5] F. C. Lee, P. Barbosa, Peng xu, J. Zhang, B. Yang and F. Canales, "Topologies and design considerations for distributed power system applications", in Proc IEEE, vol. 89, no. 6, June 2001, pp. 939-950.
- [6] "Limits for harmonic current emissions (equipment input current <16A per phase). IEC 1000/3/2 International Standard. (1995).
- [7] "IEEE 519 Recommended Practices and Requirements for Harmonic Control in Electrical Power Systems. I IEEE Industry Applications Society/ Power Engineering Society. (1993).
- [8] "IEEE 519 Recommended Practices and Requirements for Harmonic Control in Electric Power Systems, I Tech. Rep., IEEE Industry Applications Soc./Power Engineering Soc., 1993.
- [9] N. Mohan, et al. Power Electronics: Converters, Applications, and Design. New York: NY, USA, John Wiley & Sons, Inc., 1995.
- [10] Kelley, Arthur W, et al. "Rectifier Design for Minimum Line Current Harmonics and Maximum Power Factor", IEEE Trans. on Power Electronics. vol. 7, no. 2, (Apr 1992): pp. 332-341.