

Review of Externally Fired Biomass Boiler: 100kgphr flow rate

Shubham Shivajirao Patil¹, Akash Azad Pawar², Vishwajeet Vijay Raorane³, Rushikesh Suresh Sapate⁴,
M. T. Sawant⁵

^{1,2,3,4} Students, Department of Mechanical Engineering, SSPM'S College of Engineering kanakavli, India

⁵ Professor, Department of Mechanical Engineering, SSPM'S College of Engineering kanakavli, India

Abstract- Harmonization of environmental protection and the growing energy needs of modern society promote the biomass application as a replacement for fossil fuels and a viable option to mitigate the greenhouse gas emissions. For domestic conditions this is particularly important as more than 60% of renewable belongs to biomass. Beside numerous benefits of using biomass for energy purposes, there are certain drawbacks, one of which is a possible high emission of NO_x during the combustion of these fuels. Thermal stresses in corrugated furnace tubes of different shape, i.e. with different corrugation pitch and depth, were analyzed first. It was demonstrated that the thermal stresses in corrugated furnace tube are significantly reduced with the increase of corrugation depth. Than deformations and stresses in the structure of a fire-tube boiler were analyzed in a real operating condition, for the cases of installed plain furnace tube and corrugated furnace tubes with different shapes. So if we place furnace outside the boiler then less thermal stress are acting on furnace because of furnace contact with atmospheric gasses. And also ash handling is easier in this case.

I. INTRODUCTION

A boiler is an enclosed system that is designed to provide means for combustion and transfers heat to water until it becomes hot water then steam. Under pressure, the steam is then used for transferring the heat to a process. The boiler system is made out of three different systems:

1. Feed Water System: this system is responsible for providing water to the boiler and regulating it automatically to meet the steam demand.
2. Steam system: this system is responsible for collecting and controlling the steam that is produced in the boiler.
3. Fuel system: the fuel system is the combination of equipment necessary for generating Heat.



Types of Boilers:

Boilers can be divided and classified into two large general categories; these two categories are fire tube boilers and water tube boilers:

Fire Tube Boilers: combustion gas passes through the inside of the tubes while the water is surrounding the outside of the tubes. Their advantages are its simplicity in order to construct it and less rigid water treatment requirements. Their disadvantages are the excessive weight-per-pound of steam generated and the excessive time required in order to raise steam pressure. Fire tube boiler is usually used in the facilities of heating applications.

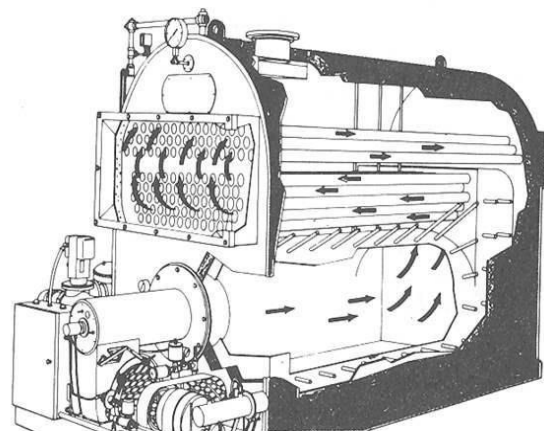

Water-tube Boilers: unlike Fire Tube Boilers, in the water tube boilers the water flows inside the tubes and combustion gas passes around the outside of the tubes. Their advantages are a lower unit weight-per-pound of steam generated and less time required to raise steam pressure; however, their disadvantages are High initial capital cost and their cleaning process. Water tube Boiler is used in facilities that use large steam.

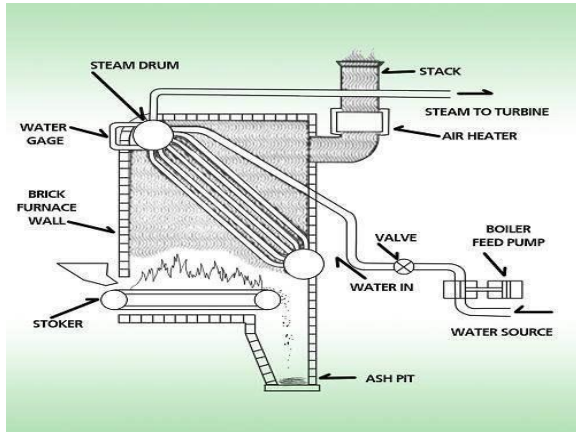

II. LITERATURE REVIEW

2.1 Thermal analysis

Research paper on Analysis of Boiler losses to improve Unit heat rate of coal fired thermal power plant.

The aim of monitoring boiler performance is to control the heat rate of plant. This paper deals with determination of operating efficiency of Boiler and calculates major losses for GSECL 210 MW unit in India

2.2 Biomass burner

MODERN BURNER FOR CENTRAL HEATING BOILER UTILIZING RENEWABLE ENERGY SOURCE – BIOMASS

To meet the technological requirements concerning the efficiency of using the energy of fuel in biomass furnaces and the profitability of implementing new solutions, it is necessary to continuously modify and optimize the existing biomass heating systems. Boiler designs with modern biomass-fueled burners should be characterized by high energy and environmental efficiency. The amount of the heat obtained indicates the efficiency of the burning process. The quality of

the burning process can be evaluated by means of the efficiency of the equipment that burns fuel.

2.3 Increasing efficiency of boiler

DESIGN OF THE HORIZONTAL FIRE TUBE BOILER FOR THE COMMERCIAL COOKING OF INDIAN FOOD Abhay Sharma, Prof. A.C. Tiwari Department of Mechanical Engineering, University Institute of Technology, RGPV, Bhopal, India

(a).High heat losses. (b).High fuel consumption. (c).High fuel cost. (d).Non uniform heating. (e).Pollution. (f).Bad effects on the health of the workers working around these systems.

III. BASIC PRINCIPLE

Externally fired boiler is a boiler whose furnace is neither wholly nor partly surrounded by water compared with internally fired boiler. In regular boiler there is problem of cleaning the furnace so we prefer externally fired boiler.

In regular boiler we generally use fossil fuel for boiler but they are costly so we use biomass as a fuel in our boiler. Biomass, the oldest form of renewable energy, has been used for thousands of years. However, with the emergence of fossil fuels, its relative share of use has declined in recent years. Currently some 13% of the world's primary energy supply is from biomass, though there are strong regional differences.

IV. WORKING

A boiler is an enclosed vessel that provides a means for combustion heat to be transferred into water until it becomes heated water or steam. The hot water or steam under pressure is then usable for transferring the heat to a process. Water is a useful and cheap medium for transferring heat to a process. When water is boiled into steam its volume increases about 1,600 times, producing a force that is almost as explosive as gunpowder. This causes the boiler to be extremely dangerous equipment that must be treated with utmost care.

The process of heating a liquid until it reaches its gaseous state is called evaporation. Heat is transferred from one body to another by means of radiation, which is the transfer of heat from a hot body to a cold body without a conveying medium,

convection, the transfer of heat by a conveying medium, such as air or water and conduction, transfer of heat by actual physical contact, molecule to molecule.

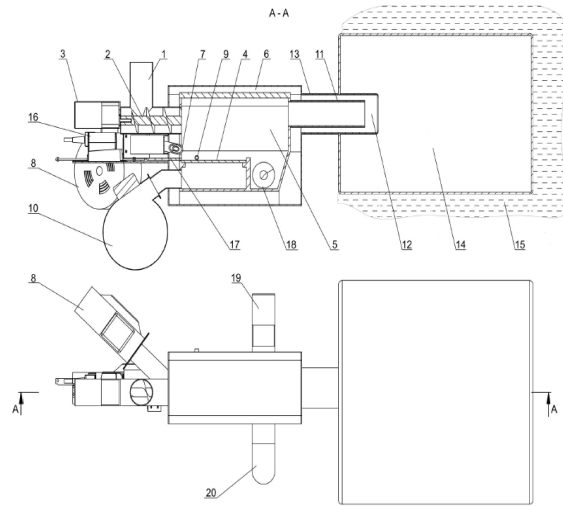

Fig. Basic elements of the designed burner for central heating boilers

Pelletized fuel in the form of biomass is fed to the burner via the fuel inlet (1). The worm screw Feeder (2) powered by the motor (3) transports the pelletized biomass onto the grate (4) located in the Gasifying chamber (5). The gasifying chamber (5) is found in the air chamber (6). The electrical heater (Igniter) (7) With the fan (8), which generates a hot air stream, is used to ignite fuel. The igniter (7) is Switched on and off automatically via a controller based on the signal from the flame sensor (9), which Detects the presence of flame or lack thereof in the gasifying chamber (5). The fan (10) draws air from the surroundings, stoking burning of the biomass through the holes found in the grate (4). The gases generated in the gasification process from the gasifying chamber (5) travel through the internal pipe (11) to the mixing chamber (12), where they are mixed with oxygen. Oxygen travels to the mixing chamber (12) along with the air blown in by the fan (8) via the external pipe (13). After combustion of the gaseous mixture in the mixing chamber (12) creates surplus of oxygen in the combustion chamber (14), which is found in the central heating boiler (15). The process of cleaning the grate (4), located in the gasifying chamber (5), is performed automatically at regular time intervals (cyclically) using the controller – drive element system, i.e. the Cleanout actuator (16) – cleaning element (17) – worm screw feeder of the ash remover

(18). The ash Remover worm screw feeder (18), driven by the motor (19), transports ash to the external ash pan (20)

V. ADVANTAGES

Do not require fossil fuels. Low fuel cost. Less installation cost. Complete combustion of fuel. Less maintainance. Works on biomass fuel.

VI. LIMITATIONS

Require more floor space. Uses only biomass fuel. More smoke.

REFERENCES

1. BOOKS:

Thermal and fluid power engineering by R.K.Rajpoot

2. RESEARCH PAPERS PUBLISHED IN JOURNALS:

- [1] MODERN BURNER FOR CENTRAL HEATING BOILERS
- [2] INFLUENCE OF FURNACE TUBE SHAPE ON THERMAL STRAIN OF FIRE-TUBE BOILERS
- [3] EFFICIENCY IMPROVEMENT OF BOILERS Sangeeth G.S.1, Praveen Marathur2
- [4] Fabrication of Pilot Multi-Tube Fire-Tube Boiler Designed For Teaching and Learning Purposes in Mechanical Laboratory Gbasouzor Austine Ikechukwu, Member IAENG
- [5] DESIGN OF THE HORIZONTAL FIRE TUBE BOILER FOR THE COMMERCIAL COOKING OF INDIAN FOOD Abhay Sharma, Prof. A.C. Tiwari

3 WEB SITE

1. www.google.com
2. www.Wikipedia.com