

# Analysis for DOA Estimation and Beam forming for Smart Antenna System

D. D. Khumane<sup>1</sup>, Dr. S. M. Jagade<sup>2</sup>

<sup>1</sup>*Department of Electronics and Telecommunication Engineering, S.T.B. College of Engineering, Tuljapur, India*

**Abstract-** This paper presents smart antenna using direction of arrival estimation and beam forming. Direction of arrival (DOA) estimation is based on the PM algorithm for identifying the directions of the desired signals and the null steering beam former adapts the antenna pattern to steer the main beam towards the desired user and nullify all other interference. This system can be used to reduce different drawbacks present in existed system like multipath and co-channel interference. These benefits include the enhancement of coverage and the channel capacity, lower transmitted power, better signal quality, higher data rate and providing value-added services such as user's position location (PL) and at the same time to minimize interference arising from other user by introducing nulls in their direction. Also this paper deals with adaptive beam forming approach for the dynamic case based on smart antennas and adaptive algorithms used to compute the complex weights like Least Mean Square (LMS) algorithm.

**Index Terms-** Smart Antenna Technology, Beam forming, Direction-of-Arrival (DOA) Estimation, Multiple Signal classification (MUSIC), PM (Propagator Method), Least Mean Square (LMS).

## I. INTRODUCTION

There is an ever increasing demand on mobile wireless operators to provide voice and high speed data services. At the same time, these operators want to support more users per base station to reduce overall network cost and make the services affordable to subscribers. As a result, wireless systems that enable higher data rates and higher capabilities are pressing need. Unfortunately because the available broadcast spectrum is limited, attempts to increase traffic within a fixed bandwidth create more interference in the system and degrade the signal quality. When omnidirectional antennas are used at the base station, the transmission and reception of

each users signal becomes a source of interference to other users located in the same cell, making the overall system interference limited.

The demand for wireless services has risen dramatically from few years. Wireless communication systems are evolving from the second generation systems to the third and fourth generation systems, which will provide high data rate multimedia services as video transmission. New value added services such as the position location (PL) services for emerging calls, the fraud detection, intelligent transportation systems, and so fourth are also coming in to reality[1,2,3].

The smart antenna systems can generally be classified as either switched beam or adaptive array systems. In a switched beam systems can generally be classified as either switched beam or adaptive array systems. In a switched beam system multiple fixed beams in predetermined directions are used to serve the users. in this approach the base station switches between several beams that gives the best performance as the mobile user moves through he cell. Adaptive beam forming uses antenna arrays backed by strong signal process capability to automatically change the beam pattern in accordance with the changing signal environment. It not only directs maximum radiation in the direction of the desired mobile user but also introduces nulls at interfering directions while tracking the desired mobile user at the same time. The adaptation achieved by multiplying the incoming signal with complex weights and then summing them together to obtain the desired radiation pattern. These weights are computed adaptively to adapt to the changes in the signal environment. The complex weight computation based on different criteria and incorporated in the signal processor in the form of software algorithms like Least Mean Square. [7]

A smart antenna technology can achieve a number of benefits like increase the system capacity, greatly reduce interference, increase power efficiency [4, 5]. In the following section we review on the smart antenna technology with the help of simulation by using MATLAB.

## II. BASICS OF DOA ESTIMATION & BEAMFORMING

Since most RF antennas amplifiers, mixers, filters and ADC technologies have reached a mature state, accurate estimation of the angle of arrival of signals impinging an array of antennas becomes the most important parameter regarding the performance of an adaptive array. Assuming a linear and isotropic transmission medium, multiple impinging wave fronts can be modeled as the superposition of these wave fronts impinging on the array. It is therefore necessary for the DOA estimation algorithm to be able to resolve impinging and often fully coherent wave fronts into their respective DOA's. Many DOA estimation algorithms exist, but only a few have found use in smart antennas i.e. conventional methods, linear prediction methods, Eigen structure methods and estimation of signal parameters via Rotational invariance techniques (ESPRIT) [6]. All these methods are based on the digital beam forming (DBF) antenna array. Signals received by individual antenna elements, are down converted to base band signal then they are digitized and fed into a digital signal processing (DSP) chip where the DOA estimation algorithm is executed. In this paper we take a brief review on the DOA estimation using PM algorithm for finding the PL and LMS algorithm uses the estimate of the gradient vector from the available data. LMS algorithm is important because of its simplicity and ease of the computation.

The delay and sum beam former is attractive because of its simplicity and ease of implementation. The limiting factor method is that though it can steer its main beam it has no control over its side lobes. The solution to this problem is the null steering beam former also minimize the signal to interference ratio. And for direction of arrival estimation (DOA) and beam forming would like to simulate Estimator and beam former as follows fig.1. for DOA estimation and beam forming

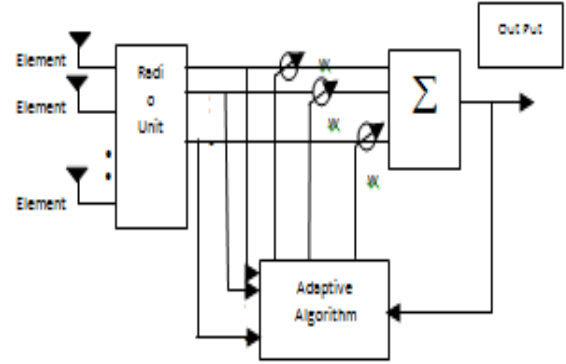

Fig. 1 Block Diagram for DOA Estimation & Beamforming For Smart antenna System

This method may be creates the radiation pattern of the antenna array in the desired direction and by nulling the pattern in the unwanted directions. This method in theory should minimize the signal to interference ratio.

## III. SIMULATION STUDY AND RESULTS

The simulation is developed in MATLAB the following parameters are used for the DOA estimation. First set the noise properties SNR antenna array spacing  $d$ ,  $M=6$  number of elements in antenna array,  $N=100$  number of times steps,  $dt$  and  $t$  are the length of time step and time vector. Then set the incoming signal properties,  $L=5$  for DOA and 1 For Beam forming number of incoming signals,  $f_0 = 1 \times 10^9$  incoming signal frequency, set amplitude and phase then round up the data noise. Calculate the matrix that content the antenna outputs

$$X(t) = A(\theta) * s(t) + n_x(t) \quad (1)$$

$$Y(t) = A(\theta) * \phi_1 * s(t) + n_y(t) \quad (2)$$

Where  $A$ =steering vector,  $s$ =signal received at first antenna,  $n_x(t)$   $n_y(t)$  are the additive white gaussian noise  $\phi_1$  is the diagonal matrix containing information about elevation angle for sub array  $x$  and  $y$ .

As shown in fig2 it is assumed that five coherent sources are received with desire angle at  $35^\circ$ ,  $75^\circ$ ,  $85^\circ$ ,  $105^\circ$   $138^\circ$  and SNR 20 dB and array spacing  $d=.5$  for all sources The attenuation coefficient of five coherent sources are 1, (.4+.7i), (-.5-.7i), (.5+.6i), (-.3+.8i) and unknown noise is in Complex symmetric Form Fig 2 Shows Power spectrum verses Desire angle plot

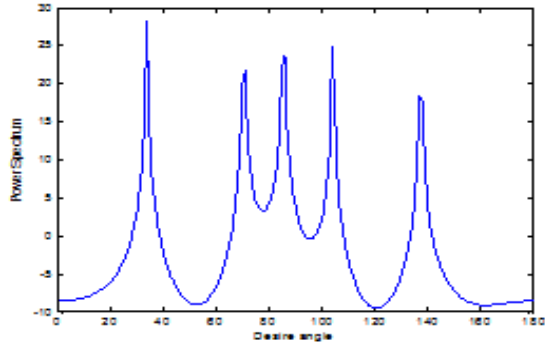

Fig. 2 Power Spectrum Of DOA Estimation at SNR=20dB and d=.5

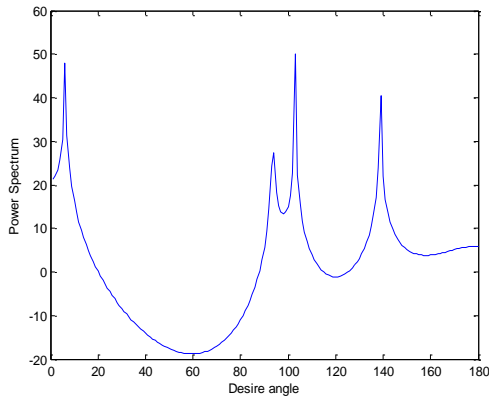

Fig. 3 Power Spectrum Of DOA Estimation at SNR=20dB and d=.4

As shown in fig3 when SNR=20dB and array spacing is 0.4M at that time only three signals are detected at angle  $85^{\circ}, 105^{\circ}, 138^{\circ}$  with variation of amplitude of spectrum is shown in fig.3 . Means signals are at angle  $35^{\circ}, 75^{\circ}$  are not detected

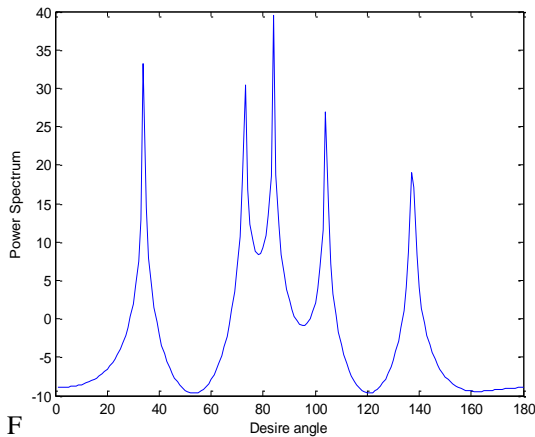

Fig. 4 Power Spectrum Of DOA Estimation at SNR=10dB and d=.5

As shown in Fig.4 it is assumed that five coherent sources are received with desire angle at  $35^{\circ}, 75^{\circ},$

$85^{\circ}, 105^{\circ}, 138^{\circ}$  and SNR 10 dB and array spacing  $d=0.5 M$  for all sources The attenuation coefficient of five coherent sources are  $1, (.4+.7i), (-.5-.7i), (.5+.6i), (-.3+.8i)$  and unknown noise is in Complex symmetric Form Fig 4 Shows Power spectrum verses Desire angle plot

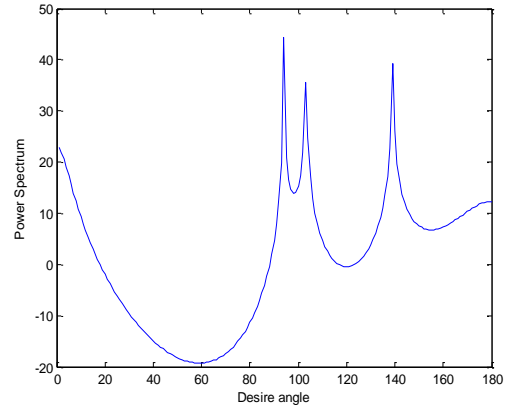

Fig. 5 Power Spectrum Of DOA Estimation at SNR=10dB and d=0.4M

As shown in fig5 when SNR=10dB and array spacing is 0.4M at that time only three signals are detected at angle  $85^{\circ}, 105^{\circ}, 138^{\circ}$  with variation of amplitude of spectrum is shown in fig.5 . Means signals are at angle  $35^{\circ}, 75^{\circ}$  are not detected

And for the beam formers simulation, set  $f_0$ , and  $d=0.5$  distance between antenna element,  $M=5$  number of array elements,  $L=1$  total number of users, set the additional variable like  $c$ - speed of light  $\lambda$ -wavelength,  $k$ -wave number, then generate the normalized array factor and plot the radiation pattern, and user position, in fig.4 where a side lobe allows the interfering signal although attenuated to reach the receiver after the weights are applied and the solution is null steering. Fig. 3, here the desired user at the 1000 and the respective NAF amplitude is shown here the user at 650, 350, 1250 & 1500 is the interferer.

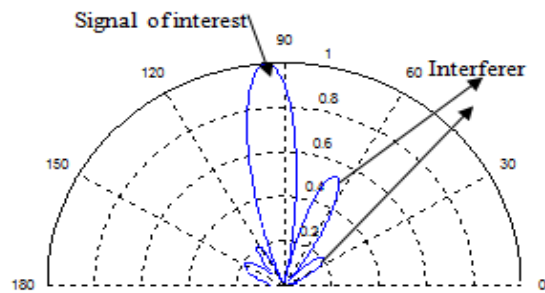

Fig. 3. Null steering beam former

#### IV. CONCLUSION

Here the simulation for the DOA estimation, compute a spatial spectrum then estimate DOA's. These methods apply weights to each element in the array so as to steer the antenna pattern towards a known look direction. Once a DOA is estimated, the beamformer adapts the antenna pattern to steer the main beam towards the desired user and place nulls in the unwanted direction.

It has advantage of analyzing the signals of arriving antenna array, using beams flexibly and optimistically reducing the probability of interfering and being interfered, enhancing frequency utilization efficiency, and improving system performance.

#### REFERENCES

- [1] T.S. Rappaport, J.H. Reed and B.D. Woerner, "Position location using Wireless Communications on highways of the future" IEEE communications Magazine, vol. 34, no.10, pp. 33-41, 1996.
- [2] G.V. Tsoulos, "Smart antennas for mobile communication systems: benefits and challenges," IEEE Electronic & Communication Engineering Journal, Vol 11, no.2 pp. 84-94, 1999.
- [3] K.J. Krizman, T.E. Biedka, and T.S. Rappaport, "Wireless position location: fundamentals, implementation strategies, and sources of error," Proc. IEEE Vehicular Technology Conference, Vol 12 pp. 919-923, Phoenix, Ariz, USA, MAY 1997.
- [4] Tsoulos G.V. Meach MA. Swalas S.C. Adaptive Antennas for Third Generation DS-CDMA Cellular Systems, Proceedings of the 45th Vehicular technology Conference, Vol1, pp 45-49, July 1995.
- [5] Okamoto G.T. Smart Antennas and Wireless LANS. Kluwer Academic Publishers, Norwell Mass., 2002
- [6] Godara, L.C., Application of Antenna Arrays to Mobile Communications, Part II: Beam forming and Direction-of Arrival Considerations, Proceedings of the IEEE, Vol. 85, No. 8 pp 1195-1245, August 1997.