

# Fire Accident Detection and Prevention in a Train Using GSM and GPS Based Alert

Shilpa G<sup>1</sup>, Leelankitha N<sup>2</sup>, Rahul Kumar<sup>3</sup>, Sheetal Sr<sup>4</sup>, Sreehari Sadasivan<sup>5</sup>  
1,2,3,4,5 *BMSIT Bangalore*

**Abstract-** The fire incidences in trains are among the most serious disasters to human lives and the property of Railways. Thus prevention of train fire has become a serious concern for Railways. There are many cases of fire consequences like damages to human lives and property in which many of them are of avoidable nature which can be eliminated by proper attention and awareness. Therefore, it becomes imperative that all required steps are taken to prevent and control fires has made efforts in this direction by incorporating information on probable causes, preventive measures during manufacturing and maintenance of Railway coaches.

This project is designed to demonstrate advance features which can be implemented in trains for Passenger safety and security. The purpose of our developed system is to minimize the effect of fire accident and also alerting the far-off property-proprietor accurately through sending Short Message (SMS) with live location by means of GSM (Global system for mobile) network and GPS (Global Positioning System). The prototype train model is equipped with few sensors. At critical condition or in case of emergency, Voice module will playback voice messages for Passengers alert. We will have proper controlling action to blow off fire. We can thus track live location from where the fire is being occurring.

**Index Terms-** Arduino, GSM, GPS

## I. INTRODUCTION

The fire incidences in trains are among the most serious disasters to human lives and the property of Indian Railway. The notices showing "Do not smoke", "Do not carry inflammable material" are the only precautionary warnings about the fire in each compartment .However, because of failure in routine maintenance system or by the activities of illegal social elements, the fire accidents in train occur frequently. Thus the prevention of train fire has become a serious concern for Railways. Fire on a

running train is more catastrophic than a static one, because the fanning effect may spread the fire very quickly to other coaches. Currently, Our Indian Railways doesn't use any sophisticated fire prevention methods. But it is realized to have an automatic system to monitor the fire in the coach giving alarm to the people, sending signal to the engine driver to stop the train and the fire is extinguished with the help of automatic sprinkler system. To have these all above in a single package a GSM AND GPS based alert system is proposed. This system is used for monitoring, automatic fire sprinkling, cautioning and preventing fire in running trains.

## II. LITERATURE REVIEW

Sumit Pandey et. al. [2] proposes an embedded system that will be used to alert people so that life as well as the damage can be minimized. If the train coach catches fire, the smoke sensor will sense it and send a signal to the microcontroller. The main focus of the paper is to apply the brakes to stop the train as soon as the fire is detected and send signals to driver and the guard so that they can take the necessary measures.

The author in [3] has proposed a system which is capable to detect fire and can provide the location of the affected region. Raspberry Pi 3 has been used to control multiple Arduino which are integrated with a couple of sensors and camera.

Ms. Gawande Pooja et.al [4] proposed system is using motion (accelerometer) and smoke/fire detection sensor based on IOT application integrated with android (GSM technology) to send information about train accident location to local citizens and administration using google map/GSM location system.

The system which is proposed in [5], uses the modern technology to detect the fire accidents and also to

inform the respective authorities immediately using GSM technology.

[6] Proposes on the system that will detect and control the fire accidents on running train. they are discussing about the fire accidents occurring in the train and data transfer to remote end using ZigBee Wireless Sensor Network. The engine driver will get the warning light and he stops the engine. Further he informs to the immediate concern authority for help.

### III. PROPOSED SYSTEM

In this project, when a fire occurs due to any reason, the fire can be detected by the fire sensor which is placed in each compartment. The fire detectors are placed in all the compartments in train to sense the fire. If the fire is in initial stage, the sensor senses the fire and gives an alarm. Hence the passenger, loco pilot can be alerted. Also the intimation about the accident will be sent through SMS to the control room. This SMS consists of the status of fire accident accurately by transmitting the physical parameters such as compartment number, intensity of fire with google map link.

This system is used for monitoring, automatic fire sprinkling, cautioning and preventing fire in running trains. This project is designed using Arduino mega (At mega 2560 microcontroller) platform. We are using flame sensor module to detect fire. Gas sensor monitors smoke. LM35 Temperature Sensor gives temperature in degree Celsius. APR9600 voice record/playback has stored voice messages. Water Sprinklers will get ON automatically. A 16x2 LCD displays status. GPS connects with satellite to give location details. GSM connects with mobile network to send SMS in Emergency situations.

#### SYSTEM DESIGN:

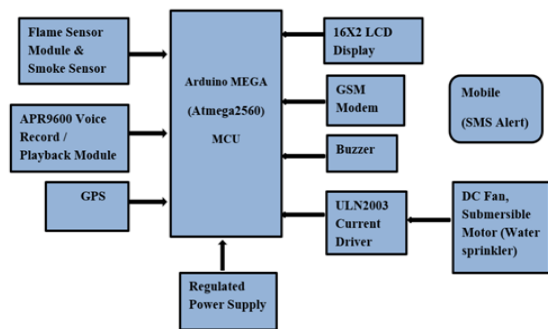

Fig: 1. Block Diagram

#### HARDWARE DESCRIPTION:

- Arduino MEGA (At mega 2560 Microcontroller)
- Regulated Power Supply
- GSM Modem
- GPS Module
- 16\*2 LCD Display
- Flame Sensor
- Gas Sensor MQ2
- APR9600 Voice Record / Playback Module
- Current Driver ULN2003
- 12V DC Fan
- 12V DC motor (Water sprinkler)

ARDUINO SOFTWARE IDE: Language used: Embedded C. The Arduino integrated development environment (IDE) is a cross-platform application that is written in the programming language Java. It originated from the IDE for the languages Processing and Wiring.

The Arduino IDE supports the languages C and C++ using special rules of code structuring. The Arduino IDE supplies a software library from the Wiring project, which provides many common input and output procedures. User-written code only requires two basic functions, for starting the sketch and the main program loop, that are compiled and linked with a program stub main() into an executable cyclic executive program with the GNU toolchain, also included with the IDE distribution. The Arduino IDE employs the program Arduino to convert the executable code into a text file in hexadecimal encoding that is loaded into the Arduino board by a loader program in the board's firmware.

#### PROTEUS ISIS SCHEMATIC SIMULATION SOFTWARE:

Proteus professional is a software combination of ISIS schematic capture program and ARES PCB layout program. This is a powerful and integrated development environment. Tools in this suit are very easy to use and these tools are very useful in education and professional PCB designing. As professional PCB designing software with integrated space-based auto router, it provides features such as fully featured schematic capture, highly configurable design rules, interactive SPICE circuit simulator, extensive support for power planes, industry standard CAD/CAM & ODB++ output and integrated 3D viewer.

ISIS has been created with this in mind. It has evolved over twelve years research and development and has been proven by thousands of users worldwide. The strength of its architecture has allowed us to integrate first conventional graph-based simulation and now – with PROTEUS VSM – interactive circuit simulation into the design environment. For the first time ever, it is possible to draw a complete circuit for a micro-controller-based system and then test it interactively, all from within the same piece of software. Meanwhile, ISIS retains a host of features aimed at the PCB designer, so that the same design can be exported for production with ARES or other PCB layout software.

#### IV. ARDUINO MEGA (AT MEGA 2560 MICROCONTROLLER)

The Arduino Mega 2560 is a microcontroller board based on the ATmega2560. It has 54 digital input/output pins (of which 15 can be used as PWM outputs), 16 analogue inputs, 4 UARTs (hardware serial ports), a 16 MHz crystal Oscillator, a USB connection, a power jack, an ICSP header, and a reset button. It contains everything needed to support the microcontroller; simply connect it to a computer with a USB cable or power it with a AC-to-DC adapter or battery to get started.

The Mega 2560 is an update to the Arduino Mega, which it replaces. The Mega2560 differs from all preceding boards in that it does not use the FTDI USB-to-serial driver chip. Instead, it features the ATmega16U2 (ATmega8U2 in the revision 1 and revision 2 boards) programmed as a USB-to-serial converter

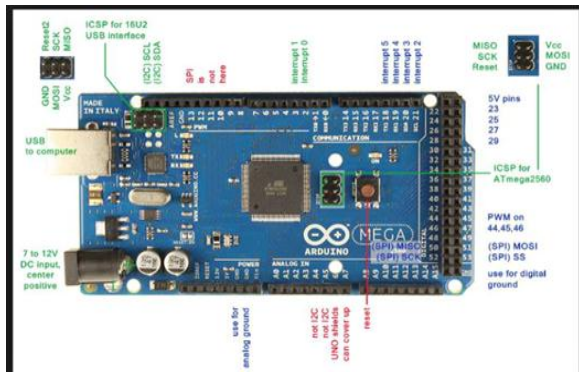

Fig: 2 Arduino mega pin diagram

#### V. REGULATED POWER SUPPLY

This is most common voltage regulator that is still used in embedded designs. LM7805 voltage regulator is a linear regulator. With proper heat sink these LM78xx types can handle even more than 1A current. They also have Thermal overload protection, Short circuit protection. This will connect at the output of rectifier to get constant Dc supply instead of ripple voltages. It mainly consists of 3 pins:

1. Input voltage
2. Output voltage
3. Ground

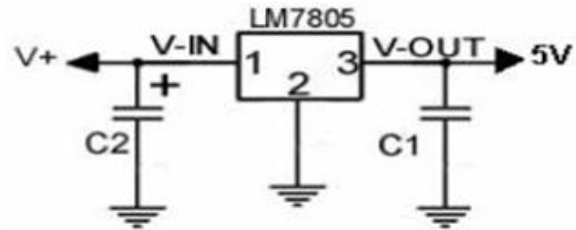

Fig: 3 Circuit Diagram of Regulated Power Supply

#### VI. GSM MODEM

GSM modem is a specialized type of modem which accepts a SIM card, and operates over a subscription to a mobile operator, just like a mobile phone. From the mobile operator perspective, a GSM modem looks just like a mobile phone. When a GSM modem is connected to a computer, this allows the computer to use the GSM modem to communicate over the mobile network. While these GSM modems are most frequently used to provide mobile internet connectivity, many of them can also be used for sending and receiving SMS and MMS messages. A GSM modem can be a dedicated modem device with a serial, USB or Bluetooth connection, or it can be a mobile phone that provides GSM modem capabilities.



Fig: 4 Gsm modem

#### VII. GPS MODULE

Global Positioning System commonly referred to as GPS is a network of satellites that continuously transmit coded information, which makes it possible to precisely identify locations on earth by measuring distance from satellites. The satellites transmit very low power radio signals allowing anyone with a GPS receiver to determine their location on earth. This communication system consists of 3 segments namely Space segment (the satellites), a Control segment (the ground stations), and a User segment (GPS receiver and its user).



Fig: 5 GPS module

VIII. 16\*2 LCD DISPLAY

A liquid crystal display (LCD) is a thin, flat display device made up of any number of colour or monochrome pixels arrayed in front of a light source or reflector. Each pixel consists of a column of liquid crystal molecules suspended between two transparent electrodes, and two polarizing filters, the axes of polarity of which are perpendicular to each other. Without the liquid crystals between them, light passing through one would be blocked by the other. The liquid crystal twists the polarization of light entering one filter to allow it to pass through the other.

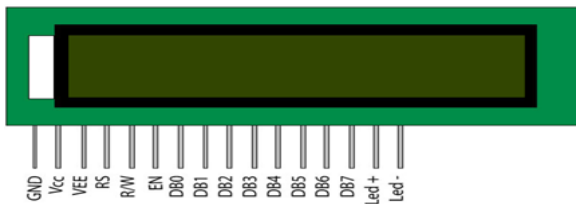

Fig: 6 LCD pin diagram

IX. FLAME SENSOR

The flame sensor is used to detect the fire or other light sources which are in the range of wavelength

from 760nm to 1100nm. The module consists of an IR sensor, potentiometer, OP-Amp circuitry and a led indicator. When a flame will be detected, the module will turn on its red led. This module is sensitive to flame but it can also detect ordinary light. The detection point is 60 degrees. The sensitivity of this sensor is adjustable and it also has a stable performance.



Fig: 7 Flame sensor

X. GAS SENSOR MQ2

Sensitive material of MQ-2 gas sensor is SnO<sub>2</sub>, which with lower conductivity in clean air. When the target combustible gas exists, the sensors conductivity is higher along with the gas concentration rising. Please use simple electro circuit, convert change of conductivity to correspond output signal of gas concentration. MQ-2 gas sensor has high sensitivity to Methane, Propane and Butane, and could be used to detect both Methane and Propane. The sensor could be used to detect different combustible gas especially Methane, it is with low cost and suitable for different application.



Fig: 8 Gas Sensor module

XI. APR9600 VOICE RECORD /PLAYBACK MODULE

There are various types of voice processing chip (IC) with various features for speech compression and processing is readily available. Here is projects called Voice recording and play back using chip

(APR9600). An APR9600 is a single chip voice recorder and playback device from A plus integrated circuits. This chip used flash non-volatile memory to store up to 256 voltage levels. i.e. for 32 to 60 seconds.



Fig: 9 APR9600 voice module

This chip have many features like, one can select sample rates with consequent quality and recording times. Microphone amplifier, automatic gain control (AGC) circuit, intends anti-aliasing filter, integrated output amplifier and measure management.

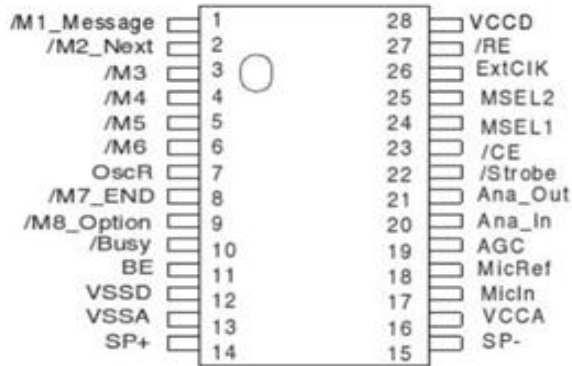

Fig: 10 pin diagram of APR9600 voice module

XII. CURRENT DRIVER ULN2003

It is a linear monolithic IC, which is used to drive the stepper motors, relays, lamps etc. Normally the output current from the micro controller is of 30mA. So by using this IC i.e. ULN2003 we can boost the current signal up to 600mA. So this IC generates required voltages.



Fig: 11 Pin Diagram of ULN2003

XII. 12V DC FAN

This fan is 12V operated fan. Uncontrolled heat generated by electronic devices will not only decrease the performance of any system, but will ultimately lead to complete system failure. In order to prevent this catastrophe from occurring, it is imperative that your equipment be designed with an efficient cooling system in mind. This system will not only be crucial to heat dissipation but will also contribute to the stability and long life of the equipment itself.



Fig: 12 12V Dc fan

XII. 12V DC MOTOR (WATER SPRINKLER)

This is a low cost, small size Submersible Pump Motor which can be operated from a 2.5 ~ 6V power supply. It can take up to 120 litres per hour with very low current consumption of 220mA. Just connect tube pipe to the motor outlet, submerge it in water and power it. Make sure that the water level is always higher than the motor. Dry run may damage the motor due to heating and it will also produce noise.



Fig: 13 Water sprinkler

XIII. WORKING

This is Embedded system-based project which is designed for fire accident detection and prevention using GSM and GPS technology. Gsm getting signal

through on mobile tower, GPS through satellite signal and regulated supply of 5V and 12V are connected to Arduino. 12V is given to ULN current driver for both Dc motor rotation and Dc fan as it requires more voltage. 5V is given to all the sensors, GSM, GPS, voice module and LCD display.

PCB is designed on Arduino board as it reduces the complexity of connections. and all the components are connected to Arduino through the PCB.

Firstly, the program should be loaded to Arduino and when supply is given, the system will start working. Once Fire is sensed by the fire sensor and it gives signal to the Arduino then Arduino activates the GSM modem and GPS. GSM sends the message of fire alert and live location with map link by using GPS module to the respective authorities and control room at the same time water sprinkler is activated to reduce the amount of fire where as in case of smoke detection exhaust fan is activated to reduce the smoke.



Fig: 14. Working of the proposed system

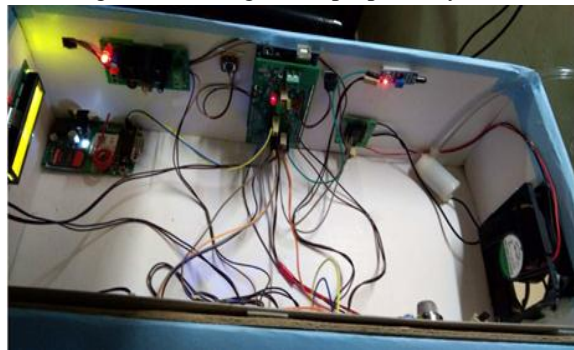

Fig: 15. Final assembly of the project

#### XIV. RESULT

This system is tested on the GPS & GSM technology with desired results. This system is easy to use and simple in its operation. The model can be installed

with economical cost. The GSM technology gives fast response of sending message to authorized person mobile. SMS received basically depends on the signal strength range that you have. We have developed and tested the prototype model using embedded CPP language using Arduino platform. We are having GPS google map link in SMS so that authorized user can directly get location information with the help of internet. We are having controlling actions to blow off fire or smoke with the help of exhaust fan and water sprinklers. Audio alert helps others to know critical condition so that they can take necessary actions.

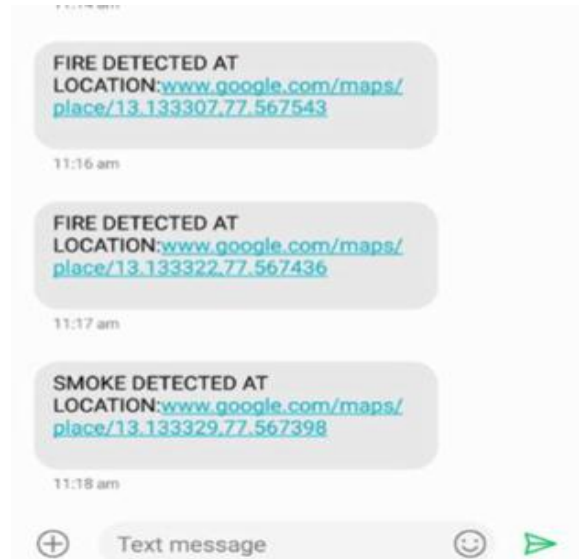

Fig 16. Message sent to the given mobile number with map link

#### XV. CONCLUSION

This working system is based on microcontrollers. This system will be very much useful for reducing the accident by detecting fire at initial stage itself, alerting the passengers, passing the message to the loco pilot, authority and nearest fire department with the help of GSM and GPS module. Hence the system is much secured. With the installation of fire extinguisher system, there will be the implementation of pre- action system, which will make the journey hazardous free, because sometimes, when the fire occurs, due to panic or due to lack of knowledge, people are not able to use the extinguishers properly, which cause accidents. Hence, proper safety system is to be provided to give complete protection. Fire resistant materials should be used to avoid fire in

trains and evacuation from the emergency window should be refurbished. The sprinklers will be connected through flexible pipes which are made up of Copper tubes, which will be heat resistant.

#### REFERENCES

- [1] [https://cag.gov.in/sites/default/files/audit\\_report\\_files/Union\\_Performance\\_Railway\\_29\\_2015\\_chap\\_1.pdf](https://cag.gov.in/sites/default/files/audit_report_files/Union_Performance_Railway_29_2015_chap_1.pdf)
- [2] Sumit Pandey, Abhishek Mishra, Pankaj Gaur, Amrindra Pal, Sandeep Sharma: "Automatic Fire Initiated Braking and Alert System for Trains": Department of Applied Electronics and Instrumentation DIT University Dehradun: 248009, India; 978-1-4799-1734-1/15 \$31.00 © 2015 IEEE, DOI 10.1109/ICACCE.2015.85
- [3] Ahmed Imteaj, Tanveer Rahman, Muhammad Kamrul Hossain, Mohammed Shamsul Alam and Saad Ahmad Rahat: "An IoT based Fire Alarming and Authentication System for Workhouse using Raspberry Pi": Department of Computer Science and Engineering, International Islamic University Chittagong, Bangladesh; February 16-18, 2017, Cox's Bazar, Bangladesh.
- [4] Ms. Gawande Pooja, Mr. Sonawane Kishor: "IoT Based Railway Disaster Management System": 15-16 Feb. 2018, DOI: 10.1109/ICCMC.2018.8487802, Publisher: IEEE
- [5] M. Nagamani, B.V.Siva Prasad, M. Suresh, P.Ramya Sree, G. Sumanth: "Fire Accident Avoidance System in Trains Using Gsm Technology": Dept. SRK Institute of Technology; IOSR Journal of Electronics and Communication Engineering (IOSR-JECE) e-ISSN: 2278-2834, ISSN: 22788735. Volume9, Issue4, Ver.III (Jul-Aug.2014)
- [6] R. Pitchai Ramasamy, M. Praveen Kumar, S. Sarath Kumar and R. Raghu Raman: "Avoidance of Fire Accident on Running Train Using ZigBee Wireless Sensor Network": Information Technology, Adhiparasakthi Engineering College Melmaruvathur, International Journal of Information and Computation Technology. ISSN 0974-2239 Volume 3, Number 6 (2013).
1. Shilpa G, has completed his Master in Technology in the Department of Electrical Engineering. At present he is working as Assistant professor in the Department of Electrical and Electronics Engineering at BMSIT Bengaluru.
2. Leelankitha N, at present she is studying in the final year in the Department of Electrical and Electronics Engineering at BMSIT Bengaluru.
3. Rahul Kumar, at present he is studying in the final year in the Department of Electrical and Electronics Engineering at BMSIT Bengaluru.
4. Sheetal SR, at present she is studying in the final year in the Department of Electrical and Electronics Engineering at BMSIT Bengaluru.
5. Sreehari Sadasivan, at present he is studying in the final year in the Department of Electrical and Electronics Engineering at BMSIT Bengaluru.

About the Authors