

Soft Starting of Three Phase Induction Motor

Akhil T S¹, Geordy Cleetus Koyikkara², Navaneeth P R³, VenkideshwaraPrasad P D⁴, Ms. Merry Mathew⁵

^{1,2,3,4,5} *Electrical and Electronics Engineering Dept., A P J Abdul Kalam Technological University, Kerala, India*

Abstract- The project is designed to provide low voltage start to induction motors. This is achieved by using star to delta conversion. Star/Delta starters are probably the most common reduced voltage starters in the 50Hz industrial motor world. Star delta is used in an attempt to reduce the start current applied to the motor. Thereafter, full load current is applied to the motor.

The Star/Delta starter is generally manufactured from three contactors; and electromechanical timer and a thermal overload for operating a 3 phase motor at 440 volt at ac mains supply 50 Hz. The interlocking arrangement of all the contactor coils is traditionally wired in 440 volt AC.

This project uses a system to start a 3 phase motor at 440 volt AC mains supply 50 Hz with a set of 12 volt DC relays in star mode first and then to delta mode by an electronically adjustable timer. A set of relays are used to shift the motor connections from star to delta with a time delay.

The project is supplied with six lamps instead of a 3 phase motor i.e., two lamps representing each phase winding of the motor. The interlocking arrangement of the relay coils and the electronic timer are all wired in low voltage DC of 12 volt fed from an inbuilt DC power supply for safe handling of the starter during the study. It still retains its application for a 3 phase motor starting with single phasing prevention also.

During star operation the lamps would glow dim indicating the supply voltage across the coils are $440/\sqrt{3}$. In delta condition after the timer operates the lamps would glow with full intensity indicating full supply voltage of 440volts. The timer comprises of a 555 in mono-stable mode the output of which is fed to a relay for changing the mains supply from 3 phase star to delta.

The project also has the provision of single phasing protection since 3 phase motors get burnt if any one phase goes missing during running. The output to the lamps shall be completely cut-off in the event of any phase failure.

Further the project can be enhanced by using a thyristors in firing angle control principle for soft start of the induction motor that would overcome all the drawbacks of star delta starter.

Index Terms- Di/dt, Silicon Controlled Rectifier (SCR), soft starter, switching transients

I. INTRODUCTION

Starting of induction motors creates many challenging problems to the motor, and to the power supply system. Because of significantly higher starting current than the rated current, starting of induction motors is a process that can damage, and influence characteristics and performances of the motor and electrical power systems. High voltage fluctuations, dips and sags, can occur in electrical power system associated with the starting of the motor. A soft-starter is a solid-state electronic device that shapes the supply voltage prior to connection to the motor terminals. A soft starter is a relatively new device and is used for smooth start of induction motors, particularly medium voltage motors, and adds flexibility in the operation and the interoperability. Different methods have been developed to address particular induction motor starting problems associated with motor size and the stability of the connected network.

The standard soft-starter consists of thyristors or SCRs that shape the source signal controlling the thyristors firing angles. The soft-starter can be based on controlling different starting characteristics, including current, torque, and voltage, and can be easily adjusted based on the different loadings.

It can consist of mechanical or electrical devices, or a combination of both. Mechanical soft starters include clutches and several types of couplings using a fluid, magnetic forces, or steel shot to transmit torque, similar to other forms of torque limiter. Electrical soft starters can be any control system that reduces the torque by temporarily reducing the voltage or current input, or a device that temporarily alters how the motor is connected in the electric circuit.

II. CIRCUIT DIAGRAM

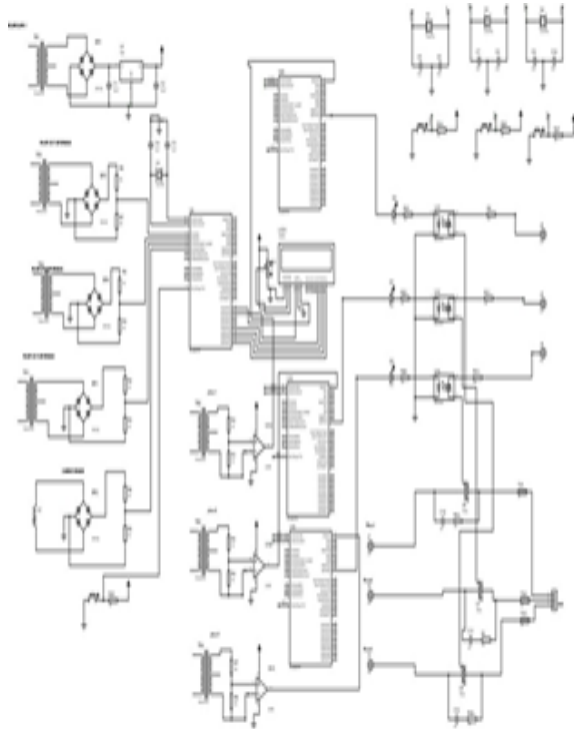

Fig. 1 Circuit Diagram

The basic circuit of the microcontroller consists of a power supply unit, External Crystal oscillator and a reset circuitry. The power supply consist of a voltage regulator which is used to regulate the voltage to a fixed voltage of 5v .Normally 7805 voltage regulators are used for this purpose.

Normally the crystal oscillators provided with the microcontrollers are of 16MHz and to 22pf capacitors are used with the microcontroller as decoupling capacitors for decreasing the noise.

The reset circuitry used here consist of a switch and a resistor normally a HIGH signal is present in the mCLR pin of the microcontroller when the switch is pressed a LOW presents at the pin and microcontroller gets reset and as there is a resistor provided in circuit the Vcc and Ground never get direct short while resetting.

The microcontroller consists of an internal ADC module this ADC module is used to convert the ADC reading from the sensor to a digital value. The ADC provided with microcontroller is of 10 bit resolution, which reads value from 0-1023. The Devices which output the analog variation can communicate with controller using this module.

The LCD is an external module used to display the details to the user. The LCD communicates with the microcontroller using parallel communication of the data. The data lines are connected to a port of the microcontroller. The relays with lamp load are connected in star configuration and after defined time interval relay are triggered and changed to delta configuration.

III. POWER SUPPLY

The 12V AC input from the transformer is rather high. The rectifier + smoothing capacitor will level the voltage at the peak value; $2\sqrt{2} \cdot V_{RMS}$, though you have to subtract 2 diode drops from the rectifier, about 1V per diode. So $V_{IN} = 2\sqrt{2} \cdot 12V - 2 \cdot 1V = 15$

The 7805 can supply up to 1A, and then the dissipated power is

$$P_{REG} = (V_{IN} - V_{OUT}) \cdot I = (15V - 5V) \cdot 1A = 10W$$

Try to keep the dissipation low by having a lower input voltage. This should be at least 8V, and then an 8V transformer should be fine. At 1A you'd still need a heat sink.

The smoothing capacitor's value depends on the load. Every half cycle of the mains voltage the capacitor will be charged to the peak value and start to discharge until the voltage is high enough to charge again. A simplified calculation gives

$$C = I \cdot \Delta T \Delta V$$

Where ΔT is half the mains cycle (e.g. 10ms in Europe, 8.33ms in the US). This formula assumes a linear discharge, which in reality often will be exponential, and also assumes a too long time, which often will be 70-80% of the given value. So, all in all, this is really worst case. Based on the above equation we can calculate the ripple voltage for a given current, like 100mA:

$$\Delta V = I \cdot \Delta T / C = 100mA \cdot 10ms / 470\mu F = 2.1V$$

which is OK given the high input voltage. In practice the ripple will probably be around 1.6V. A 1A current, however, would cause a 16V ripple, so you should use at least a 4700Mf capacitor. Ripple is the variation in voltage which remains after smoothing with the capacitor. No matter how big your capacitor is you'll always have a certain amount of ripple, though with large capacitors and low power consumption you can reduce it to mV levels.

The part used in our circuit is the 7805; however different models exist that limit the output-voltage to

other levels. Helpfully, they are labeled accordingly. A 7812 will limit the output to 12Volt, etc.

Many manufacturers produce parts with the 78xx name on it; not all start with 'LM' before it, yet all seem to have grossly the same operating specs, as well as the same pin out.

One thing that all the 'normal' versions of this circuit have in common is that they all require at least (about) 1.5V over-voltage to function. What this means is that you can only get 5Volt out if you put at least 6.5Volt in. It would be good to never cut it that close, either, and always provide some extra voltage just in case there are fluctuations on the input voltage.

There are however 'low-drop' versions available are a little higher cost that require less over-voltage; some as low as 0.3V. All of these parts are able to provide up to 1Amp of output-current. It is good to realize that they only succeed in handling that current if you make sure they can keep cool properly. Remember they 'burn' all the excess energy into warmth and thus risk overheating if not provided with a heat sink of some kind. Simply screwing a sheet of metal to the back will help enough. Without a heat sink, drawing more than 500mA from them will result in trouble.

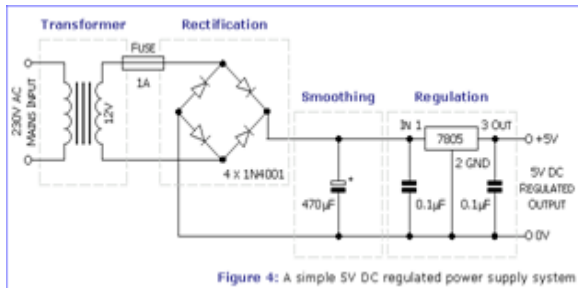

Figure 4: A simple 5V DC regulated power supply system

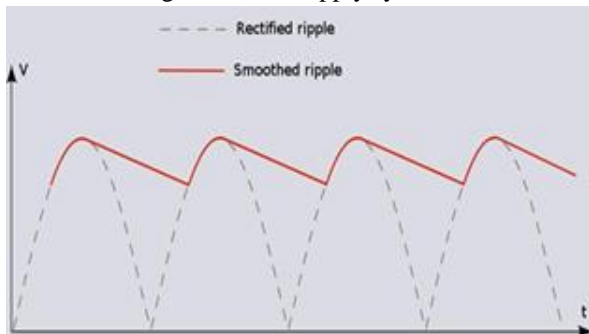

Fig 3. Rectified output

A. The Recommended power supply design

It is recommended to use power supply based on 7800 series regulator for small microcontroller based

project. 7805 regulator is widely used cheap and reliable solution which will output regulated +5V on its O/P terminal. A good power source would be 12V 500mA power pack which is powered by mains power outlet.

The regulator should not be too much larger than actual expected current demand of project. When estimating power, calculate as 5mA for MCU chip, about 3mA for TTL/CMOS ICs, 10mA for regular size LED etc. Always refer datasheets of your parts to find out their operating standard and peak currents and make power supply rated to peak operating current of project. For a load of 50mA or less use a 78L05 which is rated at 100mA but will deliver a bit more. If you need more than 50mA for your circuit, 7805 regulator can supply about 1A with heat sink on it.

Having series diode in the +ve line before the input capacitor is good idea because this protects power supply when the power-pack is connected the wrong way (it happens quite often during experiments). The input capacitor should be close to the regulator IC and at least 100uF/25V. On the output side of the regulator you should have a minimum 10uF capacitor.

If the regulator gets too hot to hold comfortably for a few seconds securely between two fingers you need a larger regulator or add a heat sink. Remember, the capacitors must be close to the regulator so don't run long wires from the board to the regulator to get to the heat sink.

It is good practice to have decoupling capacitor near MCU and other major ICs. This decoupling capacitor should be 100nF in general. If your circuit is large complex one or has components spaced all over the PCB, (or Vero board or breadboard) include few 10uF capacitors among other components which are tied to +ve and ground lines. This improves power quality and stability all over the board.

Also it is good idea to connect LED through 330 ohm resistor, directly to your power supply output. When you have connected power-pack LED will lit and indicate you power is ON and will help you to avoid unfortunate accidents.

B. Power requirements of microcontrollers

Generally CMOS based microcontrollers ask for only about 5mA for itself. But complete project has other elements like resistors, capacitors, LED and ICs. All

together project will easily demand for 50mA to 100mA in general. Assuming it does not has motors, relays and servos like devices.

Since most of microcontrollers are CMOS devices they need very small average operating current. In most cases less than 5mA current is in microcontroller. But for reliable CMOS based microcontroller operation, we need to feed it with power supply which can supply 10 times or even 100 times more current peaks than normal average case.

There are some types of loads which likely to generate noise in power supply lines. Mostly these loads are inductive and examples are motors, servos, solenoid switches and relays. It is always good idea to supply this type of noisy devices with separate regulator than MCU power regulator. However it is OK to use same power source for both loads. Also this type of loads typically requires much higher currents than semiconductor based devices.

C. POWER SOURCE

The power will typically come from AC power supply or lead acid batteries which are named as power sources for us. The power supply can be mainly divided into two parts as power source and regulator. If regulator is properly designed and constructed, the power source is not that critical.

Simplest power source is likely to be AC/DC power-pack connected to AC outlet in house. If you supply regulator with this type of power pack, it should supply at least 5V above regulated output.

Data sheets for a typical regulator like 7805 says about 3V above out- put voltage is sufficient as input, but that doesn't allow for the extra ripple and the odd voltage dips that can occur with load and supply changes.

For a 5V regulator you should feed it with a measured 10V DC or more. At this supply voltage if you draw few hundred milliamps current from regulator, you will most likely need a heat sink on your regulator.

A typical 12V DC unregulated power-pack will have no load output of 14V to 18V. Current demand of about 50mA or more will pull this no load out put down by few volts.

D. REGULATORS

The common 7800 series voltage regulators are cheap reliable and simple enough to use in wide range of MCU based projects.

If your circuit consumes more than 1A of current, you have to consider voltage drops and power dissipation. Then component selection and application should be carefully designed. There are large numbers of commercial power a supply available that are not live up to their specifications and comes with reliability problems.

The 7805 is good for simple 5V MCU based projects. If a variable or different voltage is required, the LM317 is low priced alternative to 7805. Also we can find 7800 series based fixed voltage regulators like 7808, 7809, 7812 etc, where two digits after 78 indicates their positive output voltage. (ex. 7805 > 5V fixed, 7808 > 8V fixed) 7800 series and LM317 are linear regulators and hence they require input and output capacitors located close to the regulator to operate reliably. These capacitors should be used as minimum 100uF on input and minimum 10uF on output as general rule which always give good results. If you don't have these capacitors or they are too small, output can oscillate in high frequencies which also depend on output load and some other factors.

E. Understanding power quality and its effects on MCUs

For voltage measurement we commonly use multimeters. Actually multimeter does its job and shows us voltage. But what is this voltage? Usually multimeters shows us average for DC input and RMS voltage for AC input.

But a multimeter doesn't experience power quality and hence we can't get idea about power quality using multimeter only. In reality even if the multimeter shows 5V DC the MCU could still be feeling oscillations of power supply which may have peaks and dips much higher and lower than expected regulated output from regulator.

But how these dips and peaks give us problems? For example let's take MCU clocked with 4MHz oscillator. At this speed this MCU execute one instruction in 1uS time. (i.e. one millionth of Second!) If one instruction is go wrong during execution because of power problems, whole program in MCU will likely to go wrong way. This happens when power supply has oscillations larger

than 1 μ S in width for power surges. Remember we clock MCUs with 20MHz and higher rates for practical purposes which give us one instruction execution time 0.2 μ S or less.

To visualize power quality of your power supply, you should use good oscilloscope. This will show you spikes and dips in your power supply and how long they remain.

IV. ADVANTAGES

Soft starters are used on high tension motors for the following advantageous features:

- Smooth starting by torque control for gradual acceleration of the drive system thus preventing jerks and extending the life of mechanical components.
- Reduction in starting current to achieve break-away, and to hold back the current during acceleration, to prevent mechanical, electrical, thermal weakening of the electrical equipment such as motors, cables, transformers & switch gear.
- Enhancement of motor starting duty by reducing the temperature rise in stator windings and supply transformer.
- The microprocessor version of the Soft starter has a software controlled response at full speed which economizes energy, whatever may be the load. Because of the tendency to over specify the motor rated power, this feature has benefits for most installations- not only those where load is variable.
- The power factor improvement is a self-monitoring in built feature. When the motor is running at less than full load, the comparative reactive component of current drawn by the motor is unnecessarily high due to magnetizing and associated losses. Hence the voltage dependent losses are minimized with the load proportional active current component and as a result the power factor also improves simultaneously.

V. APPLICATIONS

- Steel industries (Rolling mills and processing lines)
- Cement industries

- Sugar plants
- Paper and pulp
- Rubber and plastic
- Textile industries
- Machine tool applications
- Power sector
- Water supply scheme
- And various process control applications

VI. CONCLUSION

Starting of induction motors is a process that can damage and influence characteristics and performances of the motor and electrical power systems, because of significantly higher starting current than the rated current. High voltage fluctuations, dips and sags, can occur in electrical power systems associated with the starting of the motor. A high current rise, di/dt during the transient process, is because of a presence of inherent capacitance of the power system elements, mainly capacitance of downstream cable. Main attention in design, development, and application of the soft starters was focused on protection of the motors, pulsating torques, harmonics, power system voltage sags and dips. Switching transients during “on” and “off” processes, current rise rate di/dt during switching “on”, and over voltages dv/dt during switching “off”, are major concern for the SCR driven Soft-Starter.

The SCR motor starter is based on parallel thyristors connected in reverse configuration to each other. An inductor can be inserted to limit the di/dt to the level that is safe for the SCRs operation. The inductor can be inserted before or after the SCRs, and must be inside the bypassing loop of the contactor. With the +bypassing of the SCR's including the inductor, it is not necessary to design it for continuous duty of the rated current.

With the bypassing of the SCRs including the inductor the inductor doesn't need to be designed for rated continuous current. This is very helpful in the design of the medium voltage soft starters because very often of the space limitations.

REFERENCES

- [1] A Damajnovic J. Johnson “Medium Voltage Soft Starter and Induction Motor Kit”, Patent No: US2013/0285502 A1.
- [2] Delcho Penkov & Alain Côte “Improve efficiently soft- starter transients' immunity”, Schneider Electric, White Paper.
- [3] Zhengyi Lu, Daozhuo Jiang and Zhaolin Wu “A New Topology of Fault-current Limiter and Its Parameters Optimization, Power Electronics Specialist Conference, 2003. PESC '03. 2003 IEEE 34th Annual Conference.
- [4] C. S. Chang, P. C. Loh, “Designs Synthesis of Resonant Fault Current Limiter for Voltage Sag Mitigation and Current Limitation”, Power Engineering Society Winter Meeting, 2000. IEEE, 2482 - 2487 vol.4
- [5] Bjorn Gustafson “Panel Session on Data for Modeling System Transients Insulated Cables”, Power Engineering Society Winter Meeting, 2001. IEEE, 718 - 723 vol.2
- [6] Adam John Wigington, “A Comparison of Induction Motor Starting Methods Being Powered by a Diesel Generator Set”, M.Sc. Thesis, University of Nebraska Lincoln, 2010.