

Smart Cities Waste Management System Using IoT

Nandini G.D¹, Dr. B.N Veerappa²

^{1,2}*Department of studies in computer science & Engineering, University BDT College of Engineering
(A constituent college of VTU, Belgavi), Davangere, Karnataka-577001, India*

Abstract- Waste accumulation administrations, today, are depleted and unfit to shoulder the weight of rising urban communities. It is one of the greatest progressing difficulties, being looked by creating economies, where a huge assortment of merchandise extending from vehicles to metal and equipment end up in insufficiently oversight and uncontrolled dumpsites, spreading infections and expanding contamination. In any case, the greater part of these plans have had the option to oversee squander once it has just been made. We, hence, propose a framework through a versatile application related with a Smart Trash Bin .The fundamental point of this application is to diminish HR and endeavors alongside the upgrades of a shrewd city vision. At customary interims dustbin will be squashed. When these brilliant receptacles are actualized on a huge scale, by supplanting our customary canisters present today, waste can be overseen effectively as it keeps away from pointless lumping of squanders on roadside. Rearing of creepy crawlies and mosquitoes can make aggravation around advancing unclean condition. This may even reason unpleasant maladies.

Index terms- Aurdino; GSM Modem; Ultrasonic sensor

I. INTRODUCTION

Ordinarily, in our city we see that the trash containers or dustbins set at open spots are over-burden. Prior when there was no degree for IOT, the waste was gathered intermittently by refuse authorities and was dumped in the landfill yards. Be that as it may, in this procedure there was no interceding of web. Thus this is a furious procedure which is time taking. At that point gradually after the headway of innovation has occurred, numerous arrangements were proposed. The current framework had three ultra-sonic sensors fixed to the dustbin to gauge the separation of the residue inside it. Yet, that isn't cost effective and furthermore needs more measure of vitality. Rather than utilizing a lot of containers in an unordered manner around the city, negligible number of savvy receptacles can be utilized. Utilizing just a single

sensor at the surface dimension rather than three makes it moderate as well as accomplishes a similar outcome.

The proposed framework utilizes the trend setting innovation than the current one. We utilize a GSM modem, a small scale controller and a ultra-sonic sensor. The ultra-sonic sensors are utilized to identify the separation of the garbage from the highest point of the canister. When the canister is full, utilizing the GSM modem we make an impression on the proprietor requesting that they void the receptacle. The application created will be a java program. At the point when the canister is full, the caution signal invokes indicating that the bin has to be emptied. Also there are LED lights that symbolize three different stages of fullness.

Municipal Waste Management System, so that the junk collectors will know of the time, to clear the bin at a particular location. If this system comes into exercise, it will be of great convenience to the user.

DESIGN

Smart bin is based on Aurdino board stage. It is interfaced with a GSM modem and the container is furnished with Ultrasonic sensor (HC-SR04). Likewise there is a buzzer and some LED's for the presentation of dimensions of residue in the receptacle.

Figure 1 demonstrates the square chart of a ultra-sonic sensor. The estimation of the time between a ultrasonic sign being sent and got is called as Ultrasonic detecting. The interim between these two sign is commonly alluded to as time-of-flight (ToF) and relies upon the separation the ultrasonic wave goes until it is reflected because of an impedance change and the speed of the ultrasonic wave. The essential condition $time = \text{remove}/\text{speed}$ can be utilized to gauge liquid dimension, liquid distinguishing proof/fixation, stream, or vicinity.

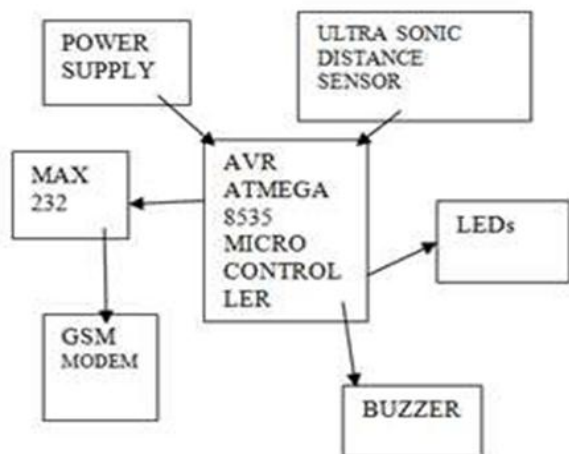

IMPLEMENTATION

In this paper, we use GSM modem to send the messages. It comprises of a GSM/GPRS modem with standard correspondence interfaces like RS-232 (Serial Port), USB, so it tends to be effectively associated with different gadgets. There are three LEDs that show three unique dimensions of stature of the loss in the canister. The green one shows that receptacle is unfilled and the red one demonstrates the container is full. At the point when the receptacle is full the ringer that is prepared, signals for multiple times with the goal that not any more waste is arranged into the canister. Along these lines, we can control the over streaming receptacles. At that point client will get a message saying that the dustbin must be arranged. This message is sent utilizing the GSM modem. The message can be sent to various individuals in the meantime. Figure 2 demonstrates the model that is created. Figure 3 demonstrates the message displayed.



Fig 2. Prototype model

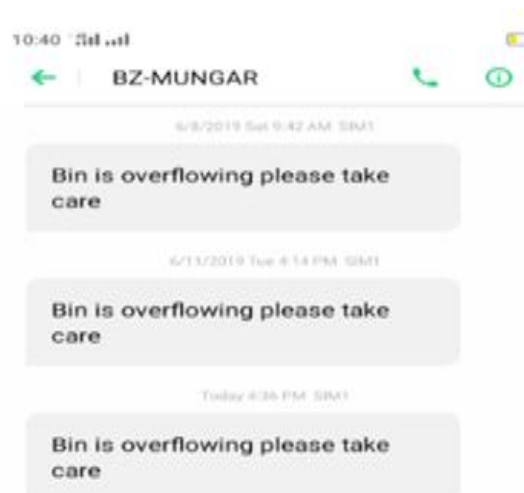

Fig. 3. prototype model – Message display

CONCLUSION

In this paper, implementation is done only for a single bin. Integration of many bins each with a unique ID can be done by implementing the principles of IOT and creating database for each bin which can be maintained by using SQL technology and a login webpage is created to ensure authorized entries

REFERENCES

- [1] Narayan Sharma, Nirman Singha, Tanmoy Dutta, “Smart Bin Implementation for Smart Cities” , International Journal of Scientific & Engineering Research, vol 6, Issue 9, 2015,pp-787-789.
- [2] City Garbage collection indicator using RF (Zigbee) and GSM technology”
- [3] Basic Feature, “Solid waste Management Project by MCGM
- [4] M.T.H. Shubho, M.T Hassan, M.R. Hossain and M. N. Neema, “Quantitative Analysis of Spatial Pattern of Dustbins and its Pollution in Dhaka City--A GIS Based Approach”, Asian Transactions on Engineering (ATE ISSN: 2221-4267) vol. 03 Issue 04, September 2013, pp.1-7.
- [5] Narayan Sharma, Nirman Singha, Tanmoy Dutta, “Smart Bin Implementation for Smart Cities”, International Journal of Scientific & Engineering Research, Volume 6, Issue 9, September-2015, pp.787-791.

- [6] Insung Hong, Sunghoi Park, Beomseok Lee, Jaekeun Lee, Daebeom Jeong, and Sehyun Park, "IoT-Based Smart Garbage System for Efficient Food Waste Management", The Scientific World Journal, Volume 2014 (2014), Article ID 646953, 13 pages