

Forest Preventive System by using Microcontroller and GPS System

Asmita Gorde¹, Kunal Kore²

^{1,2} Computer Department, SPCOE College/ Pune University, India

Abstract- Nowadays smuggling of trees is a big problem. Our project is deals saving the important and precious trees like sandal, sagwan etc from being harvested or smuggled. As name suggests here we are saving trees by using accelerometer sensor, GPS and GSM module. These trees are very costly as well as less available in the world. These are used in the medical sciences as well as cosmetics. Because of huge amount money involved in selling of such trees woods lots of Karnataka and Tamil nadu notorious smuggler “Virrappan” did the smuggling of such trees for so many years. To restrict such smuggling and to save the forest around the globe some preventive measures need to be deployed. We are developing such a system which can be used to restrict this smuggling. In our project, every tree will be equipped with small electronic unit consisting of a micro controller, accelerometer sensor and GPS and GSM module. The data of different tree units can be controlled by this Unit. The unit will send the data in the form of text message to concern forest authority with the help of GPS and GSM module. This data can be used by concerned forest authorities to take preventive action.

Index terms- GPS, GSM Module, Accelerometer Sensor Microcontroller, Power Supply

I. INTRODUCTION

For many days we are reading in the newspapers about smuggling of the trees like Sandal, Sagwan etc. These trees are very costly as well as less available in the world. These are use in the medical sciences as well as cosmetics. Because of huge amount of money involved in selling of such tree woods lots of incidents are happening of cutting of trees and their smuggling. In India also in the jungles of Karnataka and Tamilndu notorious Smuggler Virrappan did the smuggling of such trees for so many years. From the Earth Report (2000) in mind it’s not surprising that the combination of excessive demand and shortage of supply for East Indian Sandalwood oil from Santalum

album has lead to the prices rising to around 700-750Kg in recent months. Worries about the present sustainability of Sandalwood supplies, lead to a clampdown on Sandalwood harvesting and distillation by the Indian authorities in 1995, so that by now much or most of the El. Sandalwood oil coming onto the market is smuggled.

The international essential oil trade itself tends to be tight-lipped about its precise sources of the oil. Anon (2002) reports that mobile squads of Forest Department officials in Chitradurga, and Shimoga districts to curb sandalwood smuggling from the 30 or so private sandalwood-based factories in Andhra Pradesh close to the Karnataka border.

II. MATERIAL AND METHODS

This prospective comparative study was carried out on Trees for Forest Department of all over the world for saving the trees from smuggling.

Hardware used for project

1. Micro Controller PIC(16F877A)
2. GPS Module
3. GSM modem
4. 16*2 LCD display
5. MAX 232 Protocol

Procedure methodology-

We have included different component which play an important role and we Split the block diagram in different module as GPS and GSM module and also include the importance of each module.

Sensor used in system is accelerometer sensor. We consider a mobile WSN consisting of a set of sensor nodes and a mobile collector. Each sensor has a single antenna and sensors are statically and randomly scattered over the sensing field. At the same time, we deploy a mobile collector to

periodically start a data gathering tour from the sink node, and in each tour it visits some pre-determined anchor nodes in the field and stays at each anchor node for a period of time to collect data from nearby sensors via multi-hop transmissions.

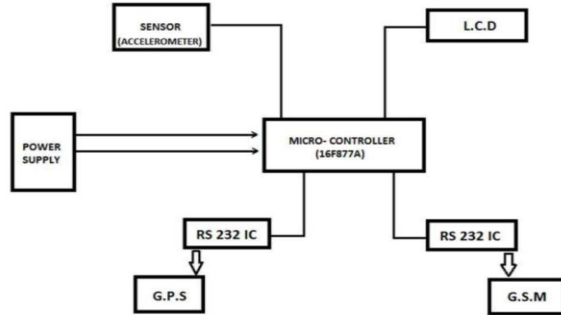

A system is made which can;

1. Detect the cutting of tree and
2. Perform follow up actions like co-ordinate detection of place of accident and wireless request for help automatically.

In short system detects the precise geographic location of the tree where the smuggling has occurred and automatically sends a prerecorded SOS message to some prerecorded numbers for rescue. Serial communication: The serial communication is used to transfer the data between the mobile device and the

microcontroller. The GSM modem and the GPS model are connected to the microcontroller through an IC known as MAX232. The serial communicator that will be used is MAX 232.

The GPS model is wirelessly connected to the satellite and is continuously giving the exact location in longitude and latitude to the microcontroller through its Antenna. The GPS model is known as Global Positioning System.

Now as soon as the sensor give signal to the microcontroller the MC tends the data i.e. the latitude and the longitude provided by the GPS model and give the information to the GSM modem through serial communication for sending the message to the Mobile number programmed The GSM modem has a SIM card inserted in it for it to send the SMS and it functions on the basis of AT Commands. At the same time the microcontroller 16F 877A also displays the information on the LCD (Liquid Crystal Display)

Circuit Diagram

The figure below shows the schematic circuit diagram of system It mainly includes sensors, display unit, GPS and GSM unit, Micro-controller and Power Supply.

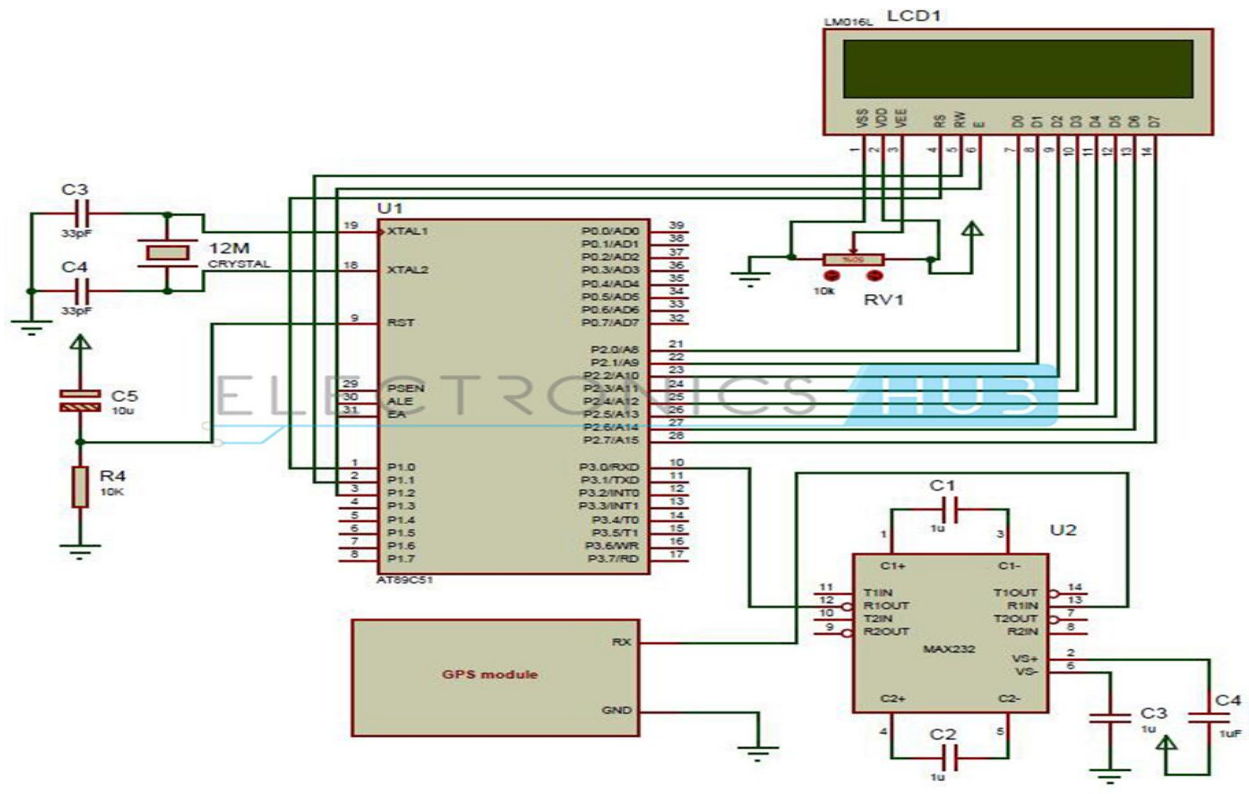

III.RESULT

Three distinct units are placed in proper places for performing experimental test. fully setup of system is established. Stroke has been given and it is being detected by tree unit. Further processing of signal is done by sub server unit. For understanding purpose LCD display we have attached. At control station where main unit is fixed, detected signal is successfully received by GSM module. For displaying purpose GUI is maintained which will display a message or alarm indicating that particular tree is undergoing non-bearable pressure.

IV. DISCUSSION & CONCLUSION

In this paper, we are using accelerometer sensor, GPS and GSM module, MAX232, PIC controller. The purpose of using accelerometer sensor is that when sensor gets vibrated resistance across sensor males: result in variation in voltage across it. The GSM and GPS module used for transmitting data in the form SMS (short message service) text messages along with location of trees to concern authority. Smuggling of trees is a trans-national problem. The high profits involved in the illegal trade of trees provide incentives for smugglers to launder illegal trees for sale on international markets. This project argues how an anti-corruption approach to the problem may help to finally break the trafficking chain.

REFERENCES

- [1] Prasad R. Khandar, K. Deivanai, "Preventive system for forests", International Journal of Computer Science Trends and Technology (IJCST) – Volume 4 Issue 1, Jan - Feb 2016.
- [2] S. Guo, C. Wang and Y. Yang, Joint Mobile Data Gathering and Energy Provisioning in Wireless Rechargeable Sensor Networks,, IEEE Trans. Mobile Computing, vol. 13, no. 12, pp. 2836-2852, Dec. 2014.
- [3] C. Wang, J. Li, F. Ye and Y. Yang, NETWRAP: An NDN Based Real-Time Wireless Recharging Framework for Wireless Sensor Networks, , IEEE Trans. Mobile Computing, vol. 13, no. 6, pp. 1283-1297, June 2014.
- [4] C. Wang, J. Li, F. Ye and Y. Yang, Recharging Schedules for Wireless Sensor Networks with

Vehicle Movement Costs and Capacity Constraints, IEEE SECON 2004, pp. 468-476, 2014.

- [5] K. Huang and V. K. N. Lau, Enabling Wireless Power Transfer in Cellular Networks: Architecture, Modeling and Deployment, , IEEE Trans. Wireless Comm., vol. 13, no. 2, pp. 902-912, Feb. 2014.
- [6] Y. Yang and C. Wang, Wireless Rechargeable Sensor Networks, Springer, 2015.
- [7] D. W. K. Ng, E. S. Lo and R. Schober, Wireless Information and Power Transfer: Energy Efficiency Optimization in OFDMA Systems,, IEEE Trans. Wireless Comm., vol. 57, no. 6, pp. 6352-6370, Dec. 2013.
- [8] R. Zhang and C. K. Ho, MIMO Broadcasting for Simultaneous Wireless Information and Power Transfer, , IEEE Trans. Wireless Comm., vol.12, no. 5, pp. 1989-2001, May 2013.
- [9] X. Zhou, R. Zhang and C. K. Ho, Wireless Information and Power Transfer: Architecture Design and Rate-Energy Tradeoff, , IEEE Trans. Comm., vol. 61, no. 11, pp. 4754-4767, Nov. 2013. Ikit for Natural Language Interface Construction.