

IOT Based Smart Irrigation System Using Raspberry Pi

Arpitha Shankar S I

Assistant Professor, GSSSIETW, Mysuru

Abstract- Water is the important source in human life. Around 80 % to 90 % water used in agriculture field. As due to day by day growth in globalization and population water consumption is also increases. There is challenge in front of every country to reduce the farm water consumption and provide fresh and healthy food. Today automation is one of the important role in human life. The system is not only provides comfort but also reduce energy, efficiency and time saving. Whenever there is a change in temperature, humidity and current status of rain of the surroundings these sensors senses the change in temperature and humidity and gives an interrupt signal to the raspberry pi. Now a day the industries are using an automation and control machines which are high in cost and not suitable for using in a farm & garden field. So in this work we design a smart irrigation technology based on IOT using Raspberry pi. The system can be used to control the water motor automatically and can also monitor the growth of plant by using webcam. We can watch live streaming of farm on mobile phone using suitable application by using Wi-Fi network. Raspberry pi is the main heart of the overall system.

Index terms- Raspberry Pi, Wi-Fi, Sensors, IOT, automation

I. INTRODUCTION

India is one of the largest freshwater user in the world, and our country uses large amount of fresh water than other country. There is a large amount of water used in agriculture field rather than domestic and industrial sector. 65% of total water is contributes as a groundwater. Today water has become one of the important source on the earth and most of used in the agriculture field. As the soil-moisture sensor and temperature sensor are placed in the root zone of the plants, the system can distributed this information through the wireless network. The raspberry pi is the heart of the system and the webcam is interfaced with Raspberry pi via Wi-Fi Module. Python programming language is used for automation purpose. The system is a network of wireless sensors and a wireless base station which

can be used to provide the sensors data to automate the irrigation system. The system can use the sensors such as soil moisture sensor and soil temperature sensor and also ultrasonic sensor. The raspberry pi model is programmed such that if the either soil moisture or temperature parameters cross a predefined threshold level, the irrigation system is automated, i.e. the relay connected to the raspberry pi will turn ON or OFF the motor. This paper presents an efficient, fairly cheap and easy automated irrigation system.

This system once installed it has less maintenance cost and is easy to use. By using the webcam with suitable application on mobile phone we can easily online monitoring the actual situation of the field and sensors such as soil moisture and temperature are used to provide the information about changes occurs in the field. It is more advantageous than the traditional agriculture techniques.

II. RELATED WORK

After extensive research in the agricultural field, many researchers found that the agriculture area and its productivity are decreasing by the day. With the Use of different technology in the field of agriculture we can increase the production as well as reduce manual efforts. This paper shows the technology used in agriculture sector based on IOT and Raspberry Pi. Chandan kumar Sahu proposed a system on “A Low Cost Smart Irrigation Control System”. It includes a number of wireless sensors which are placed in different directions of the farm field. Each sensor is integrated with a wireless networking device and the data received by the “ATMEGA318” microcontroller which is on the “ARDUINO-UNO” development board. The Raspberry pi is used to send various types of data like text messages and images through internet communication to the microcontroller process [1]. Supraha Jadhv proposed, automated irrigation system using wireless sensor network and

raspberry pi that control the activities of drip irrigation system efficiently [2]. Sebastian Hentzelt proposed a paper on the water distribution system and gave results to decompose the original nonlinear optimal control problem (OCP) [3]. Joaquin Gutierrez attempted a paper that research automated irrigation system using a wireless sensor network and GPRS module instead of the Raspberry pi [4]. Ms. Deweshvree Rane Proposed “Review paper based on Automatic Irrigation System Based on RF Module” it is based on the RF module, this device is used to transmit or received radio signal between two devices. It’s design is complex because of the sensitivity of radio circuits and the accuracy of the components [5]. Karan Kansara proposed “Sensor based automatic irrigation system with IoT”, this irrigation system is used a rain gun pipe, one end connected to the water pump and another to the root of plant. It doesn’t provide water as a natural rainfall like sprinkler and also it uses only soil moisture sensor [6]. G. Parameswaran proposed “Aurdino based smart irrigation system using Internet of Things”, the researcher has not used Raspberry pi instead the work is done using aurdino controller without use of soil moisture sensors [7].

III. PROPOSED SYSTEM

The block diagram of the proposed system as shown in Fig.1 and Fig.2. The main components of this diagram are Sensors, Raspberry Pi module, Wi-Fi connection, LDR, relay, motor, and lamp.

1. Transmitting section

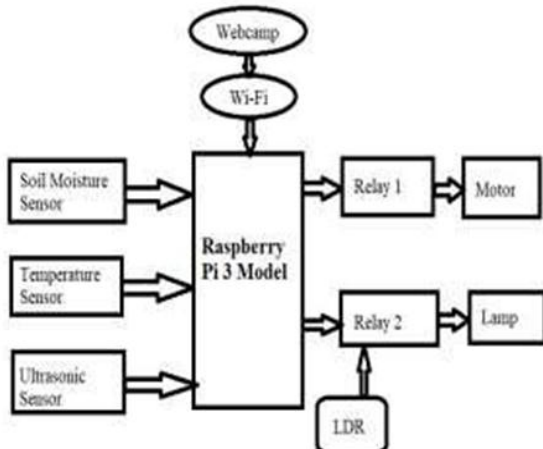

Fig 1: Irrigation Control System (Transmitting Section)

The above figure shows that main block diagram of Irrigation control system. In that main model is Raspberry pi 3 model, Relays, LDR, Sensors. In this control system three sensors are such as soil moisture sensor, temperature sensor, ultrasonic sensors are connected to the raspberry pi 3 model also Wi-Fi connection is connected to the model. The connection of raspberry pi is given to the relay 1 and relay 2 which are again given to the motor and lamp respectively. LDR connection is given to the relay 2.

2. Receiving section

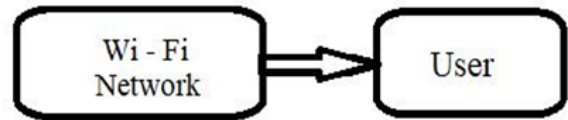

Fig 2: Monitoring Unit (Receiving Section)

Above figure shows that receiving section of the main module i.e Monitoring unit. In that two section are present one is Wi-Fi network and user. This connection again given to the raspberry pi 3 module.

3.2. SENSORS

A sensor is a device, module, or subsystem whose purpose is to detect events or changes in its environment and send the information to other electronics, frequently a computer processor. In short sensors are the device which converts the physical parameter into the electric signal. A sensor's sensitivity indicates how much the sensor's output changes when the input quantity being measured changes. The system which shown in fig.1 consists of

- Soil moisture sensor- used to measure the moisture content of the soil.
- Temperature sensor - used to detect the temperature of the soil.
- Ultrasonic sensor - used to measure the water level in the water tank.



Fig 3.2.1: Soil Moisture Sensor



Fig 3.2.2: DHT 11(Temperature Sensor)

3.3. RASPBERRY PI

Raspberry Pi is a small sized single board computer which is capable of doing the entire job that an average desktop computer does like spread sheets, Word processing, Internet, Programming, Games etc. It contain 1GB RAM, 2 USB, ARM V8 Processor and an Ethernet port, HDMI & RCA ports for display, 3.5mm Audio jack, SD card slot (bootable), General purpose I/O pins, runs on 5v.



Fig 3.3: Raspberry Pi Model

3.4 RELAY

A relay is an electrically operated switch. Relays are used where it is necessary to control a circuit by a separate low-power signal. A relay with calibrated operating characteristics and sometimes multiple operating coils are used to protect electrical circuits from overload. As shown in above figure raspberry pi is connected to the devices via relay. Here relay can be operated as switch to on or off the devices.



Fig 3.4: Relay

IV. WORKING PRINCIPLE

As the Raspberry Pi is the heart of the system. This system contains webcam which is interfaced to Raspberry Pi via Wi-Fi module. The Raspberry Pi Model zero incorporates a number of enhancements and new features. This features of raspberry pi are improved power consumption, increased connectivity and greater IO which made this powerful, small and lightweight ARM based computer. The Raspberry Pi cannot directly drive the relay. It has only zero volts or 3.3 V. It needs 12V to drive electromechanical relay. In that case it uses a driver circuit which provides 12V amplitude to drive the relay. Various sensors are connected to the Raspberry Pi board give a resistance variation at the output. This output signal is applied to the comparator and signal conditioning circuit which has potentiometer to decide the moisture level above which the output of comparator goes high. This output signal is given to the Raspberry Pi board. If the soil moisture value is above the moisture level then the 3 phase induction motor will be OFF, whereas if the moisture level is low motor will be ON through the relay. LDR (Light Dependent Resistor) is used to control the light automatically and by using this we can monitor the farm at night also.

V. WORK FLOW OF THE SYSTEM

- Step 1: Start.
- Step 2: The system can be initialize on Raspberry Pi.
- Step 3: The water level sensor constantly checks for the water level of the motor.
- Step 4: The soil moisture sensor checks the soil moisture level constantly.
- Step 5: The USB camera installed with the Raspberry Pi gives the complete lookout of the field and this can be monitored in the internal network system.
- Step 6: The sensor constantly senses the temperature and humidity of the field and updates the date in the web server.
- Step 7: If the permissible level of water is reduces, then the relay which is connected to the Raspberry Pi will turn ON the motor.
- Step 8: Similarly, if the soil becomes dry, the motor which is connected to the relay will be turned ON to wet the field.

Step 9: If the step 8 is completed, it will go to the step 4.

Step 10: Similarly, if the step 7 is over, the command will go to the step 3.

VI. HARDWARE PART AND RESULT



VII. CONCLUSION

The smart irrigation system is suitable and cost effective for advance water resources for agricultural production.

The system would provide feedback control system which will monitor and control all the activities of plant growth and irrigation system efficiently. If rain gun sensor can be added so that when it rains there won't be floods. Rain water harvesting can be done and this harvested water can be used to irrigate fields. We can also include many more water quality sensors that affect the crops.

REFERENCES

- [1] Chandankumar Sahu, Pramitee Behera. 2015 A Low Cost Smart Irrigation Control System IEEE Sponsored 2nd International Conference on Electronics and Communication System (ICECS).
- [2] Suprabha Jadhav, Shailesh Hambarde. 2013 Automated Irrigation System using Wireless Sensor Network and Raspberry pi, International Journal of science and research (IJSR).
- [3] Gutierrez, J. Francisco, J. Villa-Medina Nieto-Garibay, A., and Angel, P.G. 2013. Automated Irrigation System Using a Wireless Sensor Network and GPRS Module

[4] Rane D, Indurkar P, and Khatri, D.M. 2015 Paper based on Automatic irrigation system on RF module In IJAICT Volume 1, Issue 9.

[5] Kansara, K., Zaveri, V., Shah, S., Delwadkar, S., Jani, K. 2015 Sensor Based Automated Irrigation System with IOT In IJCSIT, Vol. 6.

[6] Parameswaran, G., Sivaprasath, K. 2016 Arduino Based Smart Drip Irrigation System Using Internet of Things in: IJESC, Volume 6 Issue No. 5.