

Implementing Perturb & Observation MPPT with Buck and Boost Converter

P. Keerthana¹, M. Vasavi Uma Maheshwari²

¹M.Tech, Electrical and Electronics Engineering (Power Systems), Acharya Nagarjuna University, Guntur, Andhra Pradesh

²Asst. professor, Electrical and Electronics Engineering (Power Systems), Acharya Nagarjuna University, Guntur, Andhra Pradesh

Abstract- Utilization of wind farm in generating electrical energy has taken a supreme role all over the world. Renewable energy source are ecofriendly technology mainly due to avoiding pollution like Global warming, harmful gases as of from conventional source, and dust, heavy sounds etc. In this MPPT techniques are used at power electronic circuit to extract maximum energy from wind farm. Currently the power production is done with Doubly fed Induction Generator (DFIG) adopted in wind farm plays a major role. This paper seeks for implementing perturb& observation MPPT with buck and boost converters. The simulation results are accomplished in MATLAB/SIMULINK/SIMPOWER SYSTEM.

Index terms- MPPT, wind farm, active and reactive powers, buck converter, boost converter, conventional P&O

1. INTRODUCTION

The electrical requirements of the world including India are increasing at alarming rate and power demand has been running ahead of supply. Although conventional sources of energy (i.e. coal, petroleum and natural gases) and other conventional resources are balancing of electric scarcity. As per 20th century Renewable energy source (i.e. wind, solar and Geo thermal energy) play a virtual role to reduce over pollution.

Presently the Wind farm generation is highly performing a wide role in the production of electricity due to its advantages like inexhaustible, pollution free, reduction of usage of fossil fuels and reducing the energy imports etc. the wind energy is huge air flow when it flows on Aero turbine it converts Kinetic energy of moving air into rotary mechanical energy by the blades of turbine and then turn into electrical power through the generators.

Then the generated energy is transferred into grid through the transformer and transmission line. Wind energy is captured by aero dynamically designed blades which convert the kinetic energy to mechanical energy in terms of MW (megawatts) of energy by low speed and high torque power to electrical power is transferred by a gear box coupled to the shaft of generator with constant speed.

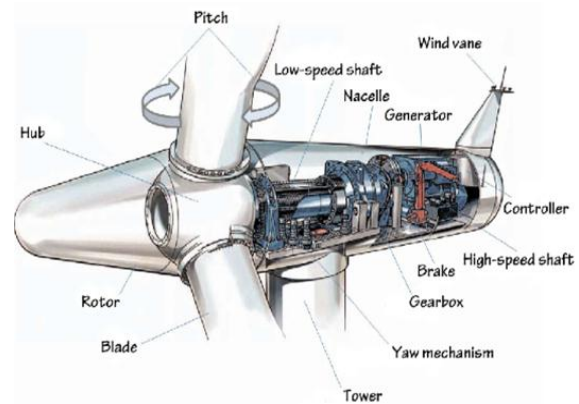

1.1 GENERATOR SYSTEM FOR WIND FARM

Based on Energy flow from gear box to generators there are two types of generators available to produce energy are induction and synchronous generators. In Induction generators there are three types cage rotor, wound rotor with slip ring and double fed induction generator. Induction generator can be used fixed and variable wind speed .doubly fed induction generator are fundamentally electrical machines that are fed ac current from stator and rotor. The wound rotor Induction motor also operates as double fed electrical machines (DFEM). The power flow from rotor the windings in DFEM can operate be either as a motor or as a generator ,based on the wind speed a machine when runs above the synchronous speed it is generator or If it runs below the synchronous it is

acting motor. The primary advantages of DFIG is wind farm allow amplitude and frequency from their output voltage to maintain constant value. No matter of speed Air blowing to the aero turbine to rotor due to DFIG is directly connected to alternative current (AC) and synchronism take place. This has the ability of control the power factor and power electronic devices are inserted at moderate size. Briefly about DFIG is containing two converters Rotor side converter and Grid side converter. The DFIG is connected to rotor side converter back to back Grid side converter between these two converters energy storage is placed known DC link capacitor in order to keep voltage constant from rotor side converter it is easy to control torque or speed and power factor of DFIG. At stator the grid is indirectly connected to DFIG so this terminal keeps the dc link constant. Usually induction generator not takes reactive power itself so the DFIG is connected to grid it takes reactive power under fault condition it fail due to overtake of reactive power .thus converter are used for balancing reactive power.

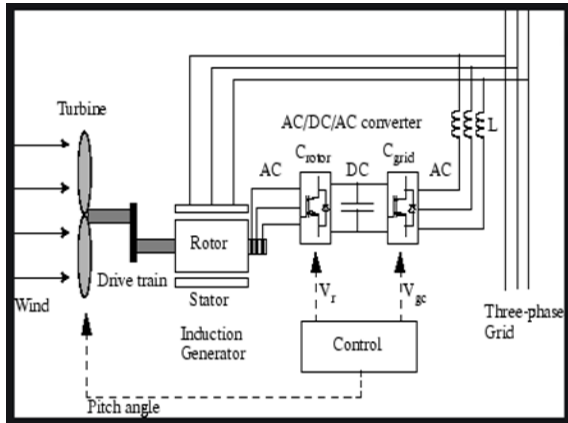

Block diagram of Doubly fed Induction Generator (DFIG)

2 POWER CONTREOLERS

This explains about controller play a major role. The system is has rotor, stator, speed, generator, motor are controller by reference value. So the MPPT is used because in some cases it track maximum amount of energy. Based on MPPT power extraction is more up to certain point so current, voltage, speed and rotor are measured.

In this wave farm variable wind speed is taking due to DFIG it is a back to back power converters.

Connected to rotor of the generator. From this stator directly connect to grid .however this converter decouple mechanical and electrical frequency make variable speed possible so it can vary electrical rotor speed.

Basically it is DFIG system so control system includes electrical control of convert system .pitch angle controller of the blade limit the power when wind farm is above the rated speed.

In the perturbation and observation method rotor speed changes and output power is observed in order to regulate the next change in rotor speed

P&O method regulates turbine speed accordingly to comparison in wind generator

P&O method has high certainly, low complexity, and low cost because it does not required anemometer to measure the wind speed and also there is no need to have knowledge of system specifications

Kinetic energy if wind farm

$$E_k = 1/2 mv^2 \quad [2]$$

Where m= air mass

E_k =kinetic energy

Mass m is expressed as follow

$$m = \rho (Ad) \quad [3]$$

ρ - Air density (kg/m³)

A- Swept area of rotor blade(m²)

d- Distance travelled by the wind (m)

The actual power received by turbine power output

$$P_w = 1/2 \rho \pi R^2 V_w^3 \quad [4]$$

Where p_w is input power for wind farm, R is for radius of blades and v_w is for wind speed

From the maximum power theorem states that source can be transferred when load resistance R_L is equal to the internal resistance (r) of the source ($R_L = r$).

$$I_L = \frac{V_{th}}{R_{th} + R_L} \quad [5]$$

The power absorbed by the load is

$$P_L = I_L^2 * R_L \\ = \left[\frac{V_{th}}{R_{th} + R_L} \right]^2 * R_L$$

From above expression the power delivered to R_{Th} and R_L are equal the power delivered from this equivalent source to the load entirely depend on the load resistance R_L to find the exact value of R_L with respected to 0 the equation are below

$$\frac{dp(R_L)}{dR_L} = V_{Th}^2 \left[\frac{(R_{Th} + R_L)^2 - 2R_L * (R_{Th} + R_L)}{(R_{Th} + R_L)^4} \right] = 0 =$$

$$(R_{Th} + R_L) - 2R_L = 0$$

$$R_L = R_{Th} \quad [6]$$

Due to that the MPPT of sub system the voltage and current are tracking maximum amount of power at certain point as shown in the mat lab

From these certain point MPPT is tracked power with current and power with voltage as show in the mat lab due to duration of time MPPT is obtain the output result is based on duty cycle as MPPT changes duration of time duty cycle also change.

Velocity	Input voltage V_{dc}	output voltage V_{dc}	Current (pu)	Power dissipated	Duty cycle $\frac{V_{in}}{V_{out}(V_{dc})}$
1.2 km/hr (15m/sec)	250v	1180v	2.41(pu)	600w	0.235
1.3km/hr	240v	1020v	2.48(pu)	580w	0.3
1.4km/hr	200v	1040v	3.61(pu)	650w	0.35
1.5km/hr	180v	1060v	3.71(pu)	700w	0.428
1.6km/hr	160v	1080v	0.46(pu)	750w	0.488

3 POWER CONVERTERS

Solid state power converters are employed for obtaining the appropriate from of electrical energy such as direct current or adjustable – frequency, alternating current AC-DC-AC in wind farm.

Power transistor are generally BJTS MOSFET, IGBT are current control devices in the DFIG these are used due to control of current these are used as DC/DC converters are essentially circuit involving IGBT, MOSFET based switch to obtain a regulated output voltage level. Mosfet switch are used where fast switching frequency is required .IGBT is selected where there is need for high voltage tolerance.

3.1 IGBT (Buck converter)

Insulated gate bipolar transistors are used in mat lab for buck converter in put voltage is grater then desired output voltage. In these some semiconductor are added like diode transistor. However some storage like capacitor and inductor are added. These are DC/DC converters. This provides good efficiency and free from voltage ripples, voltage swells, filters hence it is called step down converter.

Schematic diagram of buck converter

3.2 MOSFETs (Boost converter)

MOSFETs are used in mat lab it just acts like a boost converter because the input current decreases and output voltage increases. It is switch and control the current boost converter are used as switch a voltage at lower level to higher level at same power hence they are also called step up converter.

In these some semi converters are diode and transistor from these switch they avoid voltage ripples and filters in these storage practical are capacitor and inductor to store energy.

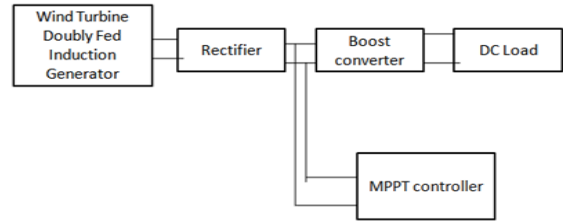

Schematic diagram of boost converter

During time for the switch is closed. The inductor change the associated circuit is as depicted as shown in fig 3.1&3.2 during the time when the switch is open the developed voltage is pushed to the load through the diode and capacitor

The average value or the DC value of the pulse produced is given by

$$V_o = V_s / (1-D)$$

Where V_o refers to output voltage of DC component, V_s is voltage source and D is the duty cycle of switching. Duty cycle is defined as

$$T_{on} / (T_{on} - T_{off})$$

Where T_{on} is the on time of the converter

T_{off} is the off time of the converter

At certain maximum point the power tracks at certain starting point of time to ending point of time declares duty cycle the discrete $T_s = 5e-0.5$ For this system.

SIMULINK MODAL WIND FARM- DFIG DETAILED MODAL

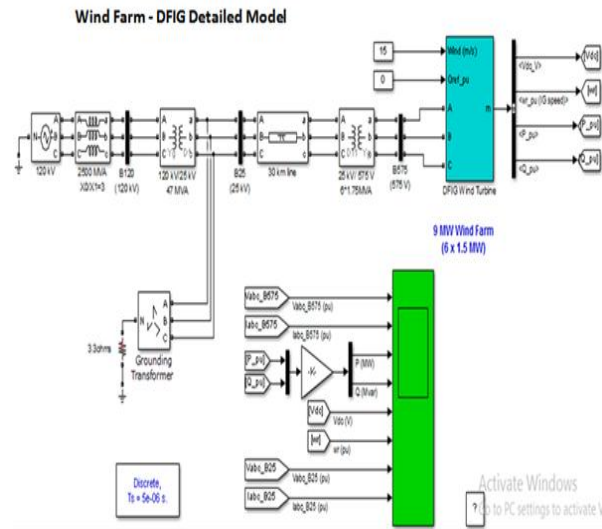

3.1 SIMULINK MODAL FOR BUCK CONVERTER

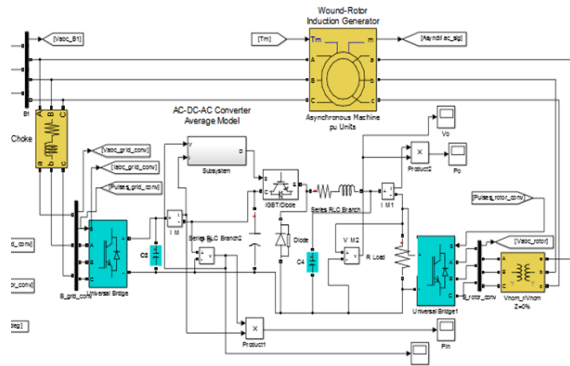

3.2 SIMULINK MODAL FOR BOOST CONVERTER

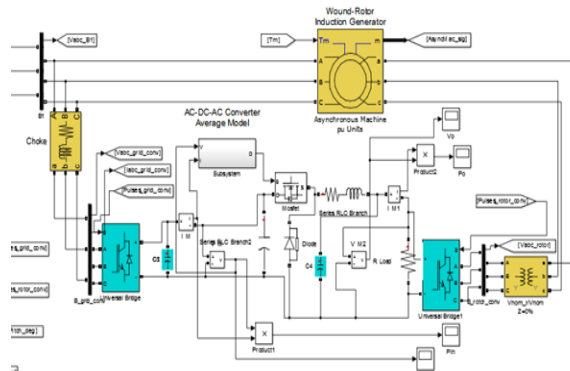

3.1.2 SUB CONVENTIONAL P&O MPPT CONTROL METHOD SYSTEM

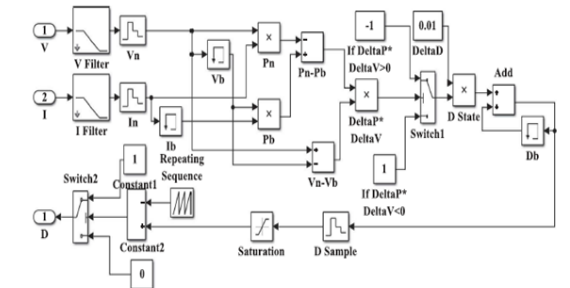

3.3 TABULAR FORM:

Wind speed	Tuning Resistance	Tuning Inductor	Tuning capacitor	Simulation time	Power Dissipated
15(m/s)	0.005ohm	5e-3	C ₁ = 250e-6 C ₂ = 0.03e-6 C ₁ = 120e-6	5e-05s	9MW
15(m/s)	0.2ohm	5e-3	C ₁ = 300e-6 C ₂ = 0.04e-6 C ₁ = 130e-6	5e-05s	9.1MW
15(m/s)	0.3ohm	5e-3	C ₁ = 400e-6 C ₂ = 0.05e-6 C ₁ = 150e-6	5e-05s	8.3MW
15(m/s)	0.03ohm	4e-3	C ₁ = 200e-6 C ₂ = 0.05e-6 C ₁ = 120e-6	5e-05s	8.9MW
15(m/s)	0.004ohm	4e-3	C ₁ = 200e-6 C ₂ = 0.03e-6 C ₁ = 300e-6	5e-05s	8.7MW

Table3.3.1 output of conventional P&O with MPPT controller for Buck converter

wind speed	Tuning Resistance	Tuning Inductor	Tuning capacitor	Simulation time	Power Dissipated
15(m/s)	0.005ohm	5e-3	C ₁ = 250e-6 C ₂ = 0.03e-6 C ₁ = 120e-6	5e-05s	8.99MW
15(m/s)	0.004ohm	3e-3	C ₁ = 200e-6 C ₂ = 0.02e-6 C ₁ = 110e-6	5e-05s	9MW
15(m/s)	0.005ohm	1e-3	C ₁ = 150e-6 C ₂ = 0.01e-6 C ₁ = 100e-6	5e-05s	9.3MW

Table 3.3.2 output of conventional P&O with MPPT controller for Boost converter

4 RESULT OF BUCK AND BOOST CONVERTERS

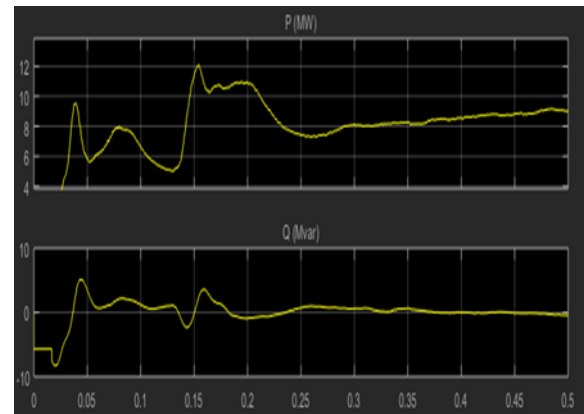

Fig 4.1 Output of P&O by using Buck converter

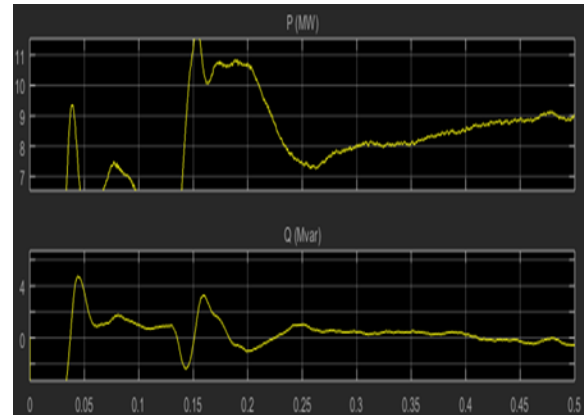

Fig 4.2 Output of P&O by using Boost converter

5 CONCLUSIONS

Implementing perturb and observation MPPT with buck and boost converters are proved. From this

DFIG wind farm by using MPPT controller the power dissipated is high in boost converter compare to buck converter

REFERENCE

- [1] Mohammad Junaid Khan and Lini Mathew, 2018. Comparative Analysis of Maximum Power Point Tracking Controller for Wind Energy System .ISSN:0020-7217. International Journal of Electronics
- [2] M.V.T.L. Ravi Kumar Mada, CH .Srinivas, K. Shashidhar Reddy, 2012. Double fed induction generator for variable speed wind energy conversion system-modeling & simulation. ISSN:2319-8885, Volume01 Issue No.03
- [3] Joseph George 1988, a variable duty cycle maximum power point tracking algorithm for wind energy conversion system, 2011. Electronic theses and Dissertations, Paper716.
- [4] Badrul H. Chowdhury, Srinivas Chellapilla, 2005. Double fed induction generator control for variable speed wind power generation. Electrical power system research 786-800
- [5] Yujia Zhang, Lei Zhang and Yongwen Lin, 2019. Implementation of maximum power point tracking Based on variable speed forecasting for wind energy system
- [6] Shwehlaing, 2014. Basic concepts of Doubly Fed Induction Generator driven by wind energy conversion system.ISSN2319-8885, Vol-03, Issus.15