

# Electricity Generation Using Solar Power

Swapnil Namekar<sup>1</sup>, Prasad Kalijkar<sup>2</sup>

<sup>1</sup>Assistant Professor, Electrical Department, BVDUCOEP, Pune

<sup>2</sup>Student, Electrical Department, BVDUCOEP, Pune

**Abstract-** Solar energy affords great potential for conversion into electric power. This paper deals with the electricity generation using solar power. The proposed system ensures the optimization of the conversion of solar energy into electricity by properly orienting the panel in accordance with the position of the sun. The operation of the paper is based on a Stepper motor intelligently moves a panel according to the light intensity of the sun sensing by light sensor.

## 1. INTRODUCTION

Renewable energy is rapidly gaining importance as an energy resource as fossil fuel prices fluctuate. At the educational level, it is therefore critical for engineering and technology students to have an understanding and appreciation of the technologies associated with renewable energy. One of the most popular renewable energy sources is solar energy. Solar energy is the most abundant stream of energy. It is available directly as solar isolation and indirectly as wind energy. Sun sends out energy in the form of electromagnetic radiation. Its potential is 178 Billion MW, which is about 20,000 times the world's demand. Some of the Solar Energy causes evaporation of water, leading to rains and creation of rivers etc. Some of it is utilized in photosynthesis which is essential for sustenance of life on earth. Man has tried from time immemorial to harness this infinite source of energy. But has been able to tap only a negligibly fraction of this energy till today.

Many researches were conducted to develop some methods to increase the efficiency of solar panels. One such method to increase is to employ a solar tracking system.

Solar tracking enables more energy to be generated because the solar panel is always able to maintain a perpendicular profile to the sun's rays. Development of solar panel tracking systems has been ongoing for several years now. As the sun moves across the sky during the day, it is advantageous to have the solar

panels track the location of the sun, such that the panels are always perpendicular to the solar energy radiated by the sun. This will tend to maximize the amount of power absorbed by system. In general, there are three methods to increase the efficiency of PV systems. The first method is to increase the generation efficiency of solar cells; the second one is related to the energy conversion system included maximum power point tracking(MPPT) control algorithms; and the third approach is to adopt solar tracking system to obtain maximum solar energy input from the sun. In this paper we use the solar tracking system for generation of electricity. In this paper light detector sensor senses the intensity of sun light and convert it into electricity which is directly proportional to intensity. Solar panel rotates according to sun position by rotating solar panel with the help of stepper motor and microcontroller. At present solar electric power generation systems are having fixed solar panels whose efficiency of generation is less. The aim of the paper is to introduce the solar tracking to the existing fixed solar panels, thus we are maintaining the constant maximum power output. Thus by using this tracking system we can increase the conversion efficiency of the solar electric power generation. For this purpose, we uses PIC microcontroller for sun tracking.

## 2. NEED OF SOLAR POWER SYSTEM

The increasing demand for energy, the continuous reduction in existing sources of fossil fuels and the growing concern regarding environment pollution, have pushed mankind to explore new technologies for the production of electrical energy using clean, renewable sources, such as solar energy, wind energy, etc. Among the nonconventional, renewable energy sources, solar energy affords great potential for conversion into electric power, able to ensure an important part of the electrical energy needs of the

planet. Solar energy is free, practically inexhaustible and involves no polluting residues or green gases emissions. International Journal of Engineering Research & Technology (IJERT) Vol. 2 Issue 2, February- 2013 ISSN: 2278-0181 www.ijert.org 1 IJERT

### 3. LITERATURE SURVEY

#### 3.1 History

Energy is the primary and most universal measure of all kinds of work by human beings and nature. Primarily, it is the gift of the nature to the mankind in various forms. The consumption of the energy is directly proportional to the progress of the mankind. With ever growing population, improvement in the living standard of the humanity, industrialization of the developing countries, the global demand for energy increases day by day. The primary source of energy is fossil fuel, however the finiteness of fossil fuel resources and large scale environmental degradation caused by their widespread use, particularly global warming, urban air pollution and acid rain, strongly suggests that harnessing of non-conventional, renewal and environmental friendly.

#### 3.2 Existing process

Electricity generation is the process of generating electric energy from other forms of energy. The fundamental principles of electricity generation were discovered during the 1820s and early 1830s by the British scientist Michael Faraday. His basic method is still used today. Electricity is generated by the movement of a loop of wire, or disc of copper between the poles of a magnet. Electricity is most often generated at a power station by electromechanical generators, primarily driven by heat engines fuelled by chemical combustion or nuclear fission but also by other means such as the kinetic energy of flowing water and wind. There are many other technologies that can be and are used to generate electricity such as solar photovoltaic and geothermal power. There are fundamental methods of transforming other forms of energy into electrical energy:

Using thermal power:

The direct conversion of temperature differences to electricity, as in thermocouples, thermopiles, and thermionic converters is done in this method. A

thermal power station is a power plant in which the prime mover is steam driven. Water is heated, turns into steam and spins a steam turbine which drives an electrical generator. After it passes through the turbine, the steam is condensed in a condenser and recycled to where it was heated; this is known as a Rankine cycle. The greatest variation in the design of thermal power stations is due to the different fuel sources. Some prefer to use the term energy center because such facilities convert forms of heat energy into electricity. Some thermal power plants also deliver heat energy for industrial purposes, for district heating, or for desalination of water as well as delivering electrical power. A large part of human CO<sub>2</sub> emissions comes from fossil fuelled thermal power plants; efforts to reduce these outputs are various and widespread.

Disadvantages:

Harnessing the power of it is difficult. It can cost a lot of money and requires further research. Waves can be big or small so you may not always be able to generate electricity. Not many people have tried to generate electricity this way yet so the equipment is expensive. Using Wind power: There are two primary physical principles by which energy can be extracted from the wind; these are through the creation of either lift or drag force (or through a combination of the two). Drag forces provide the most obvious means of propulsion, these being the forces felt by a person (or object) exposed to the wind. Lift forces are the most efficient means of propulsion but being more subtle than drag forces are not so well understood. Disadvantages: The strength of the wind is not constant and it varies from zero to storm force. This means that wind turbines do not produce the same amount of electricity all the time. Wind turbines are noisy. When wind turbines are being manufactured some pollution is produced. Therefore wind power does produce some pollution. Large wind farms are needed to provide entire communities with enough electricity.

Using Nuclear power:

The creation and acceleration of charged particles (examples: beta volatics or alpha particle emission). In a nuclear power station the uranium is first formed into pellets and then into long rods. The uranium rods are kept cool by submerging them in water. When

they are removed from the water a nuclear reaction takes place causing heat. The amount of heat required is controlled by raising and lowering the rods. If more heat is required the rods are raised further out of the water and if less is needed they lower further into it.

#### Disadvantages:

Nuclear power is a controversial method of producing electricity. Many people and environmental organisations are very concerned about the radioactive fuel it needs. There have been serious accidents with a small number of nuclear power stations. The accident at Chernobyl (Ukraine) in 1986, led to 30 people being killed and over 100,000 people being evacuated. There are serious questions to be answered regarding the storage of radioactive waste produced through the use of nuclear power. Storing and monitoring the radioactive waste material for thousands of years has a high cost.

#### Using solar power:

The transformation of light into electrical energy, as in solar cells is done in the photoelectric effect. Solar tracking allows more energy to be produced because the solar array is able to remain aligned to the sun. Maximizing power output from a solar system is desirable to increase efficiency. In order to maximize power output from the solar panels, one needs to keep the panels aligned with the sun. As such, a means of tracking the sun is required. This is a far more cost effective solution than purchasing additional solar panels. It has been estimated that the yield International Journal of Engineering Research & Technology (IJERT) Vol. 2 Issue 2, February-2013 ISSN: 2278-0181 www.ijert.org 2 IJERT from solar panels can be increased by 30 to 60 percent by utilizing a tracking system instead of a stationary array.

#### Advantages of solar power:

The energy and heat from the sun is free and unlimited. Solar power is non-polluting. Solar power usage does not emit any greenhouse gases or harmful waste. Solar power is perfect and saving for power generation in remote areas or where the cost of expansion utility grid is high. Solar power is versatile. It can be used for low-power purpose as

well as larger ones - from hand-held calculators, watches, and solar powered garden lights to water heaters, cars, buildings and satellites. Also due to simple construction and low maintenance cost solar energy systems are mainly used for generation purpose.

### 3. SOLAR TRACKING SYSTEM

#### 4.1 concept of solar tracking

A solar tracker is a device for orienting a day lighting reflector, solar photovoltaic panel or concentrating solar reflector or lens toward the sun. The sun's position in the sky varies both with the seasons and time of day as the sun moves across the sky. Solar powered equipment works best when pointed at or near the sun, so a solar tracker can increase the effectiveness of such equipment over any fixed position, at the cost of additional system complexity. A solar tracker is basically a device on to which solar panels are fitted which tracks the motion of the sun across the sky ensuring that the maximum amount of sunlight strikes the panels throughout the day. After finding the sunlight, the tracker will try to navigate through the path ensuring the best sunlight is detected. Electro optical control unit tracks the sun by a solar detecting device that is sensitive to solar radiance Photo sensors produce a signal relative to the sun light that falls on them. Changes according to the movement of the sun occur in the signals produced by photo sensors. These different signals, which reach the control system, are evaluated and the required instruction signal is sent to the motor, which moves the solar panel. The panel moves according to this control signal and the movement of the panel stops at the position where it directly faces the sun, when the signals from photo sensors reach the value. A solar tracker is an electro-mechanical system used on behalf of orienting a solar photovoltaic panel in the direction of the sun. It is used in many applications such as the transportation signalling, lighthouses, emergency phones installed in the highways, etc... Its main objective is to find the maximum sun radiations in order to get maximum charge for the batteries.

#### 4.2 tracker mount types

Solar trackers may be active or passive and may be single axis or dual axis. Single axis trackers usually use a polar mount for maximum solar efficiency.

Single axis trackers will usually have a manual elevation adjustment on a second axis which is adjusted on regular intervals throughout the year. Compared to a fixed amount, a single axis tracker increases annual output by approximately 30% and a dual axis tracker an additional 6%. There are different types of trackers, these are:

**Polar trackers:**

These trackers have one axis aligned to be roughly parallel to the axis of rotation of the earth around the north and south poles—hence the name polar. Single axis tracking is often used when combined with time-of-use metering, since strong afternoon performance is particularly desirable for grid-tied photovoltaic systems, as production at this time will match the peak demand time for summer season air-conditioning. A fixed system oriented to optimize this limited time performance will have a relatively low annual production. The polar axis should be angled towards due north, and the angle between this axis and the vertical should be equal to your latitude. Simple polar trackers with single axis tracking may also have an adjustment along a second axis: the angle of declination. This allows for angle the panel to face the sun when it is higher in the sky in the summer and to face it lower in the sky in the winter.

**Altitude-azimuth:**

A type of mounting that supports the weight of the solar tracker and allows it to move in two directions to locate a specific target. One axis of support is horizontal (called the altitude) and allows the telescope to move up and down. The other axis is vertical (called the azimuth) and allows the telescope to swing in a circle parallel to the ground. This makes it easy to position the telescope: swing it around in a circle and then lift it to the target. However, tracking an object as the Earth turns is more complicated. The telescope needs to be adjusted in both directions while tracking, which requires a computer to control the telescope.

**Active tracker:**

Active trackers use motors and gear trains to direct the tracker as commanded by a controller responding to the solar direction. Active two-axis trackers are also used to orient heliostats - movable mirrors that reflect sunlight toward the absorber of a central

power station. As each mirror in a large field will have an individual orientation these are controlled programmatically through a central computer system, which also allows the system to be shut down when necessary. Since the motors consume energy, one wants to use them only as necessary. So instead of a continuous motion, the heliostat is moved in discrete steps. Also, if the light is below some threshold there would not be enough power generated to warrant reorientation. This is also true when there is not enough difference in light level from one direction to another, such as when clouds are passing overhead. Consideration must be made to keep the tracker from wasting energy during cloudy periods.

**Passive tracker:**

Some works passive tracker head in Spring/Summer tilt position with panels on light blue rack pivoted to morning position against stop. Dark blue objects are hydraulic dampers. Passive trackers use a low boiling point compressed gas fluid that is driven to one side or the other to cause the tracker to move in response to an imbalance. As this is a International Journal of Engineering Research & Technology (IJERT) Vol. 2 Issue 2, February- 2013 ISSN: 2278-0181 www.ijert.org 3 IJERT non-precision orientation it is unsuitable for certain types of concentrating photovoltaic collectors but works fine for common PV panel types. These will have viscous dampers to prevent excessive motion in response to wind gusts. Reflectors are used to reflect early morning sunlight to "wake up" the panel and tilt it toward the sun, which can take nearly an hour. The time to do this can be greatly reduced by adding a self-releasing tie down that positions the panel slightly past the zenith and using the tie down in the evening. The term "passive tracker" is also used for photovoltaic modules that include a hologram behind stripes of photovoltaic cells. That way, sunlight passes through the transparent part of the module and reflects on the hologram. This allows sunlight to hit the cell from behind, thereby increasing the module's efficiency. Also, the module does not have to move since the hologram always reflects sunlight from the correct angle towards the cells.

**4.3 How solar energy is converted into current?**

Solar cells are systems that are composed of semiconductor materials and which convert solar

energy directly into current. The amount of electrical energy which will be obtained is directly proportional to the intensity of sun light that falls on the photovoltaic (PV) panel. When light falls on the device the light photons are absorbed by semiconducting material and electric charge carriers are generated. The relation between incident photon energy and frequency is where = Planck constant and = frequency. Silicon is the most abundant element available on the earth surface and mostly of the solar cells fabricated using them.

## 5. PROPOSED SYSTEM

### 5.1 Block diagram of system

Figure shows proposed block diagram of project. As shown in the figure, here day/night sensor which is LDR is used for detecting intensity of solar light. According to intensity of light solar panel rotate to get maximum intensity with the help of stepper motor and driver. LCD displays the status of load, and some information. During day time charging unit shall be started, battery level shall be monitored and charging controlled according to the battery voltage level. During night time charging shall be cut off. Load is operated depending on the electricity generated which is directly proportional to the intensity of sun light. Charging module used to charge a battery and Panel control unit used to connect and disconnect solar panel. The microcontroller is used such that it should have the in-built ADC. Here I prefer to use the PIC18F458 microcontroller. This microcontroller has the 8 analog channels with 10-bit digital output corresponding to the analog input.

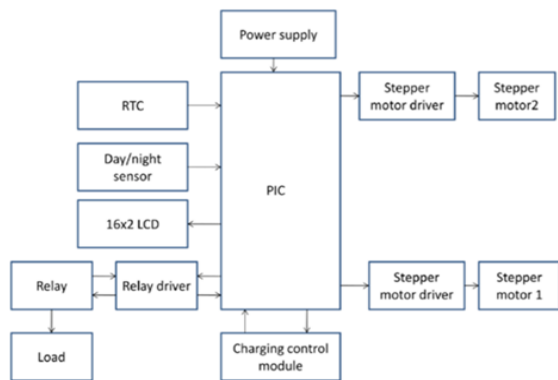

Figure 1: Block diagram of system

Power Supply:

We need the regulated 5 V output for the most of the IC's used in our system. In this paper power generated by sun light is used for IC's operation so does not need of external power supply.

Stepper Motor and Motor Driver:

Stepper motor is a digital actuator whose input is in the form of programmed energization of the stator windings and whose output is in the form of discrete angular rotation. In this project two stepper motors are used for the mounting the solar panel. Two stepper motors are mounting below the two ends of solar panel at the opposite site. Microcontroller cannot compatible with stepper motor so stepper motor driver used for compatibility. The stepper motor is used to rotate the solar panel accordingly where we obtain maximum voltage. Two stepper motors are used to put the panel at correct position.

LCD:

In this paper 16\*2 LCD is used for displaying status of load, battery health etc.

RTC:

This paper tracks sun continuously by sensing panel voltage and real time clock. IC PCF 8583 used for real time clocking. The PCF8583 is a clock and calendar chip, based on a 2048 bit static CMOS RAM organized as 256 words by 8 bits. Addresses and data are transferred serially via the two-line bidirectional I2C-bus. The built-in word address register is incremented automatically after each written or read data byte. Address pin A0 is used for programming the hardware address, allowing the connection of two devices to the bus without additional hardware.

Charging control module:

Charging module used to charge a battery and Panel control unit used to connect and disconnect solar panel. The charge controller's function is to regulate the power flowing from a photovoltaic panel into a rechargeable battery. It features is an equalize function for periodic overcharging, and automatic temperature compensation for better charging over a range of temperatures.

International Journal of Engineering

Research & Technology (IJERT) Vol. 2 Issue 2, February- 2013 ISSN: 2278-0181 www.ijert.org 4 IJERT The goal of the design was to make a charge controller with analog simplicity, high efficiency, and reliability. A medium power solar system can be built with a 12V solar panel up to 10 amps, the circuit, and a rechargeable battery. It works with lead acid, NiCD and NiMH batteries with ratings from less than one to several hundred amp-hours.

Day/night sensor:

Light detector sensor i.e LDR is used as day/night sensor. It consists of two cadmium sulphide (cds) photoconductive cells. The cell resistance falls with increasing light intensity. In this paper, it was desired for the output voltage to increase as the light intensity increases, so the photocell was placed in the top position.

Relay:

A relay is an electrical switch that opens and closes under the control of another electrical circuit. In the original form, the switch is operated by an electromagnet to open or close one or many sets of contacts. Because a relay is able to control an output circuit of higher power than the input circuit, it can be considered to be, in a broad sense, a form of an electrical amplifier.

Microcontroller:

It is the major part of the system. The microcontroller controls all the operations. The solar panel is aligned according to the intensity of sunlight under the control of the microcontroller.

### 5.2 Algorithm

1. Initially check the time on RTC. 2. If it is day time then check the position of sun. If there is no day time then not go to step 7. 3. Check for maximum intensity of sun if it less than maximum then rotate the solar panel with the help of stepper motors.
4. Start the charging of battery with the help of charging control module. 5. Store the electric energy into battery. 6. If battery charged up to maximum level then disconnect the connection with solar panel.
7. During night charging will be cut off. 8. Whenever required switch on the load with the help of relay. 9. Display the status of load on the LCD.

### 5.3 Advantages

1. The energy and heat from the sun is free and unlimited.
2. Solar power is non-polluting. Solar power usage does not emit any greenhouse gases or harmful waste.
3. Solar power is perfect and saving for power generation in remote areas or where the cost of expansion utility grid is high.
4. Solar power is versatile. It can be used for low-power purpose as well as larger ones - from hand-held calculators, watches, and solar powered garden lights to water heaters, cars, buildings and satellites.
5. Solar power system requires very little maintenance and last for many years.

### REFERENCES

- [1] Syamsiah Mashohor, Kharulmizam Samsudin, Amirullah M. Noor and Adi Razlan, A. Rahman, "Evaluation of Genetic Algorithm based Solar Tracking System for Photovoltaic Panels", ICSET, IEEE 2008.
- [2] Miguel Romero, Rafael Lemuz, Irene O. AyaquicaMartínez, Griselda Saldaña-González, "A Calibration Algorithm for Solar Tracking System", 10th Mexican International Conference on Artificial Intelligence, IEEE 2011.
- [3] A. Kassem, M. Hamad," A Microcontroller-Based MultiFunction Solar Tracking System", IEEE 2011.
- [4] A.K.Saxena, V. Dutta, "A versatile microprocessor-based controller for solar tracking", IEEE 1990.
- [5] Md. Tanvir Arafat Khan, S.M. Shahrear Tanzil, Rifat Rahman, S M Shafiu Alam," Design and Construction of an Automatic Solar Tracking System", 6th International Conference on Electrical and Computer Engineering ICECE, IEEE 2010.