

2D Plotter Machine

K.S.Prajhwal¹, K.S.Sabarish², S.Karan³, A.Subhashnan⁴, K.Ragunath⁵

^{1,2,3,4} SNS College of Engineering, Department of Mechanical Engineering, Coimbatore

⁵Asst.Prof., SNS College of Engineering, Department of Mechanical Engineering

Abstract- In this project, we have produced a 2-D plotter machine using an Arduino uno, CNC Shield and Stepper motors, in which the required picture can be drawn using certain software such as Arduino IDE and Processing. The main idea is to develop a 2-D plotter which can be taken to any place with ease. So the controller i.e.) CNC Shield controls the stepper motors and the servo motor to draw the required image. Even a laser engraver could be attached instead of a pen, so that the laser could engrave the image in required surface. This machine could draw both horizontally and vertically.

Index terms- 2D, Plotter, Arduino uno, Polargraph, Two-dimensional, XY Axis

I. INTRODUCTION

The main objective our team is to design a 2-D plotting machine which is portable and compact in size. The machine which is to be designed should be safe for all living beings and it also should be Eco-Friendly. This machine should be low in cost and this machine should be affordable for everyone. We also believe that our project will solve the problems or issues faced in the Lack of precision and scalability in Geographical Information System (GIS), and the Architectural, Engineering, and Construction (AEC) sectors. Because this machine could bring the precision in the plotting and it helps to reduce the scalability issues.

II. COMPONENTS AND THEIR DESCRIPTION

A. Hardware Components

Some of the hardware components that are used in the 2D Plotter machine are explained in detail below. The description and the type of the components that are used in this project are also explained in detail.

1. Arduino UNO

Arduino UNO is a microcontroller that controls the process of a machine. The UNO board is equipped

with sets of digital and analog input/output pins that may be connected to various expansion boards and other circuits. The Arduino is responsible for translating the commands sent over USB from the Polargraph application into electrical signals to the stepper motor controller. The Arduino and stepper motor controller are highly dependent upon one another.

2. CNC Shield V3

The CNC Shield V3 is an Arduino compatible board that turns your Arduino into a CNC controller. Using an opensource firmware it can control up to 4 Stepper motor using DRV8825 or A4988 stepper motor driver making it easy to get your CNC projects up and running in a few hours.

3. Stepper Motor

The stepper motor driver is responsible for actuating the motors as required, and electronically separating logic and power for safety and durability. The motors are responsible for moving the writing head by lengthening or shortening the amount of belt between the motor and writing head.

4. Servo Motor

A servo motor is an electrical device which can push or rotate an object with great precision. It is just made up of simple motor which run through servo mechanism. The servo motor is responsible for raising and lowering the pen off the page. It is connected to the stepper motor controller in our solution.

5. Timing Pulley with belt

Timing pulleys are specialized pulleys that have either teeth or pockets around the outside diameter of the pulley body. Timing teeth engage holes in the metal belt, while timing pockets engage drive lugs on a belt's inner circumference. These teeth or pockets are used only for timing, not for power transmission. This belt enables the stepper motor to control the movement and position of the pen or tool holder, as per the image fed into the software.

6. DC Power Supply

DC Adaptor is used to convert the AC Input supply from the plug point to the required DC power supply to the motor control board which is the CNC Shield.

B. Software requirements

Some of the software that are used in the 2D Plotter machine are mentioned below.

1. Arduino IDE

The Arduino Integrated Development Environment is a cross-platform application that is written in functions from C, C++, Java etc. This software enables us to load the program into the Arduino Board.

2. Processing (or)

Processing is a simple programming environment that was created to make it easier to develop visually oriented applications with an emphasis on animation and providing users with instant feedback through interaction.

3. Inkspace

Inkscape is a free and open-source vector graphics editor. This software can be used to create or edit vector graphics such as illustrations, diagrams, line arts, charts, logos, icons and complex paintings.

III. ASSEMBLY DIAGRAM

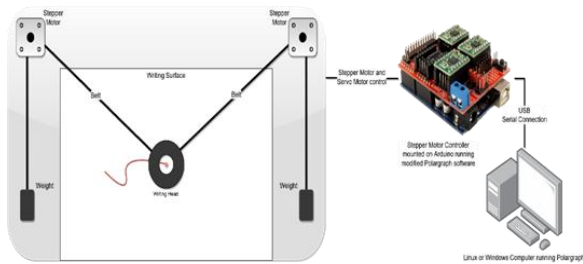

Fig 1: Assembly Diagram of the machine

IV. WORKING

2D plotter works on the principle of converting “Java Programming Code” into a visually oriented application or an environment, which turns the image into codes to control and run the 2D Plotter, to plot the image as fed into them. Processing is a simple programming environment that was created to make it easier to develop visually oriented applications with an emphasis on animation and providing users with instant feedback through interaction. A

Processing program is called a sketch. The idea is to make Java-style programming feel more like scripting, and adopt the process of scripting to quickly write code. This code develops an application, in which the required image to sketch is fed. So, the image fed is converted to codes and they are used to control the stepper motors and servo motors with the help of Arduino UNO and CNC Shield, to sketch the image.

V. WIRING DIAGRAM

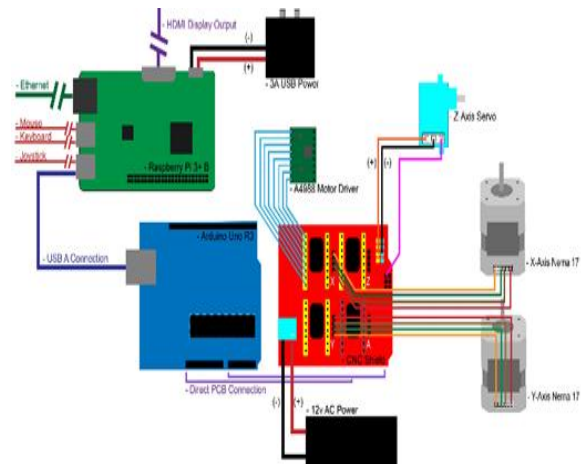

Fig 2: Wiring Diagram of the machine

VI. CONCLUSION

This innovation has made more desirable and economical. This project “2D PLOTTER” is designed with hope that it is very much economical, portable and quality based product for 2D Plotting. This project helped us to know the periodic steps in completing a project work, and enabled us to understand a lot more about automation and coding.

VII. FUTURE SCOPE

Instead of using Computer, a small Raspberry PI module would be attached, to make it more compact. An application is planned to be developed for mobile and other platforms, so that we could able feed the image through that application. And that application would enable the sketching with the help of “IOT”. We have also planned to give this device the ML & AI ability, to store the images fed and suggest the images based on the images that is fed. This can be achieved through “Python” language.

REFERENCES

- [1] T. Amano, "XY Plotter for producing diagrams from computer information," ed: Google Patents 1972
- [2] G. H. Joseph, "Xy plotter," ed: Google Patents, 1969.
- [3] G. H. Joseph and D. J. Logan, "Xy plotter," ed: Google Patents, 1966.
- [4] M. Sakamoto, R. Magumo, T. Ishihara, and T. Kobari, "XY plotter for non-perforated paper," ed: Google Patents 1990.
- [5] J. Yeiser, "Xy plotter," ed: Google Patents, 1973.
- [6] R. Krishnan, "Selection criteria for servo motor drives," Industry Applications, IEEE Transactions on, pp. 270-275, 1987.
- [7] R. D. Bloom, J. V. Gac, and E. T. Kozol, "Programmable servo motor speed control apparatus," ed: Google Patents, 1987.
- [8] H.-K. Park, S.-S. Kim, J.-M. Park, T.-Y. Cho, and D. Hong, "Dynamics of dual-drive servo mechanism," in Industrial Economics, 2001. Proceedings. ISIE 2001. IEEE International Symposium pp.1996-2000.
- [9] M. Iri, K. Murota, and S. Matsui, "An approximate solution for the problem of optimizing the plotter pen movement," in System Modelling and Optimization, ed: Springer, 1982, pp. 572-580.
- [10] G. Ghiani, D. Laganà, and R. Musmanno, "A constructive heuristic for the undirected rural postman problem," Computers and Operational Research, vol. 33, pp. 3450-3457, 2006.
- [11] S.-J. Shin, S.-H. Suh, and I. Stroud, "Reincarnation of G-code based part programs into STEP-NC for turning applications," Computer-Aided Design, vol. 39, pp. 1-16, 2007.
- [12] S. Gordon and M. T. Hillery, "Development of a high-speed CNC cutting machine using linear motors," Journal of Materials Processing Technology, vol. 166, pp. 321-329, 2005.
- [13] D. Moreton and R. Durnford, "Three-dimensional tool compensation for a threeaxis turning centre," The International Journal of Advanced Manufacturing Technology, vol. 15, pp. 649-654, 1999.
- [14] P. Kumar and P. Kumar, "Arduino Based Wireless Intrusion Detection Using IR Sensor and GSM," International Journal of Computer Science and Mobile Computing, 2 (5), pp. 417-424, 2013.
- [15] B. G. Schultz and F. T. van Vugt, "Tap Arduino: An Arduino microcontroller for low-latency auditory feedback in sensorimotor synchronization experiments," Behavior research methods, pp. 1-17, 2015.
- [16] J.-D. Warren, J. Adams, and H. Molle, Arduino for Robotics: Springer, 2011.
- [17] Y. A. Badamasi, "The working principle of an Arduino," in Electronics, Computer and Computation (ICECCO), 2014 11th International Conference on, 2014, pp. 1- 4.
- [18] S. Di Prima, "Automated single ring infiltrometer with a low-cost microcontroller circuit," Computers and Electronics in Agriculture, vol. 118, pp. 390-395, 2015.
- [19] Van Sevc'ik. A Low-cost Plotter Controlled by FITkit.(2015) Project for Faculty of Information Technology, Brno University of Technology.
- [20] Then kit sen. Virtual touchscreen based xy plotter system. (2012/2013) Declaration of Thesis / Undergraduate Project Paper. Faculty of Electrical Engineering Universiti Teknologi Malaysia JUNE 2013.