

Harmonics Detection and Measurement in Power System

Ms. Sritika Shadev Haldar¹, Mr. Rushikesh kishore Zagade², Mr. Digvijay Popat Pawar³, Ms. Sanjana Macchindra Shete⁴, Prof. Pranita chavan⁵

^{1,2,3,4} UG Student, Department of Electrical Engineering, Pillai HOC college of Engineering and Technology, Rasayani, Maharashtra, India

⁵ Assistant Professor, Department of Electrical Engineering, Pillai HOC college of Engineering and Technology, Rasayani, Maharashtra, India

Abstract- In the present decade usage of Nonlinear loads and power electronic device in the industry sector has been increasing. Due to this the harmonics in the system get affected more and it gets result in the nonlinear electric loads. Harmonics are determined to have tremendous effects on power system Equipment including Induction motor, Transformer, Conductors, Capacitor banks, Switchgear, and Protective relay. The count of harmonics producing loads has been having the drastic effect over the years. Now it has been became increasingly necessary to detect them by making changes to a system installation. Aiming towards the Improvement of Power Factor and Elimination of Harmonics induced in the system due to non-linear loads. This method helps to improve power factor and eliminate harmonics, so the power fed to the loads will be of better quality. This will not only reduce the penalization over consumers but also lead to run the load to their maximum efficiency.

Further, the circuit of PF correction & detection similarly the Harmonics measurement and correction simulations are presented over Proteus Software. This tool helps to carry out trial and error method of the circuits. The calculated values will be fed to the Controller circuits which carry out programmed operations to get the desired outputs which are displayed over the LCD.

Index terms- Nonlinear loads, Harmonic currents, Power Distribution system, Voltage distortion, Power Signal Quality, Harmonic Distortion, Power supply Quality, Harmonic Analysis, Total harmonic distortion (THD), Fast Fourier Transform (FFT).

1. INTRODUCTION

Every industry needs to implement power factor corrector & Harmonic Compensator to limit power wastage and to avoid penalty due to the same. But the same technique should be there for domestic level with small load in the house. In this system we

proposed the technique for the proper utilization of the sources available with the input at the home level. One of the most dominating sources available is mains supply from the MSEB and primary backup is Inverter. As the Technology is increasing day by day it should tends to improve, the extreme use of power electronics equipment in power system arises and then the harmonics comes in the system operation picture which cause the negative impacts on power system and trouble it's working. The power quality which defines that it is a set of electrical boundaries allowing a device to function in its intended manner with no significant loss of performance or life expectancy. Various methods and techniques were used to improve the power quality. Harmonics are voltage or current with frequencies which are integral multiplies of the fundamental power frequency. Harmonic current is one of the main concepts which affect the quality power and they are supplied by the nonlinear equipment, which affect the desired linear system. Common risk of harmonics include excessive heat in the system, tripping of the branch circuit breaker and rapidly increasing maintenance cost, Fire hazard. The harmonic component in an Ac power system is nothing but the sinusoidal components of a periodic waveform which has a frequency of an integer multiple of the fundamental of the system.

It can be given as:-

$$F_h = n * \text{fundamental frequency.}$$

Where f_h = Harmonic order, n = Integer. The frequency is either 50Hz or 60Hz.

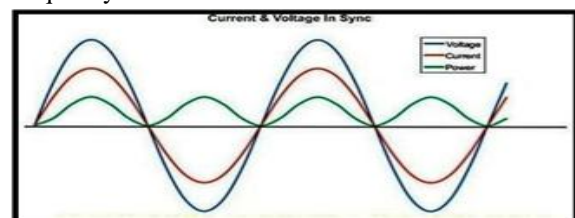

Fig 1. Current, voltage and power waveform.

Harmonic analysis is one of the great issues for maintaining good quality power system. Hence a lot of algorithms have been proposed on harmonic analysis; among them Fast Fourier Transform (FFT) is the most widely used algorithm. Fast Fourier Transform (FFT) is a component algorithm used to determine the Discrete Fourier Transform (DFT). For determining these harmonics which are relatively stationary compared to other power quality disturbances, the signals provided should be from the time domain to the frequency domain. This method is done by means of Discrete Fourier Transform (DFT). This paper focus on the implementation of 230v, 50Hz power supply harmonic analysis by using Fast Fourier Transform (FFT) algorithm.

1.1 CLASSIFICATION OF HARMONICS:-

Harmonics which are nothing but distorted waveform have two types namely voltage and current harmonics. The orders of harmonic and symmetrical components these are of two concepts which are used commonly to describe harmonics. Table shows harmonic order and their sequence as follows.

Name	F	2nd	3rd	4th	5th	6th
Frequency	50	100	150	200	250	300
Sequence	+	-	0	+	-	0

Fig 1.1 Table of harmonic order

In the present scenario, odd harmonic are the characteristics harmonic components in the power system. Waveforms that are symmetrical to the time axis are represented by odd harmonics. In the case of even harmonics they can only rise from waveforms that are not symmetrical to the axis.

2. PROPOSED CONTROL SCHEME

The microcontroller is the heart of the Automatic power factor correction unit. It processes the algorithms which are specified by the user to ensure the variation in the power factor in specifying limit and maintain power quality. The current transformer and voltage transformer are used to get the current and voltage signals which are inputs to the microcontroller. This automatic power factor correction unit detects the phase lag between the voltage and current waveform by using zero crossing detectors to determine the existing power factor. To

bring it to unity, it is required to connect capacitor bank with the system. The number of capacitors that is to be connected for compensation is determined by the algorithms in microcontroller. When the power factor is not near to unity then the microcontroller sends the signal to switching unit which will switch the number of capacitors that is Demanded from the capacitor bank and connect it to the system with the help of relay. The relay driver is used for interface between the microcontroller and the capacitor banks.

3. REQUIRIMENT ANALYSIS

3.1 BLOCK DIAGRAM:-

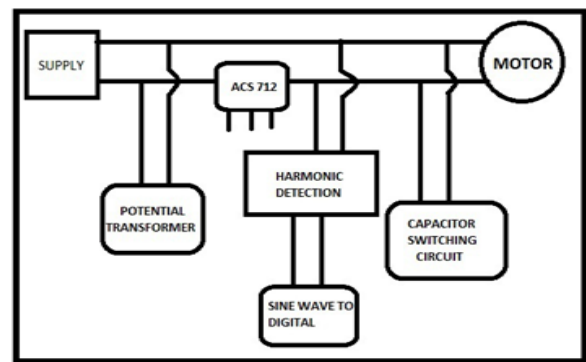

Fig 3.1 Block Diagram of overall circuit.

This is the overall block diagram of the system. In this we can see the Motor as Load fed from supply. In between these Current sensor (ACS 712) and Potential Transformer are connected. As motor is inductive in nature so the PF decreases and for compensation purpose Capacitor Switching bank is connected near to motor.

Due to Non-linear loads in the system, harmonic components increase in circuit as it has adverse effect over the supply system and Load. In this block diagram we can also see the harmonic detection circuit connected across the Motor.

3.2 CIRCUIT DIAGRAM:-

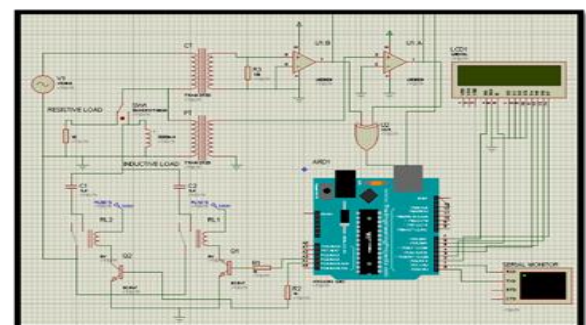

Fig 3.2 Power factor calculation and corrector circuit. The above figure shows the calculation and correction part of power factor for the smart meter. Firstly the supply fed to CT and PT, the output from CT and PT are given to the zero crossing Detector Circuit (ZCD UA741 IC), whose output is given to the XOR (7468 IC). The XOR IC process the output from comparator/ZCD and feeds to the controller circuit. Further the controller processes the according to program operations are fed to it.

The Controller (ATMEGA 328P) is connected to LCD and Relay Circuit. The Digital pins which are programed as output pins are connected to the LCD circuit where the output is displayed. Similarly the controller's Analog pins which stated as output pins are connected to Relay circuit (ULN2003A). This relay circuit is fed firing signals from the controller from its Analog pins, which are given to the SCR which completes the relay circuit and the capacitors comes in the circuit for the compensation purpose.

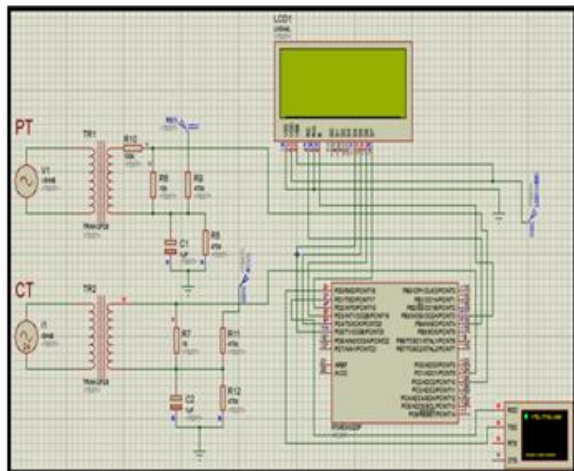

Fig 3.3 Harmonic circuit over proteus

Current harmonics measurements are simulated by using the proteus software, harmonic meter circuit which is designed using arduino micro controller. The harmonic meter circuit works on the simulated system voltage and transformer (TR2) to supply the current. Arduino microcontroller is programmed to display the 3rd order individual harmonic current or voltage. Then the current and power factor unit is been displayed in the Liquid Crystal Display (LCD). In addition to that there are two more resistor components respectively worth with 100k and 10k as a voltage divider of 2.5v DC to arduino. The TR2 output is connected to the system of two 470k ohm resistor components as a current analogue input used

as the bias current regulator. The 15 ohm resistor component used to serve the load and the 10uf capacitor component is used to pass the high frequency components by reducing the impedance. The harmonic meter circuit is indicated in the above shown figure.

Harmonic is a very basic property of power quality so it has become a necessary thing to measure these harmonics. Instead of using a traditional measurement device a new method is used to detect and measure harmonics present in the system. The device consists of analog to digital converter, FFT unit and LCD display unit.

3.3 POWER SUPPLY DESCRIPTION

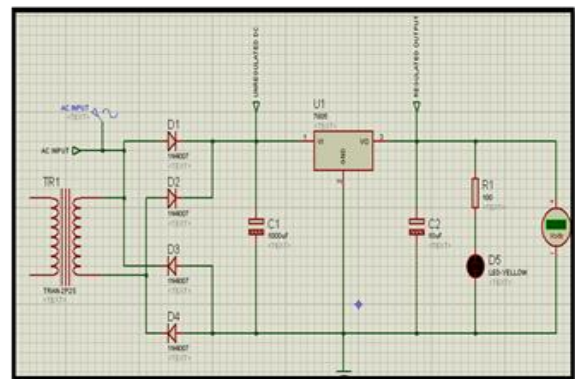

Fig 4 Power supply circuit

The input supply of 230v, 50Hz AC is applied across the primary of a step-down transform. The output is taken from the secondary coil of the supply system and it is applied across the rectifier section. The rectifier section is in the form of Bridge Rectifier, Formed by arranging four diodes (IN4007) in a bridge patterns. Diodes are used for the rectification purpose. The output which is obtained from the bridge circuit is not in the form of pure DC and an AC component is also present in the form of a ripple. In order to reduce this ripple an electrolytic capacitor of (1000uf) is connected at the output of the diode bridge circuit. The cathode terminals of the Diode D2 and D3 are connected to the positive (+ve) terminal of the capacitor and also connected to the input of the IC regulator (7805). The voltage regulators which are used in this system is to obtained the fixed voltages as per the requirement. The output from the IC regulator is given to the LED through a resistor, when the output of the IC is given to the LED it gets forward bias and hence the LED starts glowing.

4. SOURCES OF HARMONIC

4.1 Static compensators:-

If the source of power in the system is more fluctuating, Static compensators are used in the end of the transmission lines or else in the nearest sources of the fluctuating power. Static compensators are used to manage the voltages in the power system. Reactors of the system which are controlled by the thyristor will produce near about 1% of the 11th harmonic current in the power system.

4.2 Power converters:-

The system rectifier gives higher inductance on the DC side as compared to the AC side. The DC current which is provided to the system acts almost constant and then the converter starts acting as a harmonic voltage source on the DC side where as the harmonic current source act on the ac side in the power system.

4.3 Transformers:-

Due to occurrence of saturation and Hysteresis characteristics, a minor amount of harmonics current will get produce by the transformer when they are in steady state. Drastically high level of harmonics will get produce, which is amount ably 60% of the rated transformer current.

4.4 Rotating machine:-

Harmonic current produced in the rotating machine is due to asymmetries in the winding pattern. Harmonics in the system is increasing because of the resultant magneto motive force in the machine. Harmonic currents are produced due to magnetic saturation in the machine.

4.5 Electric Arc Furnance:-

As the arc feed material, in the system changes the harmonics rise up and their value cannot be predicted quickly. The electric arc furnances load gives most awful distortions and the result of melting with the moving electrode and molten material.

4.6 Switched mode power supplies (SMPS):-

Now a day the electronic device mostly contain switched mode power supplies. Switched mode power supply regulates AC or DC input voltage. SMPS unit draws current pulses containing large

amount of harmonic of the third and above higher order harmonics.

5. METHODS OF IMPROVEMENT

5.1 Capacitors:-

Improvement of power factor means reducing the phase difference between voltage and current. Mostly the loads used are inductive in nature, they require some amount of reactive power from them to function. This type of reactive power is supplied through the capacitor or bank of capacitors installed parallel to the load. Mostly they act as a source of reactive power load and thus less reactive power flows through the line system. Basically it tends to reduce the phase difference between the voltage and current.

5.2 Synchronous condenser:-

The 3 phase synchronous motor with no load attached to its shaft. This type of motor has the characteristics of operating under any power factor such as leading, lagging, or unity depending upon the excitation. For the inductive loads system synchronous condenser is connected towards the load side and its over excited. It makes to behave it like a capacitor. Hence it draws the lagging current from the supply system or supplies the reactive power.

5.3 Phase Advancer:-

To improve the power factor of induction motor phase advancer is used. Phase advancer is also known as an AC exciter. They are mounted on the shaft of the motor system and are directly connected in the rotor circuit of the motor. It improves the power factor by giving the exciting ampere turns to produce required flux at slip frequency. More over further if the situated ampere turns increased, it can be made to operate at leading power factor.

5.4 Capacitors Designed to handle the harmonic distortion:-

All the power survey capacitors are made to handle harmonic current, hence it also offer the capacitors custom designed for system with high harmonic distortion. If the desired system have the harmonic reach application, hence our high harmonic capacitors will provide a more strong construction

compared to using standard capacitors in the same application system.

5.5 Passive Harmonic Filter:-

We manufacture a passive harmonic filter the filter which creates an "anti-harmonic" at the desire selected harmonic frequencies that drastically reduce the harmonic current at that frequency. This type of filter can be induced in your capacitor bank solution.

5.6 Active Harmonic Filter:-

We produce an active harmonic filter (AHF) that automatically identified the existence of harmonic currents across the frequency spectrum and creates "anti-currents" to reduce the harmonics at acceptable levels. As like the passive filters, they does not required a pre study of the circuit harmonic current to effect the design of the filter.

6. EXPERIMENTAL INVESTIGATION

6.1 Overall implemented prototype

This is our Power Factor & harmonics Analysis and Corrector Model. In this Power Factor is being compensated, when measured power factor value goes below the set value, with the help of Electrolytic Capacitors. This method helps to improve power factor and eliminate harmonics, so the power fed to the loads will be of better quality. This will not only reduce the penalization over consumers but also lead to run the load to their maximum efficiency.

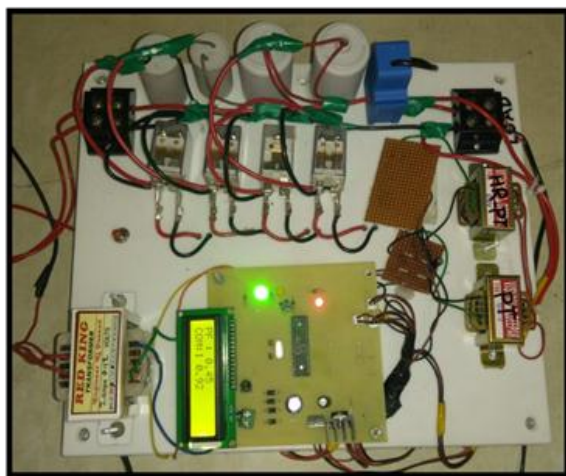

Fig 6.1 Overall project circuit

6.2 Power compensated result



Fig 6.2 Power factor result

6.3 Harmonic Result

Showing Harmonics Amplitude & THD Before Compensation



Compensators are High



Fig 6.3 Harmonic before compensation

Showing Harmonics Amplitude & THD After Compensation



Compensators are Low



Fig 6.4 Harmonic after compensation

7. CONCLUSION

From this Project Report, it is observed, analyzed and concluded that:

- Improvement of power factor is necessary in both consumer and supplier point of view. In industries where power consumed by the load is low, high rating of equipment are required.
- By considering the above said system we can conclude that this system will definitely help for proper distribution of renewable and non-renewable sources along with the power factor correction to make the power uses more efficiently, nothing but limiting losses which again add up in main power flow.
- This Report work is an attempt to design and implement the APFC system using microcontroller. Microcontroller continuously monitors the power factor and then according to the lagging and leading power factor it takes the control action.
- Hence the APFC units correct the power factor above a decided value by switching the appropriate no of capacitors from the capacitor bank .In non-linear loads we use inductors, filters, valley-fill circuit etc. to suppress harmonics as they cause the current waveform to be distorted.
- From the Report we have managed arduino to show the measurement of harmonic content of 3rd order current, voltage, current and power factor displayed by LCD.
- Proposed system uses FFT Algorithm for measuring total harmonic distortion.
- The various harmonic mitigation strategies adopted in the last three decades have been reviewed. Based on this survey a new methodology to control harmonic distortion in power system is introduced. In the proposed method harmonics get detected using Arduino.

The benefits of the proposed optimization method are:

1. Detection of harmonics in easier way
2. Correct measurement of harmonics and THD.

- [1] International Journal of Engineering and Innovative Technology (IJEIT) Volume 3, Issue 4, October 2013 272 Power Factor Correction Using PIC Microcontroller.
- [2] Jenna Joy, Amalraj P.M, Aswin Raghunath, Nidheesh M.N., Vinu Joseph, Asst. Prof, Dept. of EEE, “Harmonic Analysis of 230 V AC Power Supply Using LPC2138 Microcontroller” Mar Athanasius College of Engineering, Kothamangalam. UG Student, Dept. of EEE, Mar Athanasius College of Engineering, Kothamangalam.
- [3] Fast Fourier Transform Algorithms with applications August 2008 Todd Mateer Swiss Federal Institute of Technology Zurich.
- [4] Fast Fourier Transform Numerical Analysis Seminar Stefan Warner.
- [5] Harmonic Detection using Microcontroller Jaipreet Kaur, Deepak Asati International Journal of Computer Technology and Electronics Engineering (IJCTEE).

REFERENCES