

A Review on Solar Based Induction Heater

Ms. Shweta Laxman Hajare¹, Mr. Narendra Navinkumar Jakka², Ms. Dipali Namdev Shinde³, Ms. Kajal Jaiprakash Rajput⁴, Prof. R. D. More⁵

^{1,2,3,4} UG Student, Department. of Electrical Engineering, Pillai HOC college of Engineering and Technology, Rasayani, , Maharashtra, 410207, India.

⁵Assistant Professor, Department. of Electrical Engineering, Pillai HOC college of Engineering and Technology, Rasayani, , Maharashtra, 410207, India

Abstract- Induction heating is widely used nowadays because of its high efficiency and clean operation. It is safe to use. It is derived from the principle of electromagnetic induction. The solar energy is the main source used to produce heat. The aim of the project is to build an induction heater which will run on the solar energy.

Index terms- Solar energy, Half Bridge, Induction heater, Solar energy based Induction heater, Induction Principle, Environment friendly

1. INTRODUCTION

Solar Energy is a very clean of source of energy available as well as solar is a good source of energy. Solar Energy is a very clean of source of energy available as The continuous exhaustion of conventional energy sources and their environmental impacts have created an interest in choosing renewable energy sources such as solar photovoltaic, and wind energy, producer gas and biomass sources to power induction heating system well as solar is a good source of energy. The project is based on the induction heating principle and implementation of induction heater using renewable source of energy as the Primary source of supply Induction heating is the process of heating electrically ferromagnetic (conductive) materials by a process called electromagnetic induction.

Induction heating is widely used nowadays in all the domestic appliances because the cleanness is high, efficiency is high, safety is very high, and cost is low advanced power semiconductors and high performance. Induction heating is commonly used in industries for melting, hardening and brazing. High efficiency comes with the idea that all the magnetic

field created between the coil and the pan is at least 80% transferred to the coil.

2. DESIGN OF THE SYSTEM

Induction heating is the process of heating electrically ferromagnetic (conductive) materials by a process called electromagnetic induction. The design includes an induction coil which is supplied from solar panel. The battery charging and power control unit to control the output power at varying operating frequency chosen by the cooking setting.

2.1 Solar Energy

The solar energy gives the supply directly to the converter. The voltage is converted to direct current supply by the help of DC to DC converter. Battery charge control circuit is used in both simulation and practical as it is a standard voltage.

2.2 Solar

The solar is the primary source of supply for the cooker. Solar is made up of photovoltaic cells that converter solar energy into electrical energy in the form of direct current.

2.3 DC to DC Converter

The converter regulates the unregulated DC supply of the solar panel. The smooth DC supply is necessary to be dc regulated for the charging unit for the charging process and to supply the inverter with smooth supply. 48 Volt DC to 115 Volt DC converters can be used in the simulation while the practical ratings for the 3 power levels were taken as 48 Volt DC to 65 Volt DC. The practical results shown were just a demo to investigate the possibilities of the implementation of the project. The

simulation ratings are the one that will be used in the second phase of the project.

2.4 Battery charging circuit

The battery storage is for energy accumulation that has electrochemical cells. Portable size rechargeable batteries are used in order to maintain load levelling. The charger controller circuit controls the charging and the discharging of the battery level to extend the life of the battery.

2.5 Control circuit

The control circuit is designed by using the process controls such as charging, monitoring, displaying and auto switching. The programming algorithm and flow chart for the control unit is shown in fig. 6. The circuit controls the power levels according to the user selection input.

2.6 Induction coil

Induction cooking is a principle which works on the principle of electromagnetic induction by heating the cooking vessel directly. The cooking vessel is a ferromagnetic material of which is capable of allowing Eddy currents to flow and produce heat on the material.

3. REQUIREMENT ANALYSIS

3.1 BLOCK DIAGRAM:-

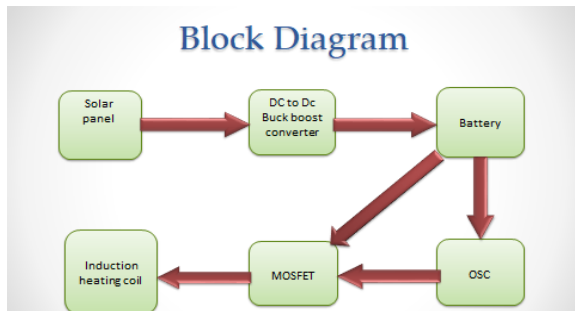
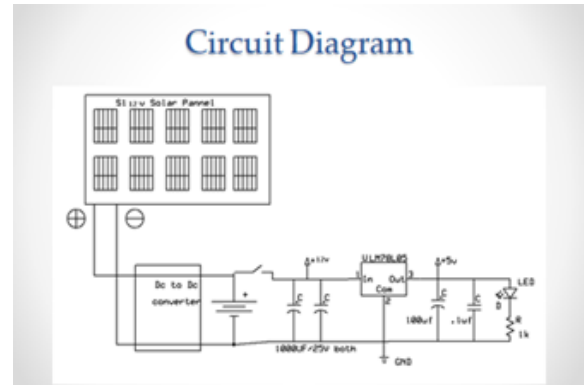

Fig 3.1 Block Diagram of overall circuit.

This is the overall block diagram of the system. In this we can see the system is connected to the solar system and the output of solar system is fed to dc to dc converter because the output of solar energy is constant, then the output is connected to the battery where the charge is stored and then given to the osc and mosfet and at last it reaches to the induction coil where we can easily sense the heating effect

3.2 CIRCUIT DIAGRAM



The above shown diagram is the circuit diagram of the whole circuit. The clear representation is given of all the connections done in the project along with the solar panel.

4. DC TO DC BUCK BOOST CONVERTER

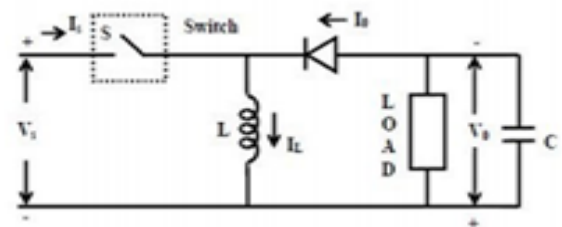

The operation of the buck-boost converter can be easily understood in terms of the inductor's "reluctance" in order to allow the rapid change in electric current. From the initial state where the charge is zero and the switch is in open state, the electric current through the inductor is zero. When the switch is first closed, the blocking diode tries to prevent the current from flowing into the right hand side of the circuit, so it must all flow through the inductor.

5. VOLTAGE REGULATOR LM7805

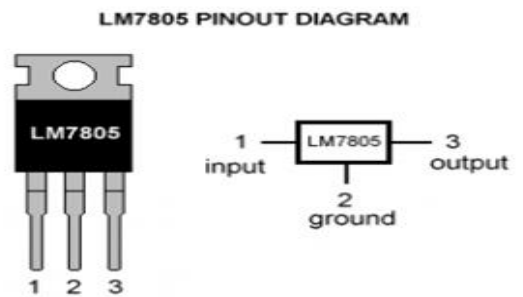

A voltage regulator IC always maintains the output of voltage at a constant value of voltage 7805 IC, A member of 78xx series of fixed linear voltage regulators is always used to maintain the fluctuations; it is a well-known voltage regulator integrated circuit (IC). The xx in 78xx tells us the output voltage it is going to provide. 7805 IC will provide the +5 volts regulated power supply with the provision to add a heat sink.

[2] Bandile I. sibiya, Dr. chitra venugopal, "Solar powered induction cooking system" Energy procedia, vol-117, pp.145-156,(2017)

6. ADVANTAGES

- Natural gas crisis will be mitigated.
- Deforestation will start to fall drastically.
- Environmental pollution will be reduced.
- Clean operation can be achieved.
- The operation is simple.
- It has high Efficiency.

7. DISADVANTAGES

- Cooking has to be done during daytime because at night time there will be no solar energy.
- Initial cost of this project is high, as the apparatus is costly.
- If cooking has to be performed at night time, then additional costs will have to be added for battery storage.
- It is not completely reliable as solar energy is not constant.

8. CONCLUSION

- The system becomes environmental friendly as it is using clean free energy from sun.
- The operation is simple of a solar based induction heater as compared to a existing Solar heater.
- The designed is a project where by the batteries are charged from solar and grid. The grid charging is selected when the solar power is not available.

REFERENCES

[1] Design and Simulation of a Solar Electricity Based Induction Cooker using Quasi Resonant Topology Bikal Adhikari 1, Jagan Nath Shrestha 2, Shree Raj Shakya 3 Proceedings of IOE Graduate Conference, 2016 pp. 1–11