

SOLAR DRYER USING SPARE CAPACITY OF SOLAR PUMPS POWER

Dileep kumar B.R.¹, Dheeraj D², Chethan M.³, Madhu B⁴, Professor Varsha V⁵

¹²³⁴students from a Department of Electrical and Electronics Engineering, VVIET, Mysore

⁵Assistant professor Department of Electrical and Electronics Engineering, VVIET, Mysore

Abstract- This paper presents an renewable energy sources of solar powered crop dryer which consists of a small fan, tunnel dryer and solar air heater to dry crops like fruits, vegetables, medical plants etc. These systems generates hot air to the atmosphere and dry the crops which is displayed on LCD display with the help of ATMEGA-328 microcontroller. Now-a day's renewable energy sources like solar are getting productive. The solar dryer was successfully tested in Greece, Yugoslavia, Egypt, Ethiopia and Saudi Arabia drying grapes, dates, onions, peppers and several medicinal plants. Compared to traditional sun drying methods, the use of the solar dryer reduces drying time significantly and prevents mass losses.

I. INTRODUCTION

In renewable energy resources solar energy is expanding its importance in daily life. This projects gives the design and explanation about the microcontroller based crop system as there are huge amount of energy is produced by the sun. The multipurpose solar crop dryer is invented to dry many agricultural things like fruits, vegetables, medical plants etc .The solar crop dryer consists of a small fan, solar air heater and a tunnel dryer hence it can be generated in small scale industries for farmers help with a less price too. Due to low investment required farmer can easily use these to dry about 1000kgs of fruits and vegetable in developing countries for better storage. As the primary source is the fossil fuel it is not harmful for the environment. As conventional energy sources are depleting solar energy and wind energy usages are become need of the day.

II. RELATED WORK

The solar panel of maximum power is operated, solar panel cannot be given directly to the dryer hence it is given to the MPPT or charge controller to provide

maximum power as irradiation and temp/cell changes the battery of suitable specification is usually uses the sealed smf batteries is given to the inverters, inverter produces the AC power and heat the coil to produce hot air in the field to blow in the atmosphere to dry the crops as soon as possible. The LCD is interfaced with the microcontroller for programming purpose. The battery charger is connected to the microcontroller to display on LCD that the battery is getting charged. The 5V power supply is given to the microcontroller and the LCD

III. SYSTEM OVERVIEW

Hardware Required

1. Solar panel

A PV module is an assembly photo-voltaic cell mounted in a framework for installation. Photo-voltaic cells use sunlight as a source of energy and generate direct current electricity. A collection of PV modules is called a PV Panel, and a system of Panels is an Array.

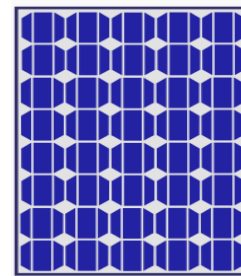

FIGURE: Solar panel

2. Charge controller

A charge controller, charge regulator or battery regulator limits the rate at which electric current is added to or drawn from electric batteries. It prevents overcharging and may protect against

overvoltage, which can reduce battery life or lifespan and may pose safety sake.



Figure: Charge controller

3. Battery



Figure: Battery

A battery is a device consisting of one or more electrochemical cells with external connections for powering electrical devices such as flashlights, mobile phones, and electric cars. When a battery is supplying electric power, its positive terminal is the cathode and its negative terminal is the anode.

4. ATmega328p

The Arduino Uno is a microcontroller board based on the atmega328. It has 14 digital input/output pins (of which can be used as PWM outputs), 6 analog inputs, a 16 MHz ceramic resonator, a USB connection, a power jack, an ICSP header, and a reset button. It contains everything for the microcontroller.

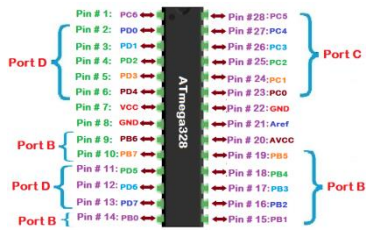

Figure:

ATmega 328p

5. Heating element



Figure: Heating coil

A heating element converts electrical energy into heat through the process of Joule heating. Electric current through the element encounters resistance, resulting in heating of the element. Unlike the Peltier effect, this process is independent of the direction of current.

6. Temperature sensor

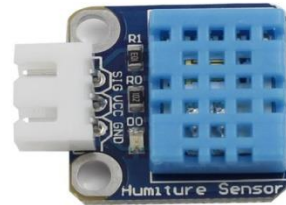
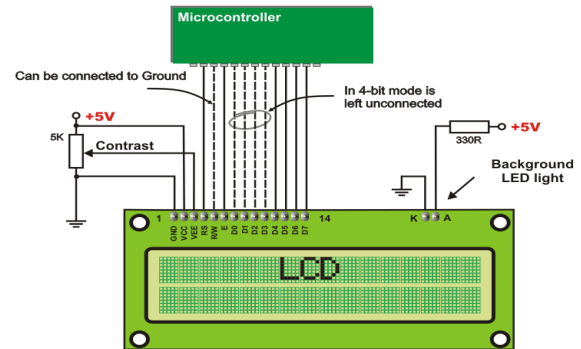

Figure: DHT11

The digital temperature and humidity sensor DHT11 is a composite sensor that contains a calibrated digital signal output of temperature and humidity.

7. 16*2 LCD



To send any facility from table 2 to the LCD, make pin RS=0.

For data, make RS=1. Then sends a high-to-low pulse to the E pin to enable the internal latch of the LCD.

IV. METHODOLOGY

Solar panel has V_{oc} and I_{sc} that is open circuit voltage and short circuit current which on testing with respect to the cell temperature gives as per the manufactures spec for charging a 12v 7.5ah DC smf battery a panel of 20v V_{oc} and 1.5amps of short circuit current to deliver a maximum current of 750ma which approximately charges battery for 12 to 14 hours the panel is connected to charge controller to maintain the maximum current through the day because as the sun position changes the cell/temperature changes hence the power delivered

to the controller will vary at the input but at the output it doesn't vary it will be maintained constant This constant power charges the battery constantly, the battery is used power the inverter Since it takes the ac current to heat the coil, the coil after heating, radiates the heat waves this heat is monitored using temperature sensor and the sensor values are sent to the input pin of microcontroller and the status is displayed in the LCD after reaching to a certain high temperature the arduino initiates the relay to trip and the blows gets turned on and the blower blow the hot air to the field.

Block diagram

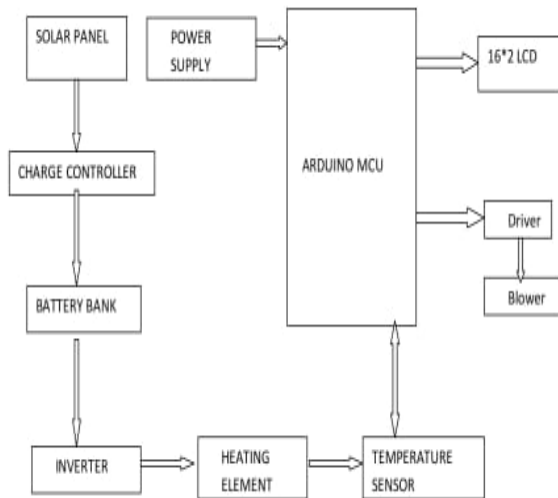

Flow chart

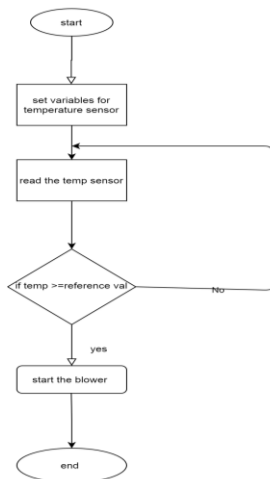

V. RESULT

Thus we can see that with the help of this system we are able to dry the crops like fruits, vegetables and medical plants in the atmosphere easily.

The solar crop dryer consists of a small fan, solar air heater and a tunnel dryer.



Figure: Solar crop dryer

VI. CONCLUSION

The wet crops are easily harmed hence method to save them is drying the crop is not that easy to the farm land it requires a high end technical work the project proposes the easy and economical way of drying the crop it not only dries the farm land but also provides the energy saving technique since it uses solar power to charge.

VII. ACKNOWLEDGMENT

We would like to give our sincere gratitude to my guide Mrs. Varshitha for her support and guidance in completion of the works.

REFERENCES

- [1] Norton braian (2013) Harnessing Solar Heat. springer. ISBN 978-98-528021.
- [2] Heinz, Gunter & Hautzinger, Peter (2007). "meat drying". Meat processor small scale industry. RAP publication. Bangkok, Thailand: Regional Office for Asia and the Pacific, Food and Agriculture Organization of the United Nations. ISBN 978-95-98-9321 Achieved from original on 23 May 2010.

- [3] Oyunbayar, N. "Mongolian Food: Meat, milk and Mongolia". Mongoluls.Net. Archived from the original on 5 April 2005.
- [4] Shaffer, Marcella (1999). "Solar Food Drying". Backwoods Home Magazine. No. 58. Archived from the original on 16 August 2000.
- [5] Trim, D. S. & Curran, C. A. (1983). "Solar dryers". Comparative Study of Solar and Sun Drying of Fish in Ecuador. London: Tropical Products Institute. ISBN 978-0-85954-158-9. Archived from the original on 2 September 2015.
- [6] Shaffer, Marcella (1999). "Solar Food Drying". Backwoods home Maxine. No. 58. Archived from the original on 16 August 2000.