

Review on Numerical Analysis of Solar Still for Optimum Solar Glass Surface Inclination at Different Water Level

Shobhik Rakshit¹, Prof Anand deo Singhal²

¹Research Scholar, Srist Jabalpur, (M.P.)

²Asst. Prof., Srist Jabalpur, (M.P.)

Abstract - Water is one of the most important components of Earth. It is very important for the existence of human life. It is available on Earth in abundance but very less of its availability comes under human use. Fresh and potable water is the most prominent issue at present. About 71% of Earth is covered with water, out of which 96.5% is ocean water and rest exists in river and lake, in pond, in ice caps and glaciers, in the soil and in aquifers, etc.

Index Terms - Solar Still, Solar Glass, Surface Inclination etc.

I.INTRODUCTION

1.1Introduction

Out of all these, only less than 1% of water is worth for human which is fresh. Issue of potable water is growing day by day [1]. There are many factors which are responsible for the depletion of such less available freshwater. Some of them are increasing population, industrialization, urbanization, transportation, etc. There is a need of water for various purposes like cooking, farming, drinking, and many more. Thus, safe water is a big challenge for current and future generations.

The lack of access to freshwater has an adverse effect on common people's life. There are many waterborne diseases which are being spread only because of lack of freshwater. Poor people are the main victims of this crucial problem [3]. Also, in some of the regions like deserts, arid region, etc., there is very less rainfall which causes an adverse effect on human life.

1.2 Desalination: A Solution

Water shortage is one of the toughest and threatening issues of today's generation. More than 15% of the world's population is deprived of fresh and potable water, out of which some are living in improper sanitation and unhygienic surroundings. To overcome

this deteriorating condition, more and more water is made from seawater which is available in abundance on Earth [9]. This very process can be successful with desalination. Desalination is one of the simplest, earliest, best solutions to freshwater shortage.

1.3 Methods of Desalination

Basically, there are various methods of desalinating brackish and salty seawater. Commercially and economically out of all methods, MSFD, RO, and MED are taken into account for the desalination purpose. It has been observed that these three methods are the leading ones and in the coming future these three would be the most competitive [8]. There are various methods of desalination which are as under.

- Multi-stage Flash Distillation (MSFD)
- Multiple-Effect Distillation (MED)
- Vapor Compression Distillation (VCD)
- Reverse Osmosis (RO)
- Freezing
- Solar Distillation
- Solar Still

Water is the most important component of our planet. It covers about 75% of the Earth, but still out of that much abundant water only 1% can be used as domestic purpose, perhaps which are being contaminated by various factors like pollution, sewage disposal, etc. There is a need to obtain freshwater, and most of the water present on the Earth is brackish and salty. Desalination is one of the measures to get freshwater from brackish water. To utilize desalination as an important measure, solar still is being introduced in this developing world. Solar still is a device which is completely based on the principle of desalination. It mainly uses the concept of solar distillation. It is now being used worldwide mainly in coastal areas where seawater is available in abundance. It is simple, cost-effective, and easily maintained process. The main

disadvantage of solar still is that it has less productivity. Various research and developments are going on so as to enhance the efficiency of solar still. For the development and modification of solar still, various research is going on the basic design of solar still to increase its productivity and make it more cost effective. The main idea for increasing the productivity of solar still is by increasing heat transfer rate. To implement this very idea, many researchers have used fins.

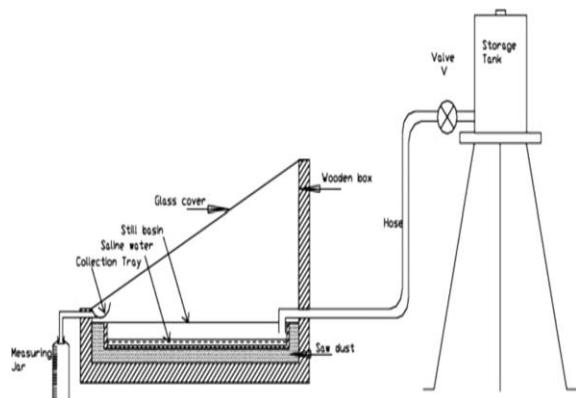

Figure 1 Solar still with simple basin

Here, still basin is painted black and is enclosed within the wooden box. Wooden box acts as a casing for still. There is a need of insulation in the still; hence, saw dust is used. It is filled below the still basin. To collect the condensate after condensation of the evaporated water, collection tray is used which is fixed to the wooden box and thus freshwater is collected.

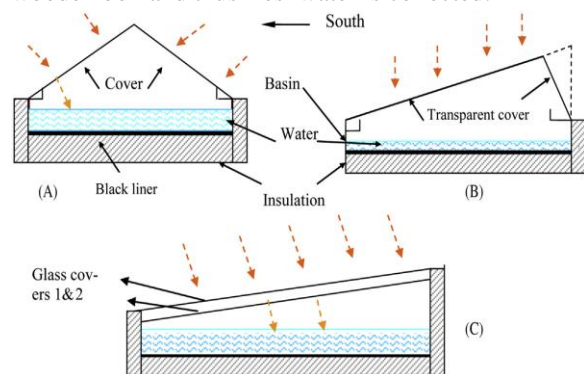

Figure 1.2 Sketches of the conventional simple symmetric and asymmetric stills: (A and B) with one cover glass and (C) with two cover glasses.

Conventional solar still is a simple device as presented in Fig. 1.2. It is termed “greenhouse type” as its operation is based on the greenhouse effect. Other expressions are “roof type,” “tent type,” etc. It can be symmetrical (double slope, Fig.1.2 a) or asymmetrical (single slope) as shown in Fig. 1.2 b and c.

According to operation mode, they are divided into:

- Passive solar stills which are simple stills that accomplish their operation without circulation of feed water. The basin is refilled early, every morning, about sunrise time.
- Active solar stills are conventional or not conventional solar stills where the water in the basin circulates, in very low flow rate, by the use of a pump, running by height difference from a storage tank or usually by connection to a solar collector which increases as well the saltwater feed temperature.

Working principle of solar stills

Solar distillation is the process which basically uses the heat of the sun directly for obtaining useful water from the salty brackish or sea water. The equipment or the device used is known as solar still. The solar still consists of a shallow basin blackened from the inside to absorb high amount of incident rays and is covered with a transparent glass cover. Figure 1.9 presents a schematic diagram and components of a traditional solar still built from a single basin contain saline water and covered by an inclined single glass cover. To reduce heat losses to surrounding the basin was insulated with glass-wood, fiberglass, and wood (Sahoo et al., 2008).

Classification of solar stills

The simple solar still is the oldest and most basic, low-tech desalination system currently in use. Many improvements have been suggested over the years to improve its efficiency. Different kinds and designs of solar stills have been available in today’s worldwide including basin and wick stills. Then, water vapor from the hot saline water is condensed for the production of distilled water. A conventional solar still has one basin with no heat recovery from the transparent cover which results in a low efficiency. Nonetheless, various basins may be piled to improve heat. Various solar stills were developed and estimated for comparison with conventional stills.

II-LITERATURE REVIEW

Mohammed Shadi S. et al; 2016 aims to investigate the different parameters that affect solar still productivity when the solar still productivity is very low compared with other desalination systems, such as other thermal

processes or membrane processes. These parameters include environmental, design and operational parameters. The results show that productivity was highly affected by environmental parameters due to the unpredictability of metrological factors. When design and operational parameters were varied, increases in productivity were observed. The results indicated that the solar still was inversely affected by evaporation area, water depth, a minimization in the angle of the solar still cover during summer seasons and maximization during winter seasons. Stepped solar still techniques enhanced the productivity, and the addition of wicks in a stepped solar still was proposed. Insulating the sun tracking system positively affected the productivity because the insulation increased the heating capability and evaporative effects inside the still basin.

Sampathkumar et al.; 2010. states that various advanced technology desalination techniques using fossil fuels or electrical energy derived from fossil fuels, are used world-wide, such as reverse osmosis, electrodialysis, ozone, UV, vapor compression and active carbon filtration to obtain potable water. Although these techniques are capable of desalinating water, they directly contribute to global warming and incur high costs. Additionally, these technologies are commercially suited for large cities and have high efficiencies and productivity rates when non-natural energy sources are used. Therefore, to provide fresh water to arid and semi-arid areas where sunshine is readily available, relative to non-natural energy, these methods are not suitable.

Zarasvand Asadi et al.; 2013 claimed that a solar still is an environmentally friendly energy or green energy process that uses the free natural energy of sunlight to purify contaminated water to produce clean water. The solar still process is able to replace fossil fuels by using solar energy to gain the power needed for purification. A solar still system has many advantages over other distillation systems. For instance, a solar still system uses free and clean energy and is environmentally friendly. Furthermore, no moving parts making it easy to construct and maintain. A solar still system does not require skilled manpower can be manufactured locally and can be easily repaired using natural building materials. Finally, a solar still system requires minimal investments, minimizes waste and is highly efficient in distilling even saline water (i.e., seawater)

Pankaj Dumka et al; 2019 made an attempt to compare the performance of conventional solar still (CSS) with the CSS augmented with 100 sand-filled cotton bags (called as modified solar still (MSS)). For the purpose, two identical single slope solar stills were fabricated. The bags were placed vertically at equidistance in the basin area for the enhancement of sensible energy storage capacity and water surface area (due to capillary action within the sandbags). Outdoor experiments were conducted in the month of January and February 2019, at Raghogarh, Guna (24° 39'N, 77° 19'E), India with 30 kg and 40 kg basin water. It has been observed that the cumulative distillate yield of MSS for 30 and 40 kg basin water were higher by 28.56 and 30.99% respectively. The overall efficiency of MSS is enhanced by 31.31 and 28.96% as compared with the CSS for 40 kg and 30 kg basin water respectively.

III-CONCLUSION

The performance of passive solar still is numerically evaluated under the weather conditions at India. The various variables can be considered for the study like water level, glass surface inclination in a typical passive type solar still. After the result analysis of previous study following conclusions can be made:

- When the water level considered the maximum amount of water collected for 3c.m. water level for all the angle of inclinations.
- As the water level decreases the water fraction collected increases.
- As the turbulence increases the kinetic energy increases thus the evaporation rate also increases.
- While in case of fluid particle velocity the lowest value is achieved when the inclination angle is 32°. The contour shows the resultant velocity (resultant of u, v and w components of velocity) of the fluid particle and due to high turbulence, the resultant velocity shows minimum value.

REFERENCES

- [1] A.F. Mohamed, A.A. Hegazi, G.I. Sultan, Emad M.S. El-Said, "Enhancement of a solar still performance by inclusion the basalt stones as a porous sensible absorber: Experimental study and thermo-economic analysis", *Solar Energy Materials and Solar Cells* 200 (2019) 109958

- [2] Ayman Refat Abd Elbar, Mohamed S. Yousef, Hamdy Hassan, “Energy, exergy, exergoeconomic and enviroeconomic (4E) evaluation of a new integration of solar still with photovoltaic panel”, *Journal of Cleaner Production* 233 (2019) 665-680
- [3] A.S. Abdullah, F.A. Essa, Z.M. Omara, Y. Rashid, L. Hadj-Taieb, G.B. Abdelaziz, A.E. Kabeel, “Rotating-drum solar still with enhanced evaporation and condensation techniques: Comprehensive study”, *Energy Conversion and Management* 199 (2019)
- [4] Dev R, Tiwari GN. Characteristic equation of a passive solar still. *Desalination* 2009; 245:246–65.
- [5] Dwivedi VK, Tiwari GN. Experimental validation of thermal Model of a double slope active solar still under natural circulation mode. *Desalination* 2010; 250:49–55.
- [6] K. Sampathkumar, T.V. Arjunan, P. Pitchandi, P. Senthilkumar, Active solar distillation—a detailed review, *Renew. Sust. Energ. Rev.* 14 (2010) 1503–1526
- [7] Mohammed Shadi S. Abujazar, S. Fatihah, A.R. Rakmi, M.Z. Shahrom, “The effects of design parameters on productivity performance of a solar still for seawater desalination: A review”, *Desalination* 385 (2016) 178–193
- [8] Pankaj Dumka, Aman Sharma, Yash Kushwah, Aman Singh Raghav, Dhananjay R. Mishra, “Performance evaluation of single slope solar still augmented with sand-filled cotton bags”, *Journal of Energy Storage* 25 (2019) 100888
- [9] R. Zarasvand Asadi, F. Suja, M.H. Ruslan, N.A. Jalil, The application of a solar still in domestic and industrial wastewater treatment, *Sol. Energy* 93 (2013) 63–71