

Early Intensive Care Unit Mortality Prediction

Mrs. Vidhya k¹, Sahana K R², Sahana L³, Shreya Rajgopal⁴, Sinchana P⁵

¹ Assistant Professor, Department of Information Science and Engineering, East West Institution of Technology, Visvesvaraya Technological University, Karnataka

^{2,3,4,5} Student, Department of Information Science and Engineering, East West Institution of Technology, Visvesvaraya Technological University, Karnataka

Abstract - The intensive care unit (ICU) is a complex and information rich department. Patients admitted to ICUs require close and continuous monitoring due to high illness severity and the potential for rapid disease progression. Early hospital mortality prediction is critical as intensivists strive to make efficient medical decisions about the severely ill patients staying in ICU. As a result, various methods have been developed to address this problem based on clinical records. With the development of techniques for data storage with the help of cloud, machine learning (ML) method have attracted considerable research attention with Random Forest (RF), decision tree (DT), k-nearest neighbor (KNN), Naïve Bayes (NB) which have a good performance. Medical information mart for intensive care (MIMIC III) benchmark dataset is used. In order to predict the risk, quantitative features have been computed based on the sensors like heart rate signals, humidity of ICU, body temperature of patients, equipment's condition of ICU. Data were prepared and feature selection was processed under the supervision of the ICU equipment's. Also, the system consists of a response button which helps to know about the cause of death. These results demonstrate the ability and efficiency of our approach to predict ICU mortality.

Index Terms - Intensive care unit, machine learning, dataset, sensors, response button, mortality prediction.

I. INTRODUCTION

Health care is an important field which makes human being strong and protects from different types of diseases and disasters. Intensive care unit (ICU) is a ward in hospital, where seriously ill patients are cared by specially trained staff. Quick and correct decisions for the patients are required. As a result, a wide range of decision support systems have been deployed to take a special care and attention for patients who have a high risk of mortality. The ICU patients are highly monitored to measure the physiological data using

electronic equipment, which provides a great opportunity for valuable clinical data analysis. The use of ICU data in the prediction of early mortality is an attractive open space for the investigation, for the two main reasons of quality and cost. Unexpected deaths which are still common despite evidence that patients often show signs of clinical deterioration hours in advance, can be detected by introducing a response button which gets notified for the patient's caretakers and doctors by which within the specified time the doctor must visit the ICU and treat the patient. Classification methods that apply advanced machine learning techniques to, ICU patient data have been proposed to successfully improve ICU mortality prediction over severity score systems. In healthcare problems features (e.g., diagnosis, symptoms and lab results) have different effects on patients based on the problem requirements. Machine learning approaches have the advantage where it is easy to continuously update and rectify, with algorithms should be customized in a way that enables continuous training based on new data obtained from the clinical tests. This study focuses on all the age patients admitted to ICU for any reason. Features selected are those that provide all the information about the patient: their age, gender, length of stay, admit type and etc. The main objective was to predict the ICU patient's death state with summarized data and check the accuracy by assigning test data patients to the closest cluster. By using ML and IoT the model ensures monitoring of the patient and equipment in the ICU room. Gives alert when the equipment isn't working. Updates each sensor reading to the cloud. Alerts when there is need to attend the patient if there are any changes in the sensor value. Predicts the reason of death. Updates the visiting of the doctor to the specific ICU using a response button. A new intervention is that the model

notifies the patient’s relative about the conditions and alerts if there is any emergency of the patient.

II. EXISTING SYSTEM

A life-threatening illness that occurs when the body is not responding to the infection and is out of balance. It can affect body changes that are more dangerous and may damage multiple organ systems and lead to death. This results with high risk of complications and in-hospital death, longer hospital stays and higher medical costs. Patient vital signs, laboratory results and demographic statistics are risk factors and time consuming. There is no specific alert message for the respective doctors and for the hospital staffs about the ICU, if patient’s temperature or heart rate varies or equipment’s condition changes.



Figure 1: Displaying more of human involvement

III. PROPOSED SYSTEM

Given the poor performance of existing severity scores, some new models have been developed for predicting the risk in-hospital death among the ICU patients. Technology plays a major role in our day-to-day life and in today’s time it seems impossible to have a day without techno goods. So, the proposed system is a modern ICU based health monitoring system which acquires the data from sensors and collect all the medical data of a patient including his/her heart rate, body temperature, ICU temperature and equipment’s condition and would send the data to the patient’s doctor regarding his/her full medical information, providing a reliable and fast healthcare service and also able to predict of any failure in system using ML algorithms and IoT hardware. The system consists of a response button which helps to know about the cause of death.



Figure 2: Displaying the advantage of using technology

IV. ARCHITECTURE

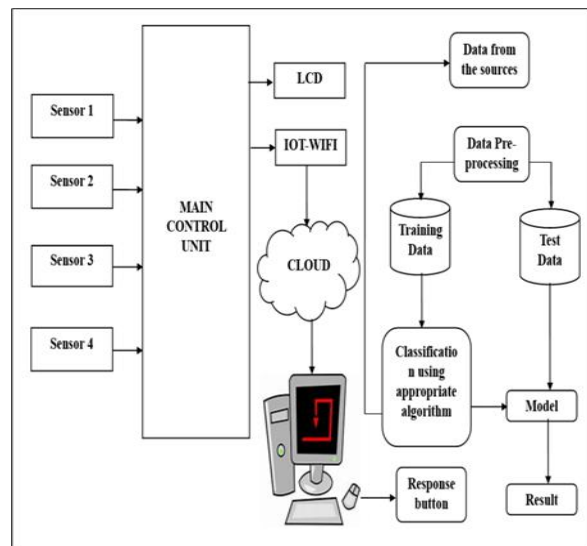

Figure 3: Block diagram

V. METHODOLOGY

The sensors allow you to receive data from regular electronic control units and output is generally a signal that is converted to human-readable display. Main control unit develops a module responsible for scaling data in the desired range of values from hardware module. To develop a predictive model, which will be based on the information received, to form indications for subsequent processing by the notification system that is, LCD and IOT Wi-Fi. The data which is recorded is stored in the cloud because these are designed to store and manage data, run applications, or deliver content such as streaming videos, web mail, office productivity software, or social media. The monitoring server will be implemented on the monitoring device itself and data is collected to

perform the machine learning technique to obtain a best predictive model. Data collection is the process of collecting and calculating information on selected variables in a fully completed system. The errors that can be occurred during data collection can be reduced by selecting appropriate data collecting tools and instruments which may be existing, can be modified or it can even be new with clear instructions for their proper use. Data preprocessing is a technique that includes converting the raw data into a clean and proper data set. In other words, whenever the data is combined from different sources it is collected in unprocessed format which is not practicable for the analysis. Data analysis is the process where collecting and arranging of data takes place in order to give appropriate conclusions from it. Data splitting is a common practice in machine learning to split our data into two separate datasets like training data and testing data. When we come across with a large set of data, we use the major portion of data as a training set. After providing training data, now it is the time to test that how much our model has learned from that data. After splitting the data, model is trained and classification using appropriate algorithm is done to get best model. Gaining the insights from machine learning technique and IOT we sought to create an accurate predictive model.

VI. ALGORITHMS

a) Random forest – It is a supervised learning algorithm that builds multiple decision trees and merges them together to get a more accurate and stable prediction.

Working of Random Forest:

Step 1 – Select the random samples from a given dataset.

Step 2 – It will construct a decision tree for every sample. Then it will get the prediction result.

Step 3 – In this step, voting is performed for every predicted result.

Step 4 – At last, select the most voted prediction result as the final prediction result.

b) Decision Tree algorithm - It belongs to the family of supervised learning algorithms. The decision tree algorithm can be used for solving regression and classification problems too. The goal of using a Decision Tree is to create a training model that can use to predict the class or value of the target variable by

learning simple decision rules inferred from prior data (training data).

Working of Decision Tree:

Step 1 - Pick the best attribute/feature. The best attribute is one which best splits or separates the data.

Step 2 - Ask the relevant question.

Step 3 - Follow the answer path.

Step 4 - Go to step 1 until you arrive to the answer.

c) K-nearest neighbors (KNN) algorithm – It is a simple, supervised machine learning algorithm that can be used to solve both classification and regression problems.

Working of K – Nearest Neighbor:

Step 1 - We must load the training as well as test data.

Step 2 – Next, we need to choose the value of K i.e. the nearest data points.

Step 3 – For each point in the test data do the same steps (Repeat).

d) Naïve Bayes - It is a classification technique based on Bayes' Theorem with an assumption of independence among predictors. In simple terms, a Naive Bayes classifier assumes that the presence of a particular feature in a class is unrelated to the presence of any other feature.

Working of Naïve Bayes:

Step 1 - Calculate the prior probability for given class labels.

Step 2 - Find Likelihood probability with each attribute for each class.

Step 3 – Put this value in Bayes Formula and calculate posterior probability.

VII. ADVANTAGES

- Provides alert message for hospital team, doctor and also the caretaker.
- Response button helps to react at the appropriate time to the patient.
- Able to determine the cause of death.
- Higher Performance

VIII. HARDWARE MODULES

a. Arduino UNO – It is an opensource hardware and software company. The board consists of analog and digital I/O pins which has a special feature to connect computer with the help of universal serial

bus (USB) which helps to load the programs and perform certain operation.

- b. 16*2 LCD display - It is an electronic display module that uses liquid crystal to produce a visible image. The 16*2 LCD display is commonly used in all the IOT projects. As the name itself indicates 16*2, 16 represents the character per line and 2 represents the number of lines it consists.
- c. WIFI microchip - The ESP8266 is a low cost WIFI microchip, this small module allows microcontrollers to connect to a Wi-Fi network and make simple TCP/IP connections using Hayes-style commands. It has only few important components on the module. Most of the hackers use this WIFI chip as it enhance to explore more data.
- d. ThingSpeak - It is an open-source Internet of Things (IoT) application and API to store and retrieve data from things using the HTTP and MQTT protocol over the Internet or via a Local Area Network. Once the data is put into ThingSpeak channel, we can analyse and imagine, calculate new data, or communicate with social media, web services, and other devices.
- e. Humidity sensors – It detect the relative humidity of the immediate environments in which they are placed. The sensors measure both the moisture and temperature in the air and express the relative humidity as a percentage of the ratio of moisture in the air to the maximum amount of moisture that can be held in the air at the current temperature. As air becomes hotter, it holds more moisture in the atmosphere, so the relative humidity changes with the temperature.
- f. Heart rate – It is the speed of the heartbeat measured by the number of contractions (beats) of the heart per minute (bpm). The heart rate can vary according to the body's physical needs, including the need to inhale oxygen and exhale carbon dioxide, but is also modulated by a scores of factors including but are also not limited to genetics, physical fitness, stress or psychological status, diet, drugs, hormonal status, environment, and disease/illness as well as the interaction between and among these factors.
- g. Voltage sensor - The ZMPT101B Single Phase Voltage Sensor has a PCB mounting and can measure within 250V AC. This single base

voltage transformer module produces an analog output that can be adjusted with the corresponding quantity. If we change the input voltage, the output voltage is also changed accordingly.

- h. Temperature sensor - The LM35 is an integrated circuit sensor that can be used to measure temperature with an electrical output proportional to the temperature (in °C). It can measure temperature more correctly than using a thermistor. The sensor circuitry is closed and not subject to oxidation. The LM35 produces a higher output voltage than thermocouple device and will not be required to increase the output voltage.

IX. RESULTS

The result from this project is that all the sensors reads the values from the patient and the surroundings. The data read from the sensors will be considered as the test data. This test data is fed into the model also along with test data standard pre-defined MIMIC-3 dataset is used. Then it is transferred to the cloud using WIFI module. On the other side the training data that has all the possibilities regarding the sensor reading is fed into the model. The model classifies the data and predicts the result using ML algorithms. If there is any emergency the doctor and the patient's well-wisher receives the alerts message to attend the patient. When the doctor attends the patient and presses the response button. This response button it indicates that the doctor has attended the patient. When the patient's hospital ID and other details is entered, it displays the patient condition i.e., mortality whether the patient will die or not. According to the status, a doctor can quickly start further treatments.

X. CONCLUSION

Early hospital risk of mortality prediction in ICU units is critical due to the need for quick and accurate medical decisions. This project proposes a new signal based model for early mortality prediction. Based on the limitations, a hybrid framework is proposed which can utilize the ICU data property sufficiently. We demonstrate the capability of using statistical and signal-based features, the heart-rate signals, equipment condition, room and body temperature to distinguish between patients who survive or pass away in the ICU.

REFERENCES

- admissions from the emergency department,” IEEE Access, vol. 6, pp. 10458–10469, 2018.
- [1] Z. Rayan, M. Alfonse, and A. M. Salem, Intensive Care Unit (ICU) Data Analytics Using Machine Learning Techniques, vol. 26, no. 1. Sofia, Bulgaria: ITHEA, 2019, pp. 69–82.
 - [2] G. Rouleau, M.-P. Gagnon, and J. Côté, “Impacts of information and communication technologies on nursing care: An overview of systematic reviews (protocol),” Systematic Rev., vol. 4, no. 1, pp. 1–8, Dec. 2015.
 - [3] T.Gentimis,A.J.Alnaser,A.Durante,K.Cook,andR .Steele,“Predicting hospital length of stay using neural networks on MIMICIII data,”in Proc. IEEE 15th Intl Conf Dependable, Autonomic Secure Comput., 15th DASC/PiCom/Data Com/CyberSciTech), Nov. 2017, pp. 1194–1201.
 - [4] R. Sadehi, T. Banerjee, and W. Romine, “Early hospital mortality prediction using vital signals,” Smart Health, vols. 9–10, pp. 265–274, Dec. 2018.
 - [5] C. Lee and T. Rainer, “Application of APACHE II in the assessment, classification of severity and predictive ability of chinese patients presenting to an emergency department resuscitation room,” Hong Kong J. Emergency Med., vol. 9, no. 4, pp. 188–194, Oct. 2002.
 - [6] S. Jeong, “Scoring systems for the patients of intensive care unit,” Acute Crit. Care, vol. 33, no. 2, pp. 102–104, 2018.
 - [7] D.Sun,H.Ding,C.Zhao,Y.Li,J.Wang,J.Yan, and D.W.Wang, “Value of SOFA,APACHEIV and SAPSII scoring systems in predicting short-term mortality in patients with acute myocarditis,” Oncotarget, vol. 8, no. 38, pp. 63073–63083, Sep. 2017.
 - [8] M. K. Moridani, S. K. Setarehdan, A. M. Nasrabadi, and E. Hajinasrollah, “Analysis of heart rate variability as a predictor of mortality in cardiovascular patients of intensive care unit,” Biocybern. Biomed. Eng., vol. 35, no. 4, pp. 217–226, 2015.
 - [9] R. Pirracchio, M. J. Cohen, I. Malenica, J. Cohen, A. Chambaz, M. Cannesson, C. Lee, M. Resche-Rigon, and A. Hubbard, “Big data and targetedmachinelearninginactiontoassistmedicaldecisionintheICU,”AnaesthesiaCrit.CarePainMe., vol.38, no.4, pp. 377–384, Aug.2019.
 - [10] B. Graham, R. Bond, M. Quinn, and M. Mulvenna, “Using data mining to predict hospital