

Solar Inverter Connected with Grid

Snehal A Ingewar¹, Pravin Mandvikar², Yogeshree Dhakate³

^{1,3} Mtech PEPS

² Mtech IPS

Abstract- A Solar Inverter or PV inverter, is a type of electrical converter which converts the variable Direct Current (DC) output of a Photovoltaic (PV) Solar Panel into a Utility Frequency (AC) that can be fed into a Commercial electrical grid or used by a local, off-grid electrical network. It is a critical balance of system (BOS) component in a photovoltaic system, allowing Photovoltaic (PV) solar inverter is equipment that converts the DC output of solar batteries to the AC power which meets the requirements of the grid, its performance and quality are directly related to the photovoltaic effect on the public grid. Current national standard specifies only the requirements for protection and did not develop appropriate testing rules and procedures. This paper researched and developed the PV grid-connected inverter detecting platform, analyzed the PV grid-connected inverter protective function and testing methods and procedures. We realized the PC integration of the system and the automatic test of the inverter by using Kingview software, to ensure the reliability and accuracy of test results, in addition, the host computer system has proved ease of use, stability and scalability.

Index terms- Photovoltaic power generation; photovoltaic grid-connected inverter; automatic detecting platform; kingview

I. INTRODUCTION

PV grid-connected inverter is the core component of PV power generation systems, so it should have perfect protection measures. Therefore, it is necessary to have further study on the performance of the test, and build test platform, to ensure the reliability of test results.

Energy shortage and environment pollution have become the biggest problems facing humanity. In order to solve these problems, the development of clean renewable energy resources will play a vital

role in future energy structure. The radiation of the sun can say mine, an inexhaustible, thus promoting the use of solar energy is an inevitable trend in the future.

This paper introduced the PV grid-connected inverter testing platform in detail, analyzed the protect function and testing methods and steps of the inverter. The platform is constituted of industrial PC, RS232 and RS485 and GPIB bus system. The software of the whole system using King view is of good usability, stability and expansibility.

II. THE COMPOSITION AND FUNCTION OF THE SYSTEM

The PV grid-connected inverter testing platform is provided for distributed power grid testing laboratory, used for the testing grid inverter, and to verify whether the inverter meet the requirements of the power grid.

The platform consists of primary system and secondary system. By changing the parameters of equipment operation in the primary system, to simulate the test conditions. The secondary system is used for the data acquisition and information records, to provide basis for the analysis of test results.

1. Primary system

The primary system consists of photovoltaic cell simulator, power grid simulator, impedance network simulator, load network simulator, DC switch control cabinet, AC switch control cabinet and the short circuit control cabinet. The system block diagram is shown in figure 1.

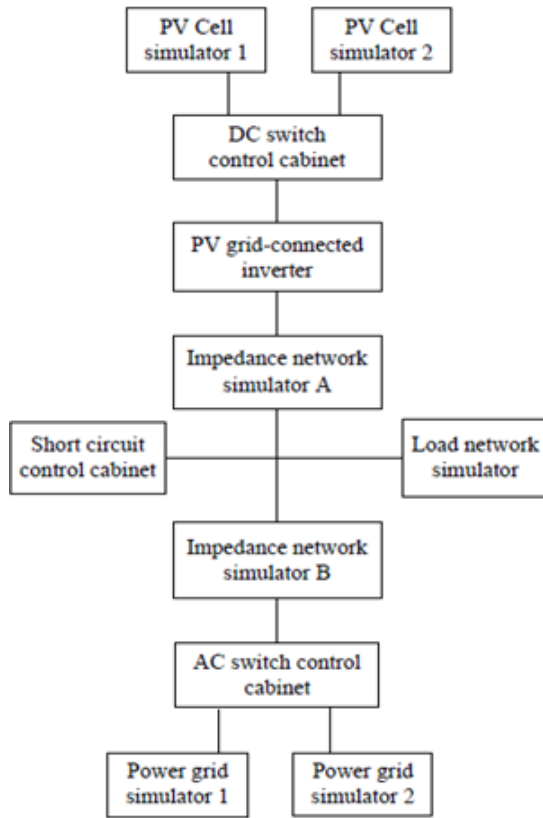

Fig. 1: System block diagram

Power grid simulator is used to simulate the pure power grid, whose output can be programmed to simulate various grid test conditions. The two impedance networks are used to simulate the impedance of the long lines between inverter and ac power grid to the user load respectively. Load network simulator is used to simulate the user load. DC switch control cabinet and AC switch control cabinet are used to gate the DC and AC power supply respectively in the test. In this system, by adjusting the analog power supply and load simulation to simulate the actual running state, to provide reliable test conditions for the inverter.

2. Secondary system

The secondary system consists of a power analyzer, a power quality analyzer and a data recorder.

The power analyzer is used for measuring voltage, current, frequency, harmonics, power, power factor, the dc component and voltage unbalance degree of the AC access point, and voltage, current, power, ripple coefficient and other parameters of the dc side. The power analyzer is equipped with four channels, the inverter DC input voltage, current and the AC

output three-phase voltage, current were measured. The measuring point distribution is shown in table 1.

Measurement point distribution of power analyzer	Points amount
Measured parameters	
PV cell simulator output voltage	1
PV cell simulator output current	1
Inverter output voltage	3
Inverter output current	3

It can measure the effective value of voltage and current, frequency, power, power consumption (quantity of electricity), degree of imbalance and flicker, etc. The power quality analyzer based on the platform feature also has the function of fault detection, data acquisition, besides the functions above. The power quality analyzer which has the external communication interface and external operated display unit can carry out remote monitoring and communication at the same time. It also can measure harmonic to 63 times, detect the imbalance degree of three-phase, transient spike pulse signal and the surge current. The measured points can be selected in the inverter ac output side or communication choice ark output side according to the requirements of different tests.

III. PV GRID-CONNECTED INVERTER TEST

Reference to the photovoltaic inverter product classification, terms and definitions, technical requirements, test methods, inspection rule and marks, packaging, transportation and storage, specified in relevant certification standard, we designed the test for PV grid-connected inverter.

The tests accomplished at present include:

1. Low voltage test
2. Over voltage test
3. Low frequency test
4. Over frequency test
5. Conversion efficiency test
6. Voltage harmonic test
7. Current harmonic test

IV. SOFTWARE DESIGN

The diagram of the automatic detection platform concludes equipment layer, system layer, and the test

layer. The equipment layer respectively establishes operation interface for the equipment needing remote monitoring. The system layer establishes the whole structure of the testing platform which can monitor the power information and the running condition of each node. The testing layer establishes the automatic test interface. This can eventually realize purpose of completing the test by one key.

The devices that need to be automated monitoring and operation include: PV cell simulator, power grid simulator, DC switch control cabinet, AC switch control cabinet, short circuit control cabinet, impedance network simulator, load network simulator, power analyzer, power quality analyzer.

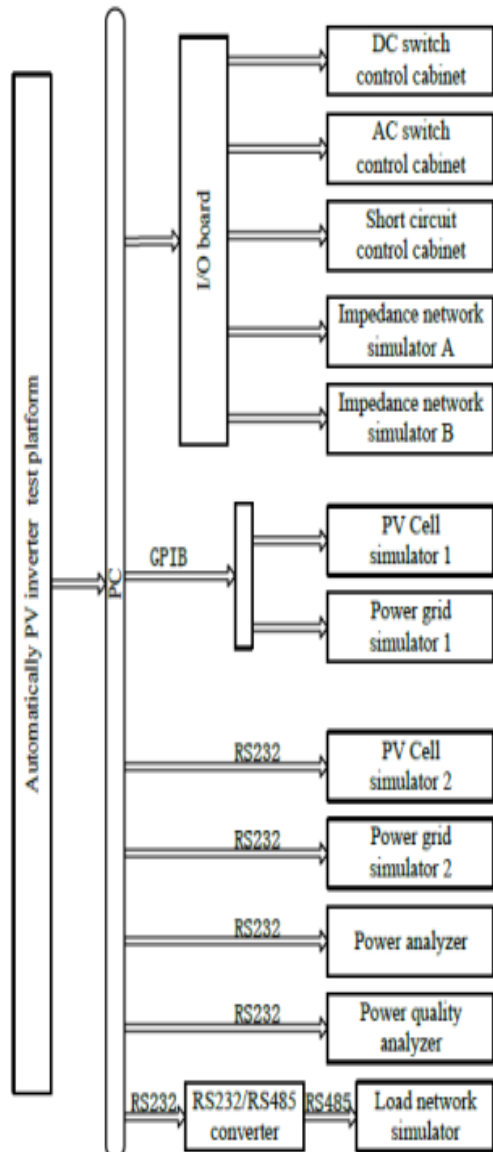

Fig. 2: Software system block diagram

1. System layer

The automatic test platform built in this paper integrate all the equipment needed to be controlled in the same project. This project can display the main parameters of the system and the state of equipment, the parameters include: power grid simulator voltage, current, active and reactive power; inverter output voltage, current, active and reactive power; load network simulator voltage, current, active and reactive power. This system can also monitor the operation status of the system, including whether the line voltages and currents exist in order to provide security assurance for operation.

2. Equipment layer

The DC switch control cabinet, AC switch control cabinet, short circuit control cabinet, and draught fan of impedance network simulator should be controlled by the I/O control board. We choose the 32 bit digital I/O board card which is supported by Kingview to realize the signal communication between PC and equipment.

The drive program of PV cell simulator, power grid simulator, load network simulator and power analyzer need to be exploit respectively. After the drive program being exploited, we can build the automatic test platform by using Kingview software. Develop PC monitor interface menu for every equipment, which can read and operate the variable quantity that need to be controlled.

3. Test layer

The ultimate goal of the automatic test platform is to realize one key test. We add the test button on the main interface, by compiling the buttons command language to realize time delay, then carry out the test step by step. Besides an emergency stop button is added on the main interface, if an emergency occurs this stop button detach the whole system, it means disconnect the power grid simulator, PV cell simulator, to prevent shock and damage that might caused to the equipment. In the system, data recorders and power quality analyzers require manual operation during the test, the configuration will automatically pop king set a reminder, only after the operator execute appropriate settings the automatic test can continue. This will ensure the reliability of the test data record.

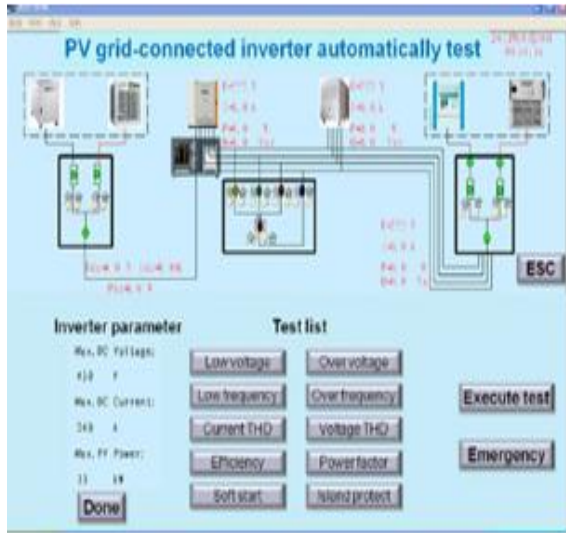

The main screen of the software system is shown in Fig3.

V .CONCLUSION

By building PV grid-connected inverter automatic test platform can provide uniform testing specifications for PV inverters connected to the grid. This research analyzes the related standards of domestic PV power generation system, propose specific test procedures and methods, and develop PV grid-connected inverter automatic test platform. The platform has been proved a fully functional system, device configuration, easy to operate, high accuracy and a high degree of automation

REFERENCES

- [1] GB/T 15945-2008. Power quality, power supply frequency deviation [S].
- [2] Q/GDW 480-2010. Distributed power grid technical requirements [S].
- [3] Q/GDW 617-2011. PV power plant connected to the grid technical requirements [S].
- [4] Q/GDW 618-2011. Photovoltaic power plants connected to the grid test procedures [S].
- [5] Q/TGS 1063-2011. Distributed power grid technical standards [S].
- [6] CNCA/CTS 0004-2009A. Grid-connected PV inverters technical conditions [S].
- [7] GB/T 19939-2005. PV systems and network technical requirements [S].

- [8] Ni Song, Kang Wei. PV grid-connected inverter certification [J]. Authentication technology,2010, (3):40-41.
- [9] Zhang Xin, Cao Renxian. Solar photovoltaic power generation and inverter control [M]. Beijing: Machinery Industry Press,2010.9:18
- [10] Yan Huaguang, Zhang Xin, Yang Xiangjiang, Wang He, Fan Ying, Jiang Limin, Li Taoyong. PV inverter testing platform development [J]. Grid, 2011, 5(6):139-143.
- [11] Wichert B, Dymond M, Lawrance W. Development of a test facility for photovoltaic-diesel hybrid energy systems[J]. Renewable Energy, 2001, 22(1):311-319.