

Electrical Power Generation Characteristics of PZT Piezoelectric Ceramics

Prince Kumar¹, Deepmala², Ravi Shekhar³

^{1,2} Department of Electrical Engineering, RKDF Inst. of Science & Technology, Bhopal. MP

³Amity School of Engineering & Technology, Amity University Patna, Patna. Bihar

Abstract - The electrical power generation characteristics of Mn-doped PZT ceramics responding to slow mechanical stress as well as to impact stress have been investigated. Although both the slow and impact stresses induce a reversible electrical response, the generation properties are distinctly different. Slow stress releases two output current peaks with opposite directions, responding to the increasing and decreasing part of the stress, respectively. However, impact stress produces a nearly one-directional signal. The output charge and energy by slow stress are found to be two orders of magnitude higher than that produced by impact stress. This work shows that the energy conversion efficiency of piezoelectric ceramics strongly depends on the method of stress application.

display, giving a self-diagnosis system for ceramics, and so on. However, these encouraging applications were found to depend on the electrical power generation characteristics of the used PZT ceramics. The present work aims to reveal the electrical output performance of PZT ceramics due to slowly applied stress as well as impact stress applications, both under a pressure lower than 30 MPa, which has been studied less. The results of this paper will give a basic knowledge about how to utilize PZT piezo ceramics in the new applications as power supply for displays like electrochromic and electroluminescent devices, as well as other active stress or strain sensors.

I. INTRODUCTION

Although a number of articles [1]–[14] have described the electrical response of lead zirconate titanate (PZT) ceramics to a very high mechanical stress on the order of a few GPa, little attention has been devoted to the electrical output energy in the low mechanical stress range, which is of increasing interest from the view point of smart materials and structures [15]. Our recent study demonstrated that combining PZT ceramics with structural material can result in a self-diagnostic system [16]. Furthermore, we recently found that the electrical energy generated from PZT ceramics during applied stress could drive either a WO₃ electrochromic device (ECD) [17] or an electroluminescence device (ELD) in certain instances, even under a stress lower than 10s of MPa [18]. In these instances, PZT ceramics were found to be capable to serve as the power supply for ECD and ELD, so that the mechanical stress signals are able to transfer to optical signals without an external electrical power supply. Such device properties are greatly promising to many new applications, for example, serving as an active stress sensor without external electrical power supply and

II. PROCEDURE

In the PZT family, the Mn doped Pb (Zr_{0.52}Ti_{0.48}) O₃ (PZT 52/48) is found to be an excellent piezoceramics with a high mechanical quality factor and a high electromechanical coupling coefficient [19]. In addition, the MN doped PZT 52/48 is promising to give an outstanding stability in the piezoelectric effect during applying mechanical stress cycling [20], [21]. Thus, we choose this material to discuss the electrical output performance responding to mechanical stress. For sample preparation, PbO, ZrO₂, TiO₂, and MnCO₃ powders (all with purity above 99.9%) were weighted to yield a composition of (Pb_{0.99}Mn_{0.01}) (Zr_{0.52}Ti_{0.48}) O₃. The constituents were mixed by ball mill in ethanol with zirconia balls of 5 mm in diameter for 24 h. Then the mixtures were pressed into disks of 30 mm in diameter and calcined at 800°C for 2 h. The obtained powders were ball milled again for 24 h in ethanol and mixed with organic binder after drying. The resulting powders were pressed into disks of 30 mm in diameter and 1.5 to 4.5 mm in thickness under a pressure of 30 MPa followed by a rubber press at 100 MPa. The

pellets were sintered at 1250°C for 2 h in PbO atmosphere. The fired specimens were cut to disks using a diamond cutter and a supersonic process machine, with the approximate dimensions as following:

specimen	Diameter(mm)	Thickness(mm)
A	24	3
B	24	2
C	24	1
D	10	1
E	3	10

The surface of each specimen was polished using a polishing machine. Ag electrodes were then pasted on both sides of the disk specimens by calcining at 700°C for 15 min. Poling treatment was carried out in silicone oil at 70°C for 5 min with DC electric field of 3.1 The principal

0885-3010/98\$10.00 ©1998 IEEE TABLE I Principal Properties of 1 at% MnO Doped PZT (52/48). KV/mm.

Density	K_p	K33	ϵ	Pr	E_c	E_{max}	Y33
g/cm ³			(at 1kHz)	$\mu\text{C}/\text{cm}^2$	KV/cm	KV/cm	N/cm ²
7.8	0.36	0.64	953	22.7	8.1	35.3	5.7×10^6

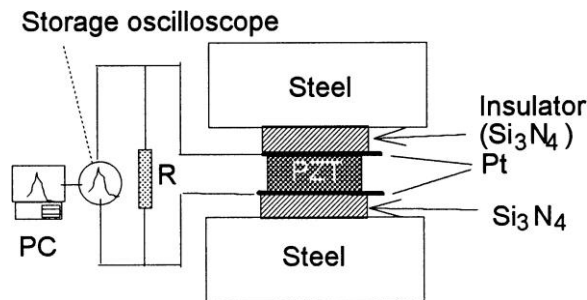

Fig. 1. An explanatory illustration for the constant rate loading experiment using testing machine. properties of the resulting material is shown in Table I. Here, all parameters were measured using methods recommended by the Electronic Material Manufacturers Association of Japan [22]; and only the specimens of dimension E were used for the evaluation of the K33 parameter.

The electrical output performance of PZT specimens during applying mechanical compressive stress was measured using two different techniques. One was to slowly apply the stress at a cross head speed of 1 mm/min using a material testing machine (DCS-2000, Shimadzu Corp., Kyoto, Japan). Fig. 1 shows an explanatory illustration for the constant rate loading

experiment. The electrical response of PZT specimens to applied stress was displayed on a digital storage memory oscilloscope (DCS-9320, Kenwood Corp., Tokyo, Japan) with an input resistance R of 107 ohms, which was connected to a personal computer (PC) for data analysis.

The other technique was to “drop weight impact” stress in a way as shown in Fig. 2. A steel ball with a plastic cover (14 mm in diameter, 5.97 g in weight) was dropped from a height (0 to 250 mm) through a steel guide pipe, thereby applying an impact to the test PZT specimen. In this case, the time from 0 stress to peak stress was found to be about 100 microseconds, as detailed in Section III, B. For comparison, a steel ball (13.76 g) without plastic covers was also used as the free-falling ball instead of the steel ball with a plastic cover.

For the measurement of electrical power generation during applied stress, the specimens with dimensions of A, B, C, and D were examined. Because the specimens with dimension A were most mechanically strong for stress application, we will concentrate on describing the results of this dimension unless noted otherwise.

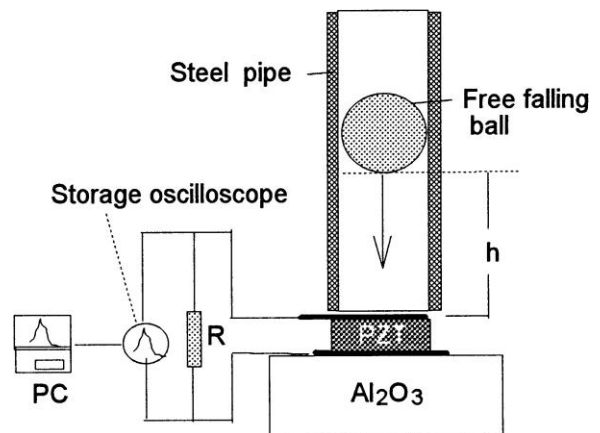

Fig. 2. Schematic drawing of the impact testing.

III. RESULTS AND DISCUSSION

A. Response to Slowly Applied Stress

Fig. 3 shows the typical electrical output curves of PZT specimens under slowly applied compressive stress for a sample of 24 mm in diameter and 3 mm in thickness (dimension A). Two electrical output currents with opposite directions were observed during one slowly applied stress cycle, responding to the increasing stress and decreasing stress,

respectively. The released electrical charge and energy caused by the increasing stress were found to be the same in value as those due to decreasing stress (see Table II). For example, with 21 MPa, the released charge and energy for increase and decrease stress were 1.78 μC , 131 μJ and 1.74 μC , 130 μJ , respectively. Such a reversible response to stress changes confirmed that the test specimens functioned in the linear region of the piezoelectric effect. When the applied stress was removed from the test specimens, the polarization of the PZT recovered to the initial state. This paper deals with the results in the linear region.

Similar results were obtained for the PZT samples with dimensions of B, C, and D. The charge density and the energy density shown in Table II were not dependent on the thickness and diameters of the examined samples.

TABLE II Comparison of the Released Charge and Energy Responding to Increase and Decrease Stress for 1 at% MnO Doped PZT (52/48).

Electrical output	Loading 9 MPa		Loading 21 MPa		Loading 28 MPa	
	Increase	Decrease	Increase	Decrease	Increase	Decrease
Charges (μC)	0.48	0.42	1.78	1.74	3.91	3.72
Charge density ($\mu\text{C}/\text{cm}^2$)	0.10	0.09	0.39	0.38	0.85	0.81
Energy (μJ)	14.6	14.1	131	130	440	431
Energy density ($\mu\text{J}/\text{cm}^2$)	3.17	3.06	28.5	28.3	62.5	62.0

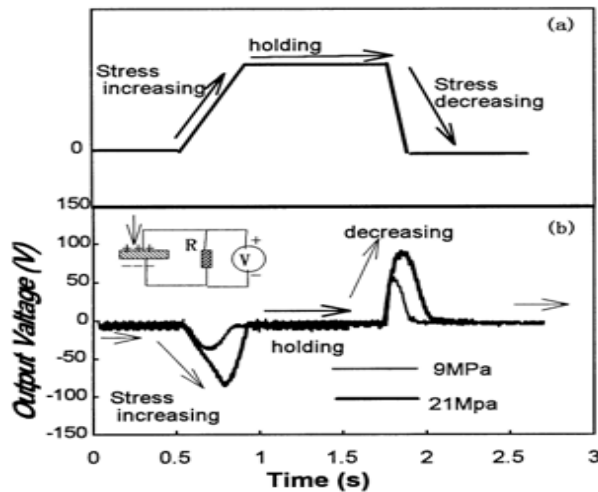

Fig.3. Typical electrical output characteristics for 1 at% MnO doped PZT 52/48. (a) The applied stress cycle, increasing linearly followed by holding at constant then decreasing to zero stress. (b) Piezoelectric output curves due to the increasing and decreasing stress, about 0.5 and 0.1 $\mu\text{C}/\text{cm}^2$ [1], [23], respectively, which were smaller than that given by the materials in the

We found no literature concerning electric output of Mn-doped PZT; therefore, we compared our data to that reported for other PZT. Under the pressure of 28 MPa, the released charges for $\text{Pb}(\text{Zr}_{0.50}\text{Ti}_{0.50})\text{O}_3$ and $\text{Pb}_{0.99}\text{Nb}_{0.02}(\text{Zr}_{0.68}\text{Ti}_{0.07}\text{Sn}_{0.25})\text{O}_3$ were reported to be present study. However, for soft compositions, like PZT (56/44) and La doped PZT (65/35), they were reported to give larger values, 2.5 and 12 $\mu\text{C}/\text{cm}^2$ [23], [24], respectively, under the same pressure. But these soft compositions of PZT respond to mechanical stress irreversibly due to their easy ferroelastic switching. As a consequence, their output degrades under stress cycling. The threshold stress for ferroelastic switching was reported as low as 5 MPa for PLZT (8/65/36). Contrary to the soft compositions, Mn doped PZT (52/48) showed reproducible

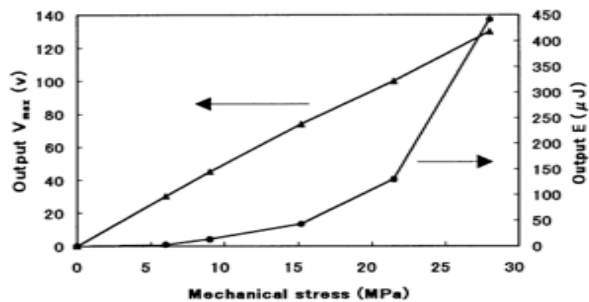
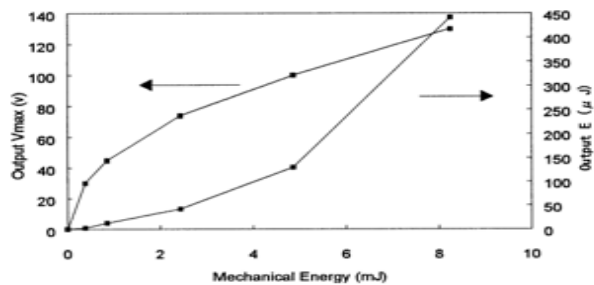

Fig.4. The dependence of output voltage and energy on mechanical stress with slowly applied stress



recovered to the initial state. This paper deals with the results in the linear region.

Similar results were obtained for the PZT samples with dimensions of B, C, and D. The charge density and the energy density shown in Table II were not dependent on the thickness and diameters of the examined samples.

We found no literature concerning electric output of Mn-doped PZT; therefore, we compared our data to that reported for other PZT. Under the pressure of 28 MPa, the released charges for Pb ($Zr_{0.50}Ti_{0.50}$) O₃ and Pb_{0.99}Nb_{0.02}(Zr_{0.68}Ti_{0.07}Sn_{0.25}) O₃ were reported to be present study. However, for soft compositions, like PZT (56/44) and La doped PZT (65/35), they were reported to give larger values, 2.5 and 12 $\mu\text{C}/\text{cm}^2$ [23], [24], respectively, under the same pressure. But these soft compositions of PZT respond to mechanical stress irreversibly due to their easy ferro elastic switching. As a consequence, their output degrades under stress cycling. The threshold stress for ferroelastic switching was reported as low as 5 MPa for PLZT (8/65/36). Contrary to the soft compositions, Mn doped PZT (52/48) showed reproducible response curves to stress cycles and no degradation was observed in the entire examination period.

Fig. 4 illustrates stress-voltage and stress-energy relations. The peak values of the released electrical voltage (V_{max}) were found to increase linearly with the increase of

Fig. 5. Relations between the mechanical input energy and the electrical output energy in the case of slowly applied stress.

the applied stress. However, the released energy increased almost exponentially in the high stress region. A tendency similar to energy-stress also was found for charge-stress.

The mechanical energy input into the PZT test specimens due to the compressive stress can be estimated from elastic equations. For calibration, strain gauges also were used for measuring the strain-stress curves of the samples. The experiments give the same results as estimated from the elastic equation. The electrical output energy and output voltage versus mechanical input energy are shown in Fig. 5. The output V_{max} initially increased with increasing input energy, but tended to saturate in the high input energy region. On the contrary, the electrical output energy increased continuously in the entire test region. The conversion ratios of energy from mechanical input to

electrical output were found to be on the order of several percentages. Although these values are smaller than those estimated from the electro-mechanical coupling factor, k_{33}^2 (ca.41%), of this material, they are of a comparable order. Because our purpose is to investigate the electrical energy generation characteristics without an external circuit, no large capacitors were used in our experiments (see Section II). To obtain more consistent data to that of k_{33}^2 , an external electrical circuit should be utilized between the oscilloscope and the test specimen [24].

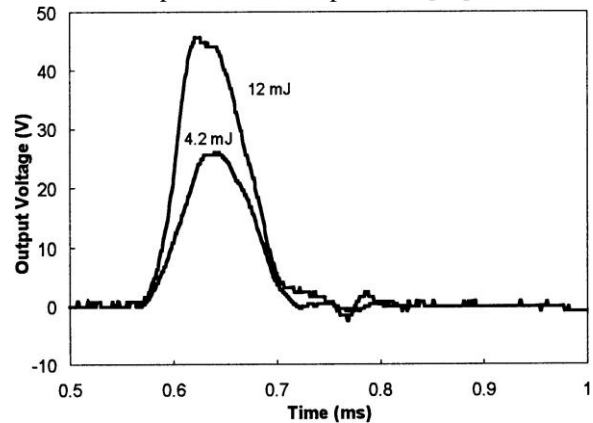

Fig. 6. Typical response curves of piezoelectric voltage to the impact stress.

B. Response to Impact Stress

Fig. 6 shows the electrical output curves of a PZT specimen to impact stress introduced by dropping a steel ball with plastic cover on the specimen (as shown in Fig. 2). The released electrical signal lasted about 100 microseconds, which was much shorter (e.g., 1/1000) than that released with slowly applied stress (refer to Fig. 3). With most test specimens, the RC-time constant was about 17 msec, so the lasting time of one mechanical impact should be the same as the electrical response time. Note that the results are very different from the results obtained with slowly applied stress, electrical output of the reverse direction during removing impact stress nearly disappeared. Only a very small signal in the reverse direction was observed by applying high impact energy (12 mJ), as shown in Fig. 6, which may be caused by the relaxation effect. A steel ball without a plastic cover also was used in our experiments. Similar response curves were observed as shown in Fig. 6.

For the above measurements, because the specimens with thickness of 1 mm (C and D) were easily

fractured by the impact stress, only specimen B was measured to compare with A. Similar results were obtained, regardless of the thickness of the test specimen.

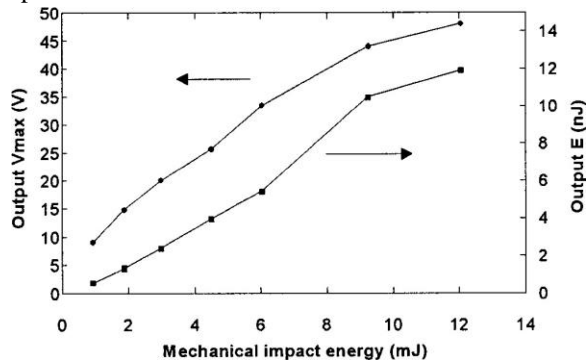

Fig. 7. Relations of electrical output energy as well as voltage to mechanical input energy with impact stress application.

The relationship of output energy and voltage to mechanical impact energy are shown in Fig. 7. Compared to the results for slow stress as shown in Fig. 5, it is apparent that similar peak values of output voltage can be obtained from both stress methods: impact and slow. However, the released energy from impact stress (in nJ order) was much lower than that released from slowly applied stress (μJ order). The conversion ratio of energy thus derived was on the order of 10^{-6} for impact stress. This is much lower than that given by slow stress application (10^{-2}) as described in Section III, A. Many factors may be responsible for such a low energy conversion, such as the area of the applied stress, the output electrical matching, and the mechanical matching. To reveal the effect of the area of applied stress, an alumina block with dimension of 10 mm in diameter and 10 mm in height also was used to apply the impact stress. The piezoelectric output, however, showed no significant difference from those shown in Fig. 7, although the alumina block gave impact stress on a much larger area than that by the steel ball. The low conversion ratio of energy in the impact stress seems to be mainly caused by the poor energy transferring from the impact mechanical energy into PZT test specimens. More detailed work concerning the electrical output in various mechanical matching cases as well as electrical matching cases are now underway and will be reported later.

IV. CONCLUSION

The electrical response characteristics of Mn-doped PZT ceramics to slowly applied stress as well as to impact stress have been investigated using an open circuit with an input resistance of 10^7 ohms. Main results are summarized as follows:

- The PZT test specimens responded to a slowly applied stress, both in increasing stress and in decreasing stress, producing two electrical output currents with opposite directions. Impact stress released almost one direction current flow. *xu et al.*: piezoelectric ceramics characteristics
- The electrical charge and energy released from increasing stress and decreasing stress were equivalent for slow stress.
- The energy conversion efficiency derived from the electrical-stress response was comparable to the data calculated from the electro-mechanical coupling factor K_{33}^2 , in slow stress. Such a relation did not exist with impact stress.
- The electrical voltage released from slowly applied stress was found to be of the same order as that released from the impact stress, although the latter released a much lower electrical energy.

REFERENCES

- [1] D. Berlincourt, "Transducer using forced transitions between ferroelectric and antiferroelectric states," *IEEE Trans. Sonic Ultrason.*, vol. SU-13, pp. 116–125, 1966.
- [2] D. Berlincourt and H. H. A. Krueger, "Domain process in lead titanate zirconate and barium titanate ceramics," *J. Appl. Phys.*, vol. 30, pp. 1804–1810, 1959.
- [3] C. S. Lynch, "The effect of uniaxial stress on the electromechanical response of 8/65/35 PLZT," *Acta Mater.*, vol. 44, pp. 4137–4148, 1996.
- [4] P. C. Lysne and C. M. Percival, "Electric energy generation by shock compression of ferroelectric ceramics: Normal-mode response of PZT 95/5," *J. Appl. Phys.*, vol. 46, pp. 1519–1525, 1975.
- [5] P. C. Lysne, "Dielectric breakdown of shock-loaded PZT 65/35," *J. Appl. Phys.*, vol. 44, no. 2, pp. 577–582, 1973.
- [6] P. C. Lysne and L. C. Bartel, "Electromechanical response of PZT 65/35 subjected to axial shock loading," *J. Appl. Phys.*, vol. 46, pp. 222–229, 1975.

- [7] P. C. Lysne, "Shock induced polarization of a ferroelectric ceramics," *J. Appl. Phys.*, vol. 48, pp. 1024–1031, 1977.
- [8] W. J. Halpin, "Current from shock-loaded short-circuit ferroelectric ceramics disk, *J. Appl. Phys.*, vol. 37, pp. 153–163, 1966.
- [9] R. K. Linde, "Depolarization of ferroelectrics at high strain stress," *J. Appl. Phys.*, vol. 38, pp. 4839–4842, 1967.
- [10] W. Mock, Jr. and W. H. Holt, "Pulse charging of nanofared capacitors from shock depoling of PZT 56/44 and PZT 95/5 ferroelectric ceramics," *J. Appl. Phys.*, vol. 49, pp. 5846–5854, 1978.
- [11] J. T. Cutchen, "Polarity effects and charge liberation in lead zirconate titanate ceramics under high dynamic stress," *J. Appl. Phys.*, vol. 37, pp. 4745–4751, 1966.
- [12] Y.-L. Wang, W. Z. Yuan, G. R. He, S. W. Lin, C. F. Qu, and B. G. Wang, "Study on shock wave-explosive energy converter of PZT 95/5 ferroelectric ceramics," *Ferroelectrics*, vol. 49, pp. 169–176, 1983.
- [13] R. P. Spears, "Dielectric characteristic of PZT 95/5 ferroelectric ceramics at high pressure," *Ferroelectrics*, vol. 37, p. 653, 1981.
- [14] C. E. Reynolds and G. E. Seay, "Two-wave shock structure in the ferroelectric ceramics barium titanate and lead zirconate titanate," *J. Appl. Phys.*, vol. 33, pp. 2234–2241, 1962.
- [15] S. W. Freiman and G. S. White, "Intelligent ceramics materials: issues of brittle fracture," *J. Intel. Mater. Syst. Struct.*, vol. 6, pp. 49–54, 1995.
- [16] M. Akiyama, K. Nonaka, T. Watanabe, and K. Miyazaki, "Self-detection of fracture in PZT and MoSi₂-MoB₂ layered composite ceramics," *J. Ceram. Soc. Jpn.*, vol. 102, pp. 686–688, 1994.
- [17] C. N. Xu, M. Akiyama, P. Sun, and T. Watanabe, "Novel approach to electrochromism in WO₃ thin film using piezoelectric ceramics as power supply," *Appl. Phys. Lett.*, vol. 70, pp. 1639–1640, 1997.
- [18] submitted for publication.
- [19] W. Heywang and H. Thomann, "Tailoring of piezoelectric ceramics," *Amer. Res. Mater. Sci.*, vol. 14, pp. 27–47, 1984.
- [20] H. Ouchi, "Piezoelectric ceramics material," *N. Tech. Rep.*, vol. 22, pp. 720–740, 1976.
- [21] H. Ohanessian, P. Gonnard, M. Troccaz, L. Eyraud, and P. Eyraud, "Stability of PZT type piezoelectric ceramics under fast uniaxial stress," *Rev. Phys. Appl.*, vol. 18, pp. 479–486, 1983 (French).
- [22] Electronic Material Manufacturers Association of Japan, "EMAS-6100: Standard for testing piezoelectric ceramics," 1993 (Japanese), Electronic Material Manufacturers Association Press, Tokyo, Japan.
- [23] D. A. Berlincourt, C. Cmolik, and H. Jaffe, "Piezoelectric properties of polycrystalline lead titanate zirconate compositions," *Proc. IRE*, vol. 48, pp. 220–229, 1960.
- [24] J. A. Close and R. Stevens, "The transient piezoelectric response of impact loaded PZT ceramics," *Ferroelectrics*, vol. 134, pp. 181–187, 1992.