

Microcontroller Based an Autonomous Wireless Line Tracking Robot

AmanSingh¹, Shripad G. Desai²

¹Student, Department of Electrical Engineering, Bharati Vidyapeeth (Deemed to Be University), College of Engineering, Pune, India

²Assistant Professor, Department of Electrical Engineering, Bharati Vidyapeeth (Deemed to Be University), College of Engineering, Pune, India

Abstract - This venture is going to assemble an independent robot which is a Pick and Place Robot utilizing Line Tracking. This venture contains three fundamental parts which are electric circuit, mechanical plan, and programming. To fabricate a decent self-ruling robot, the robot should be effectively and uninhibitedly n e d to be constrained by the pilot to ensure it can perform well. Usually, this robot is utilized to pick and place things, for some capacity like in processing plant, send the holder from front of line to end of line or some other capacity that need to send thing from other spot to each other spot. Fundamentally, this robot utilizes a few sensors to manage the course which has been fixed with dark tape and the robot is utilizing a few engines for the developments. This venture centers around the utilization of PIC as a regulator, engine as a mover and sensor as the line guider. This robot capacities completely constrained by programming which are programmable.

Index Terms - PIC 16F877A, Radio-frequency identification (RFID), Pick and Place Robot.

1.INTRODUCTION

A robot can be characterized as a programmable, self-controlled gadget comprising of electronic, electrical, or mechanical units. All the more by and large, it is a machine that capacities instead of a living specialist. Robots are especially desirable for certain work functions because, unlike humans, they never get tired; they can work in physical conditions that are uncomfortable or even dangerous; they can operate in airless conditions; they do not get bored by repetition; and they cannot be distracted from the task at hand. This article is based on the research project which is an autonomous robot to be use in food industry. The robot is powerful, reliable and can be

used in hot temperature area where a human after working for so long can become sick and exhausted. The most apparent reasons that are associated in installing of robotic systems in food industry are

- Saving of manpower
- Improved quality & efficiency.
- Ability to work in any hostile environment.
- Increased consistency & flexibility.
- Increased yields and reduced wastage.

In today's fast paced world competition in industrial field is very fierce. Time is money than more than ever before. Efficiency and productivity are very important. This loss in time can be reduced or eliminated by using mobile robots with arm that can carry a heavy load that may need many people to carry. In this way, the manpower is reduced. Many factors are needed to be considered in manpower. The main factor is the fatigue. Break time should be given to avoid over fatigue.

Conveys it and afterward drops it at somewhere else. These activities can be customized in a microcontroller in the right arrangement. Just when the mechanical plan is finished, we can begin with the electronic circuit plan and interfacing them

1. Necessities of a decent robot configuration incorporates. The robot must be as light as possible.
2. The arm should be rigid enough to withstand forces generated due to
 - Its own body weight
 - Weight of the object to be lifted.
 - Inertia forces due to change in velocity
 - Centrifugal forces due to change in velocity
 - The cost should be minimized.

2. EXISTING SYSTEM

In the before innovation, they were numerous techniques used to plan and actualize, and furthermore various calculations were utilized for exploring the portable robot. Dissimilar to standardized tags, not away from of sight is needed to acquire an exact read. As the scanner tags were high of cost, we are utilizing the RFID Tags. The most well-known and mainstream route procedures proposed in the cutting edge by and large fall under one of the accompanying classes: map-based method, dead-retribution based strategy, milestone-based procedure, vision-based procedure, and conduct based strategy. Every route method has its own favorable circumstances and impediments.

2.1. Dead Reckoning-

Dead retribution route framework gives position, heading, direct, and rakish speed of an independent versatile robot and it is broadly utilized because of its straightforwardness and simple upkeep. The inadequacies of the dead-retribution route framework are that little accuracy blunders and sensor floats unavoidably lead to expanding combined mistakes in the robot's position and direction, except if an autonomous reference is utilized occasionally to address the blunder. To defeat these inadequacies, scientists moved their regard for milestone based portable robot route framework.

2.2. Vision Based Navigation-

Where a mobile robot uses visual features to guide itself in the environment. Such techniques also revealed some disadvantages, which include the lack of information depth, complex image processing algorithms with high computational burden, and the dependence on the working environment.

2.3. Behavior Based Navigation-

Another exploration road was to pick conduct-based route frameworks. This kind of ideal models was credited to be reasonable for unstructured conditions as they can consolidate countless sensors. They can likewise be went with devices of calculation knowledge, for example, fluffy rationale, neural organizations, hereditary calculations, and a few mixes of them. All things considered, conduct based route methods additionally require a high computational force and at times they lead to huge

aggregate mistakes because of the unavoidable commotion related to the sensor estimations.

To defeat a portion of the negative marks of the previously mentioned strategies, coordinating RFID frameworks arose of late as a promising elective route technique. In certain examinations, RFID labels are set in predefined areas in the workspace and the robot is pre-outfitted with a RFID peruse to speak with the labels during its route in the climate.

3. PRAPOSED SYSTEM

To beat the above issues, we are utilizing the distinctive procedure and microcontroller. The usage of RFID innovation is novel and might upgrade the existed mechanization framework. The PIC (16F877A) Microcontroller I s used to control the proposed independent portable robot and to speak with RFID peruse. Because of the uniqueness of RFID tag, the moving control orders, for example, turn right, turn left, accelerate and speed down and so on the independent versatile robot can peruse the moving control orders from the labels and achieve the correct activities. The epic limitation framework for a portable robot is proposed to improve the effectiveness of the framework.

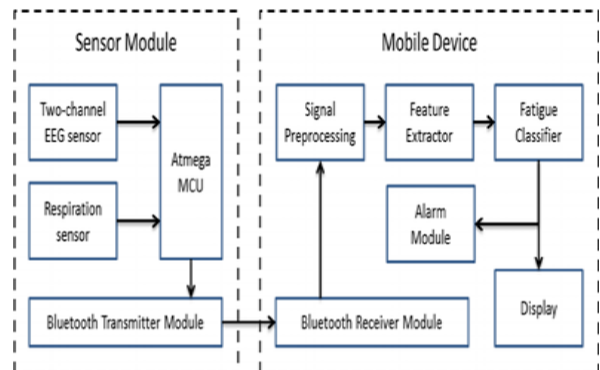

Fig 1. Block Diagram of Proposed System

3.1. Electronic Design

The segments that are required for the electronic circuit configuration incorporates Light Emitting Diode-Phototransistor sets, resistors, potentiometers, RFID Tag (transponder) and Reader, DC Geared engines, Motor Driver IC's and microcontroller. The microcontroller utilized here is PIC 16f877A. Either L293D or ULN 2003 can be utilized as engine driver IC however on the off chance that we use ULN 2003 IC, we need to interface transfers to offer inventory to the engines.

3.2 Block Diagram

The general activity or plan of the robot can be grouped into five squares which are, Power Supply block, Line Follower block, Controller block, Motor Driver Circuit block and the Radio Frequency Power supply is required for every single part utilized in the undertaking. The force source utilized is a 12V DC battery-powered battery. This 12V stockpile is straightforwardly given to the engines utilized however for the activity of the IC's 5V inventory is required and hence we associate a controller to the yield of this 12V battery.

7805 is a voltage regulator integrated circuit. It is a member of 78xx series of fixed linear voltage regulator ICs. The voltage source in a circuit may have fluctuations and would not give the fixed voltage output. The voltage controller IC keeps up the yield voltage at a consistent worth. The xx in 78xx demonstrates the fixed yield voltage it is intended to give. 7805 gives +5V controlled force supply. Capacitors of appropriate qualities can be associated at information and yield pins relying on the particular voltage levels.

- Light emitter: Light producer is on the information side and takes the approaching sign and converts it into light sign. Ordinarily light emanating diode is utilized as the light producer.
- Light detector: Light detector detects the light from the emitter and converts it back into electrical signal. The light detector can be a phototransistor.

4. LINE FOLLOWER

The line devotee is a self-working robot that recognizes and follows a line that is drawn on the floor. The way comprises of a dark line on a white surface (or it could be opposite of that). The control framework utilized should detect a line and move the robot to remain on course, while continually amending some unacceptable moves utilizing input instrument, along these lines shaping a basic yet powerful shut circle System. The robot is intended to follow tight bends. The way is a dark line on a white foundation with width of 3 cm (besides at twists where a little variety might be available). It might contain ways along the side dislodged by an around 3 cm and furthermore hole of all things consider.

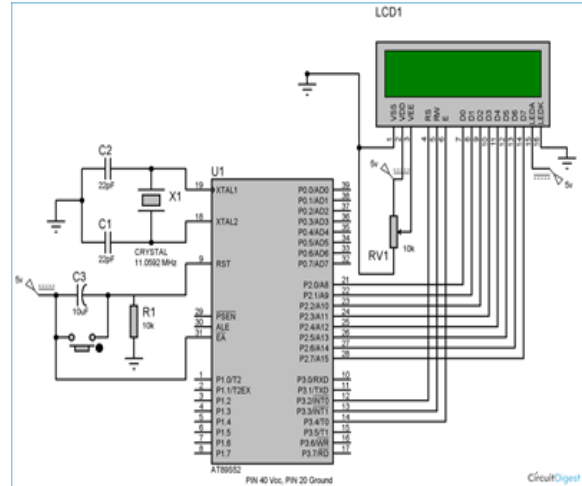

Fig 2 : Line Follower Circuit with LCD

4.1. Basic Design Requirement: -

The robot is worked with P I C 1 6 f 8 7 A, L293D, IR sensors, LM324, stage comprising of a toy vehicle suspension (or carefully assembled Al sheet case). The robot is planned utilizing two engines controlling wheels. It has infrared sensors on the base for identify dark following tape. It catches the line position with the assistance of these optical sensors called opt-couplers mounted at front finish of the robot. (Each opt-coupler comprises of an IR LED and an IR Sensor) when the sensors distinguish dark surface, yield of comparator, LM324 is low rationale and for white surface the yield is high. It reports to the microcontroller for precise control and guiding of engines. Microcontroller PIC 16f877A and engine driver IC's L293D and ULN 2003 are utilized to drive the engines.

5. RADIO FREQUENCY IDENTIFICATION

Radio-recurrence ID (RFID) is the remote non-contact utilization of radio-recurrence electromagnetic fields to move information, for the motivations behind consequently distinguishing and following labels connected to objects. A few labels require no battery and are controlled and perused at short ranges through attractive fields (electromagnetic acceptance). Others utilize a neighborhood power source and emanate radio waves (electromagnetic radiation at radio frequencies). The tag contains electronically put away data which might be perused from up to a few meters away. Unlike a bar code, the tag does not need to be

within line of sight of the reader and may be embedded in the tracked object.

The yield signal from the microcontroller is lacking to drive the engine. In this way, a driver IC is required between the microcontroller and the engine which intensifies the yield signal from regulator. The L293D is intended to give bidirectional drive flows of up to 600-mA at voltages from 4.5 V to 36 V.

The basic operations of the line follower are as follows.

- Capture line position with optical sensors mounted at front finish of the robot. For this a blend of IR LED's and Photo Transistor called an opt-coupler is utilized. The line detecting measure requires high goal and high power.
- Steer robot to follow the line with any guiding system. To accomplish this, we utilize two engines administering wheels movement.

5.1 Sensors

On the off chance that we have white surface it mirrors the light, and it will be detected by the collector, comparably in the event that we have dark surface it ingests the light and recipient cannot detect light. Photograph diode has property that if IR light fall on it its electrical position descends (for example it descends from 150kfi to 10kfi if no commotion present). For sense the adjustment in opposition we use voltage divider circuit.

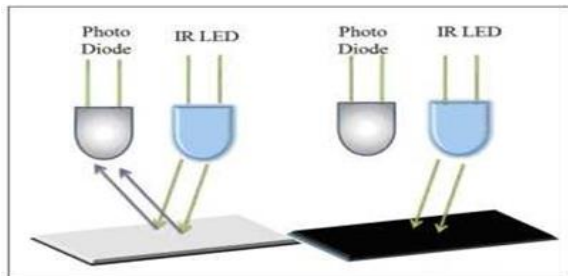

Fig 3. Sensor concept

The output signal from the sensor is fed as an input to one of the inverting terminals of the comparator which compares this signal with the reference voltage set by using a potentiometer which is fed to the non-inverting terminal of the comparator IC. When the sensor or emitter pair is on a reflecting surface, the sensor is on i.e., in low impedance mode in which one can easily view as LED corresponding to that sensor does not glow.

Regardless of whether the sensors are Light Dependent Resistors (LDR), laser diode, Infrared Sensors, Ultrasonic Sensors or whatever else, the

yields of the sensor modules are taken care of to the Non-altering contribution of a comparator. LM324 is a comparator IC that digitizes the simple sign from the sensor cluster. Since the yield of LM324 is TTL viable it tends to be straightforwardly taken care of to the expert microcontroller.

The generalized connection diagram of Sensor Interfacing with microcontroller is shown below.

In other words, it is used to adjust the sensitivity of the sensor.

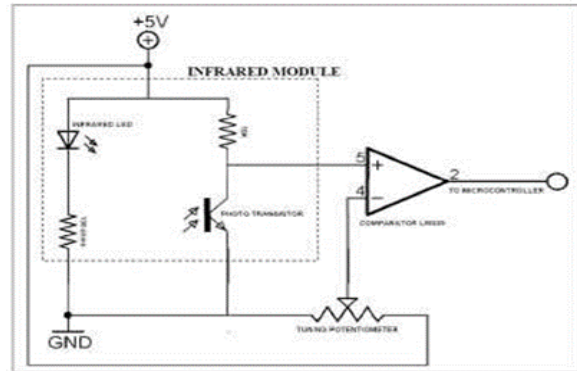

Fig 4. Sensor Interfacing with Microcontroller

When the power supply is given, the robot moves over the black line by continuously sensing the black and white. When the RFID reader detects the RFID tag, the mobility of the robot is stopped and the operation of the arm to pick the object starts.

6. CONCLUSION

A self-sufficient robot which can be controlled with remote innovation from the distant and this robot follows the line and move to the ideal area and perform pick and spot activity of thing. These Robots can be sent in essential areas and furthermore utilized for military for salvage mission. These Autonomous automated robots can speak with arrange and can perform better activity.

REFERENCES

- [1] Amit Kumar, M. Manjutha, A.K. Majumdar, J. Mukhopadhyay and Rusha Patra, "An Electronic Travel Aid for Navigation of Visually Impaired Persons", 3'd International Conference on Communication Systems and Networks, pp. I -5, January 20 I I.
- [2] Kenji Terada, Minoru Fukumi and Stephen Karungaru, "Improving Mobility for Blind

- Persons using Video Sunglasses",pp. I -5, February2011.
- [3] Aura Ganz, Carole Wilson, Gray Mullet and Siddesh Rajan Gandhi," INSIGHT: RFIO & Bluetooth Enabled Automated Space for the Blind &Visually Impaired", 32nd Annual International Conference on 2010 Engineering in Medicine and Biology Society, pp.331-334, September.
- [4] Barroso J, Faria J, Fernandez H, Martins P, "Electronic White Cane for Blind People Navigation Assistance", World Automation congress, pp. 1-7, September 2010.
- [5] Oimitrios Oakopoulos and Nikolaos G.Bourbakis, "Wearable Obstacle Avoidance Electronic Travel Aids for Blind: A Survey", IEEE Transactions on Systems, Man and Cybernetics, Vo1.40, No.1, pp.25-35, January 20 I O.
- [6] Manaswi M. Lathe1, S. B. Patil, February 2014, Online Monitoring and Alarm Indication of Status of Air for Automation, International Journal of Science and Research (IJSR) ISSN (Online): 2319 7064, Volume3.
- [7] Fundamentals of Wireless Sensor Network Theory and Practice, 2010, A John Wiley and Sons, Ltd., Publication.
- [8] J.Bird, Electrical circuit theory and technology, oxford: Newnes, 2003.
- [9] C.K.A.&. M.N. Sadiku, Fundamentals of electrical circuits.
- [10] I.S &. J Dunton, Practical Electronics Handbook, Oxford, 2007.
- [11] Venkata Naga RohitGunturi, "MICRO CONTROLLER Based Automatic plant irrigation system", International Journal of Advancement in Research and technology, 2013.