

# SMART AND SAFE HOME USING ARDUINO

Karthik Kumar Vaigandla<sup>1</sup>, Shivakrishna Telu<sup>2</sup>, Sandeep Manikyala<sup>3</sup>, Bharath Kumar Polasa<sup>4</sup>, Chelpuri Raju<sup>5</sup>

<sup>1</sup>Assistant Professor, Dept. of Electronics & Communication Engineering, Balaji Institute of Technology and Science, Warangal, Telangana, India

<sup>2,3,4,5</sup>UG Student, Dept. of Electronics & Communication Engineering, Balaji Institute of Technology and Science, Warangal, Telangana, India

**Abstract** - The primary goal of this project is to make it easier for users to control appliances wirelessly via remote controls and voice commands, as well as to include safety features in the event of gas leaks or fires. This concept has two components: wireless home security and home automation. The controller, which is presently being built as a prototype for this project, continuously senses the sensors and takes the necessary action in the event of a home security breach. The Controller then controls the relays depending on commands received via the Internet from the User in the case of home automation. Using the Internet of Things (IoT), we can remotely connect and monitor objects in the real world. In addition to making our home smarter, safer and more automated, it can also be effectively incorporated into this concept. An IoT project aims to build a safe and secure wireless home system.

**Index Terms** - Arduino, Home Automation, Internet of Things (IoT), Smart Home, Gas sensor, wi-fi module, Servo motor, LCD, Sensors.

## 1.INTRODUCTION

The concept of a smart device has grown in popularity as the internet of things (IoT) has progressed. Devices are linked to the internet, allowing them to expand their reach. The smart phone isn't the only popular smart device. Smart watches, smart rings, smart TVs, smart air monitors, smart sensors, and other classic items have evolved into smart devices that can connect to the internet [1]. This helps to spread the word about wireless home automation. Because home appliances are becoming smarter, the house or workplace can become a smart environment with simple automation control. This paper's smart switch can provide a single interface for customers to interact with their household appliances [1].

With the help of newly developed smart systems, technological advancements make human daily life easier. People are becoming more interested in using the internet to control and view many sorts of devices as a result of the rapid development of internet technology and smart embedded systems [2]. The Internet of Things (IoT) ushers in a new era of sophisticated intelligent computing, ushering in a new era of technological innovation [3][4]. The internet of things (IoT) is defined as the linking of a variety of devices, such as smart phones, computers, and tablets, to the internet, allowing for a whole new level of communication between things and people, as well as between things [5]. The main purpose of IoT is to make it easier, more emotive, and smoother to operate any electronic things or equipment around us [6]. IoT contributes to electric gadget significance by guaranteeing cost-effective living with protection, safety, and amusement. IoT technology is being used to come up with a ground-breaking notion and rapid growth for smart houses in order to improve living conditions [7]. Consumers have been increasingly interested in the concept of a smart house in recent years. IoT-enabled home automation is the subject of a lot of study.

The Internet has revolutionized people's lives by allowing them to communicate with others at any time and from anywhere. Sensors, processors, transmitters, receivers, and other devices have advanced at the same rate as generation [8]. Are now accessible at a very low cost. As a result, all of these topics can be applied to our daily lives. If everyone wants to increase their internet services, the Internet of Things can be described as an expansion of internet offerings. The Internet of Things (IoT) is becoming more prevalent in today's world (IoT). The concept of the Internet of Things (IoT) was introduced with the advancement of

the widely used international system known as the web, in conjunction with ubiquitous computing and mobiles in eager articles, resulting in new open doors for the creation of innovative solutions for various aspects of life. The Internet of Things (IoT) concept envisions a network of objects that can communicate, associate, and collaborate to achieve a common purpose [9]. IoT devices can improve our everyday lives since each device ceases to function as a standalone system and instead becomes a component of a larger connected system.

The internet is a network that connects current internet networks to computer structures with real-world products or things. Things can be anything, including household things, electronic devices, automobiles, and so on. And, because these devices communicate with the internet via standard protocols, the entire system is referred to as the Internet of Things (IoT). The Internet of Things (IoT) is a network of interconnected computing devices, mechanical and digital machines, gadgets, animals, or humans with unique identifiers (UIDs) and the ability to send data over a network without the need for human-to-human or human-to-computer interaction.

Because of the convergence of several technologies, such as real-time analytics, system reading, commodity sensors, and embedded structures, the meaning of the Internet of Things has expanded. Embedded systems, wireless sensor networks, control systems, automation, and other traditional fields all contribute to the Internet of Things' success. In the consumer market, IoT technology is most closely associated with products that support the concept of the "smart home," which encompasses devices and home appliances that control one or more common ecosystems and can be controlled by devices that are part of that ecosystem, such as smart phones and smart speakers [10].

## 2. IOT FOR SMART HOMES

IoT devices are a subset of the larger concept of home automation, which includes lighting, heating and cooling, media, and security. Long-term desires could link vitality venture reserves, ensuring that lights and equipment are not destroyed. Efforts are debating and identifying a large number of IoT-related applications, which can be divided into two categories. The gadgets are first grouped together, forming an automated

establishment with M2M connectivity and the potential to improve people's lives. TCC&R's activities is predicted by IoT in this class (track, request and control). For example, in nuclear families, the room temperature, windows, lights, and electrical devices would all be able to be controlled remotely from a PC and robotized, eliminating the need for the manual approaches that humans encounter on a daily basis. The Internet of Things (IoT) is widely accepted to have negative consequences in both modern and advanced societies. In today's information culture, the Internet of Objects (IoT) can be thought of as a comprehensive system that enables newly founded enterprises to begin using existing and best-in-class information and communication technologies by partnering real and virtual devices and things.

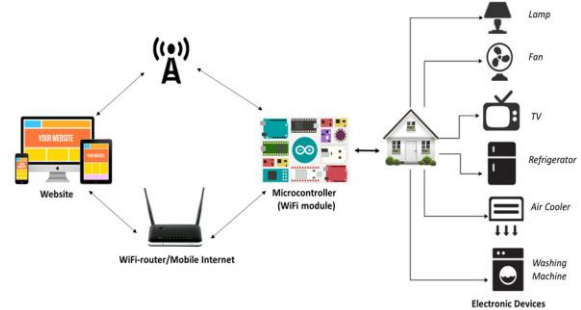

Figure 1. Internet of Things (IOT) : Smart Home System

## 3. SYSTEM OVERVIEW

As new technologies in electronics, communication, and sensor network systems are developed, security systems are rapidly evolving throughout the world. As a result, security vision has grown in strength. Alarm signals can be generated by the basic security system both inside and outside the perimeter under surveillance. With an alarm system that can also inform central stations, a greater and superior level of protection can be obtained.

### 3.1 Operation

The Flame sensor and the Gas sensor are constantly sensing. When the Gas sensor detects a gas leak, it sends a signal to the controller, which then notifies the user of the leak and activates the buzzer, LED, and exhaust fan to exhaust the gas from the room. The Flame Sensor, like the Gas Sensor, sends a signal to the controller when it detects a fire. The controller then notifies the user of the fire detection and activates the buzzer, LED, and water sprinkler to spray water all over the room to reduce the fire's spread. The

Controller controls the electrical appliances in accordance with the user's requests. The user can control (ON/OFF) the appliances in the house using the Blynk GUI interface. Google Assistant can also be used to operate the appliances. When no gas or fire leaks are detected by the sensors, the buzzer, led, water pump, and exhaust fan will be turned off.

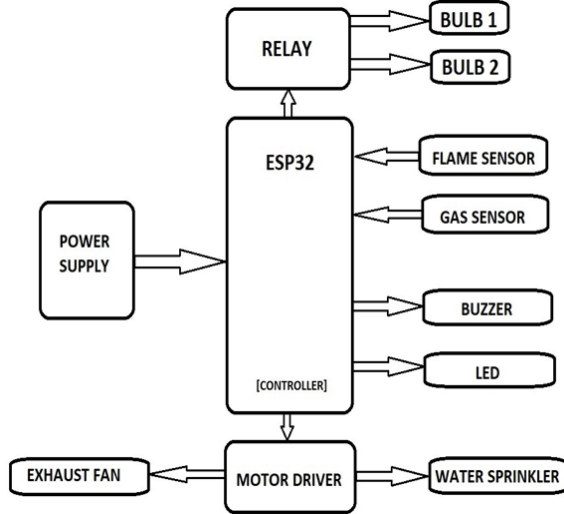

Figure 2. Block Diagram

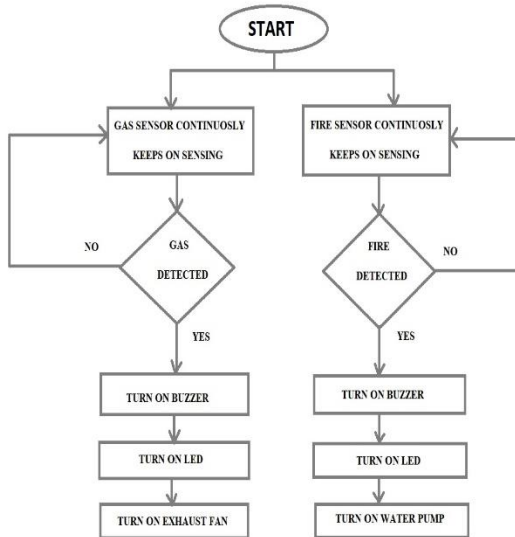

Figure 3. Flow Chart

### 3.2 Power Supply

Power Supply comprises mostly of a transformer that converts 230V ac to 9V ac, followed by diodes [11]. To correct the ac to dc, diodes are utilised. The resultant rippling dc is filtered using a capacitor filter after rectification. The resultant dc voltage is regulated using a positive voltage regulator [11].

### 3.2 Sensors

An instrument or an observer can read a sensor's signal, which is a measurement of a physical quantity. Each sensor must be calibrated against standard measurements to maintain accuracy [12]. Sensors are devices which detect and respond to signals. When we use the term "stimulus," we are referring to a property or quantity that requires electricalization.

A gas sensor detects the presence of various gases in an area, usually as part of a system to alert humans and animals about substances that could be dangerous to them [12]. Combustible, poisonous, oxygen, and CO2 gases can all be detected with gas sensors. A section for detecting a smoke signal that changes in reaction to detect the smoke density and output it. If a leak exists, cryogenics such as liquid nitrogen (LN2), helium (He), and argon (Ar) can render oxygen (O2) inert or deplete it in a confined space [12]. It will also identify this type of oxygen because a quick fall in oxygen can create a very unsafe atmosphere for personnel.



Figure 4. MQ2 Sensor Module

Flame Sensor Module: The flame and radiation are both harmful to this module. It can also identify conventional light sources with wavelengths ranging from 760nm to 1100nm. A detection distance of up to 100 cm is possible. A digital or analogue signal can be output by the Flame sensor. It can also be used as a flame detector.

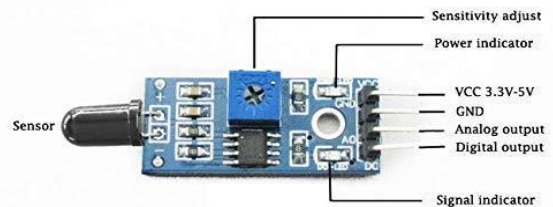

Figure 5. Flame Sensor Module

### 3.3 Stepper Motor and Driver Circuit

An electromechanical device that converts electrical pulses into discrete mechanical movements is known as a stepper motor. When electrical command pulses are supplied in the right sequence to a stepper motor's shaft or spindle, it turns in discrete step increments [12]. The applied input pulses have multiple direct links with the motor spinning. The direction of rotation of the motor shafts is directly related to the sequence of applied pulses. The frequency of the input pulses has a direct relationship with the speed of the motor shaft spinning [12].

The interface between digital circuitry and mechanical action is the driving circuit. High-powered actuators respond to binary commands sent from the computer. To regulate the rotational direction of DC motors, driver circuits are frequently utilised [12]. We'll need the driver circuits to control any robot with a motor, unless you buy a possibly pricey motor-driver.

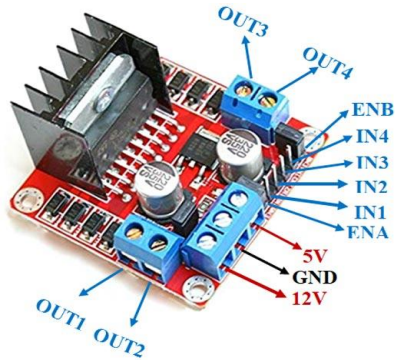

Figure 6. L298N Motor Driver

### 3.4 Buzzer

A buzzer, often known as a beeper, is a sound signalling device that can be mechanical, electromechanical, or piezoelectric in nature. Alarm clocks, alarm devices, and confirmation of client information, such as a mouse click or keystroke, are all common uses for signals and beepers [13]. A piezo bell is an electrical device that produces sound. It may be used in a variety of applications, such as auto/truck turning around markers, PCs, call chimes, and so on, because to its light weight, basic development, and low cost. The inverse law of piezo power, discovered by Jacques and Pierre Curie in 1880, governs piezo signal [13]. When mechanical weight is connected to specific materials, and the other way around is also valid, it is the wonder of producing power. These materials are referred to as piezoelectric materials. There are two types of piezoelectric materials: natural

and manmade [13]. Piezo clay is a type of man-made material that creates a piezoelectric impact and is commonly used to create circles, which are the heart of the piezo signal. When exposed to an alternating electric field, they stretch or pack in accordance with the recurrence of the flag along these lines, delivering sound [13].

### 3.5 ESP32-WROOM-32

The ESP32-WROOM-32 is a versatile Wi-Fi+BT+BLE MCU module that can handle everything from low-power sensor networks to the most demanding operations like voice encoding, music streaming, and MP3 decoding. The ESP32-D0WDQ6 chip\* is at the heart of this module. The embedded chip is made to be scalable and adaptable. The CPU clock frequency can be adjusted from 80 MHz to 240 MHz, and there are two CPU cores that can be separately regulated. The chip also includes a low-power co-processor that can be used instead of the CPU to save power while performing tasks that don't require a lot of processing power, such as peripheral monitoring. Capacitive touch sensors, Hall sensors, SD card interface, Ethernet, high-speed SPI, UART, I2S, and I2C are just a few of the peripherals integrated inside the ESP32. The ESP32 can transmit data at up to 150 Mbps. The module's integration of Bluetooth®, Bluetooth LE, and Wi-Fi ensures that it can be used for a wide range of applications and that it is all-around: using Wi-Fi allows for a large physical range and direct connection to the Internet via a Wi-Fi router, while using Bluetooth allows the user to connect to the phone or broadcast low energy beacons for detection.

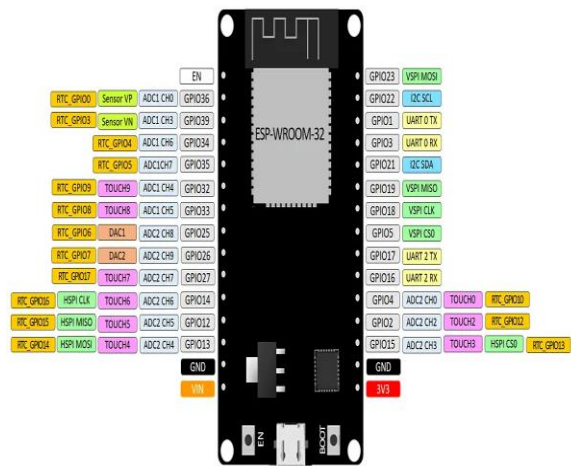

Figure 7. Esp32 Pin Diagram

### 3.6 Light Emitting Diode

Simply put, a diode is a light-emitting diode. When the diode is forward biased, the electrons and holes move quickly across the junction, constantly combining and removing one another. The electrons merge with the holes as they transition from n-type to p-type silicon, and then they vanish. As a result, it stabilises the entire atom and provides a small burst of energy in the form of a tiny packet or photon of light.

### 3.7 Relay Module

The 2-Channel 5V Relay Module is a relay interface board that may be controlled directly by a variety of microcontrollers, including Arduino, AVR, PIC, and ARM. The relay is controlled by a low-level triggered control signal (3.3-5VDC). The typically open or ordinarily closed contacts are operated when the relay is triggered. It's commonly found in automatic control circuits. Simply put, it's an automatic switch that uses a low-current signal to operate a high-current circuit. VCC power to the system. 5V relay signal input voltage range, 0-5V. In the power supply, there is a JD-VCC relay. Shorting JD-VCC and VCC is possible.

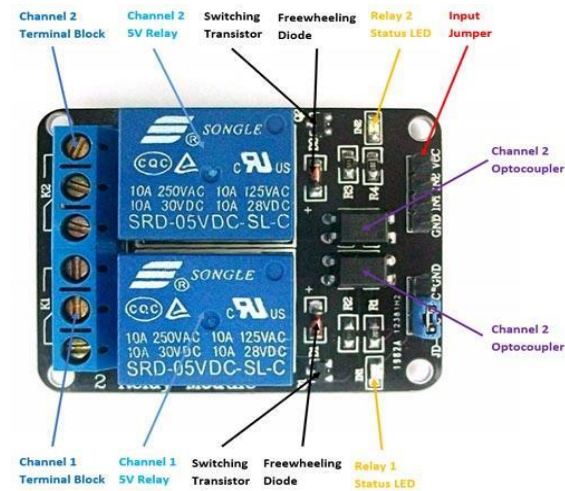

Figure 8. Relay Module (2 Channel)

### 3.8 Android Platform

Android phones are sophisticated mobile computers that are becoming increasingly popular in the world of smart phones [14]. Because of their tremendous capabilities and open architecture, as well as the fact that they are based on the Java programming language, they are becoming increasingly popular among software developers [14]. The Bluetooth gadget is used to communicate between the robot and the cell phone

or mobile. The robot is equipped with a Bluetooth device (HC-05) that can both receive and broadcast data from a mobile device [14].

## 4. RESULTS

When the gas sensor detects a leak, it sends a signal to the controller, which then notifies the user of the leak and activates the buzzer, LED, and exhaust fan to exhaust the gas from the room. When the Flame Sensor detects a fire, it sends a signal to the controller, which notifies the user of the fire detection and activates the buzzer, LED, and water sprinkler to spray water all over the room to reduce the fire's spread. The Controller operates electrical appliances in accordance with the user's commands. The user can control (ON/OFF) the appliances in the house using the Blynk GUI interface. Google Assistant can also be used to operate the appliances.

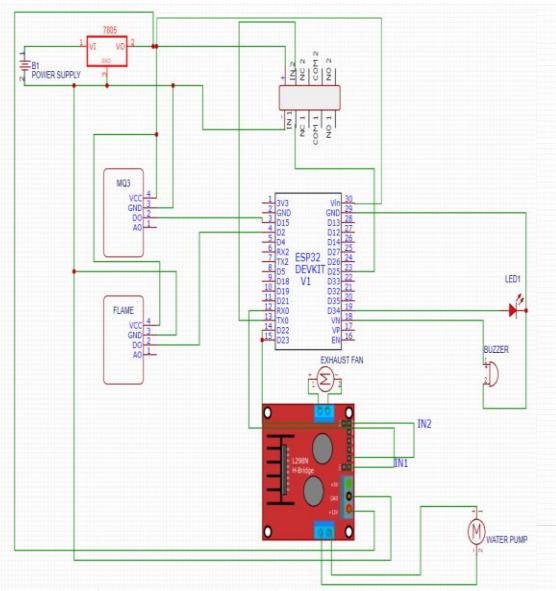

Figure 9. Schematic Diagram



Figure 10. Initial Stage

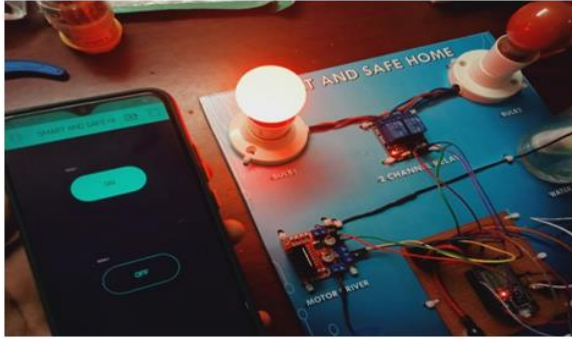

Figure 11. Output when BULB 1 is ON



Figure 12. Output when BULB 2 is ON



Figure 13. Output when both BULB's are ON



Figure 14. Output when both BULB's are OFF

## 5. CONCLUSION

The main goal of a home automation and security system is to allow users to operate various home appliances using an Android application on their phones. It has been determined that wireless technology is used in all home automation and security systems. Home automation solutions based on ESP32 and Android have been used to make it easier for individuals to control their home appliances and to give safety measures. Different home automation strategies using ESP32 and Android are shown along with their design, implementation, and flowcharts, allowing for a clear understanding of their advantages and disadvantages. The goal of this Internet of Things project is to create a smart wireless home security and safety system. The controller, which is presently being built as a prototype for this project, continuously senses the sensors and takes the necessary action in the event of a home security breach. The Controller then controls the relays depending on commands received via the Internet from the User in the case of home automation. The Internet of Things (IoT) is a concept that envisions real-world items (things) being connected and monitored remotely over the Internet.

## 6. FUTURE SCOPE

Home automation has become a reality because to the development of numerous automation technologies that incorporate IoT and AI. With just a single command of spoken instructions, one can complete multiple tasks. These technologies can be utilised to create a fully functional home automation system and control smart home devices such as lighting, thermostats, and appliances. In the near future, many new technologies may become part of everyday life at home:

*Integration of Smart home devices:* Voice and Smartphone commands can be used to operate modest household appliances. All of the tech behemoths are collaborating in the realm of IoT to improve home automation devices. In the not-too-distant future, homes will be equipped with IoT gadgets that will make your daily tasks go more smoothly and accurately.

*Smart spaces outside homes:* Smart parking will use sensors to determine whether or not parking is

available. Camera surveillance is possible, and parking facilities and security can be given using artificial intelligence and computer vision. It would be a more efficient and smoother procedure, and it would serve as a model for other smart systems to follow. Sensors can also be used to automate streetlights, making them more efficient for the people who live nearby.

*Development of smart appliances:* With the advancement of technology, items such as televisions, refrigerators, and even mirrors are becoming smarter. The smart mirror should not only serve as a face video, but also as a tool for other duties such as music listening and other similar activities. Televisions have become a significant source of entertainment and can also be utilised for social networking. The refrigerator has been modified so that it can detect the outside temperature and adjust its operation accordingly.

#### REFERENCE

- [1] Abhinav Singh and Manik Dalal, "Design of an Internet of Things Based One to One Replacement Smart Switch", 2021.
- [2] Sadi Mahmud, Safayet Ahmed, Kawshik Shikder, "A Smart Home Automation and Metering System using Internet of Things (IoT)", IEEE, International Conference on Robotics,Electrical and Signal Processing Techniques (ICREST), 2019, pp.451-454
- [3] L. Atzori, A. Iera, and G. Morabito, "The internet of things: A survey," *Comput. Netw.*, vol. 54, no. 15, pp. 2787–2805, 2010.
- [4] S.D.T. Kelly, N.K. Suryadevara, and S.C. Mukhopadhyay, "Towards the Implementation of IoT for Environmental Condition Monitoring in Homes", IEEE, Vol.13, pp. 3846-3853, 2013.
- [5] N. Singh, S. S. Bharti, R. Singh, and D. K. Singh, "Remotely controlled home automation system", *Advances in Engineering and Technology Research (ICAETR)*, 2014 International Conference on. IEEE, 2014.
- [6] Brown, Eric (13 September 2016). "Who Needs the Internet of Things?". *Linux.com*. Retrieved 23 October 2016.
- [7] Kumar Mandula, Ramu Parupalli, CH.A.S.Murty, E.Magesh, and Rutul Lunagariya, "Mobile-based Home Automation using the Internet of Things (IoT)," 2015 International Conference on Control, Instrumentation, Communication and Computational Technologies (ICCICCT), pp. 340–343, 2015.
- [8] Ahmad Bilal Zia, Kshamta Chauhan, " A Research Paper on Internet of Things based upon Smart Homes with Security Risk Assessment using OCTAVE Allegro", *International Journal of Engineering Research & Technology (IJERT)*, Vol. 9 Issue 06, June-2020, pp.940-948.
- [9] Malche, Timothy, and PritiMaheshwary. "Internet of Things (IoT) for building smart home system." 2017 International Conference on I-SMAC (IoT in Social, Mobile, Analytics and Cloud)(I-SMAC). IEEE, 2017.
- [10] Gabhane, Mrs Jyotsna P., MsShradhaThakare, and Ms Monika Craig. "Smart Homes System Using Internet-of-Things: Issues, Solutions and Recent Research Directions." *International Research Journal of Engineering and Technology (IRJET)* 4, no. 5 (1965): 1969.
- [11] V. Karthik Kumar, P.Vamshi Krishna Rao, " Multiple Motion Control System of Robotic Car Based on Iot to Produce Cloud Service", *International Journal of Management, Technology and Engineering*, Volume 8, Issue IX, SEPTEMBER/2018 Page No:1901-1905.
- [12] D. Priyanka, V. Karthik, " Wireless Surveillance Robot with Motion Detection and Live Video Transmission and Gas Detection", *International Journal of Scientific Engineering and Technology Research*, Vol.04,Issue.17, June-2015, Pages: 3099-3106.
- [13] Amulapuram Srilatha,Karthik Kumar, " Implementing Intelligent Traffic Control System for Congestion Control and Stolen Vehicle Detection", *International Journal for Innovative Engineering and Management Research*, Volume 06, Issue 08, 2017, Pages: 266– 273.
- [14] R. Suprem, V. Karthik Kumar, " Design and Implementation of a Self Balancing Mobile Robo", *International Journal of Research*, " Volume 04 Issue 01 January 2017, pp.1046-1049