

IoT based Home Automation System using Augmented Reality

Aaditya Auti¹, Bharat Kolekar², Saylee Surve³, Tejas Lad⁴, Prof. Shrikrishna Patil⁵

^{1,2,3,4}Student, Rajiv Gandhi Institute of Technology, Mumbai

⁵Faculty, Rajiv Gandhi Institute of Technology, Mumbai

Abstract— This project presents a low-cost and flexible home control and environment monitoring system. The work mainly concentrates on IOT based home automation using Augmented Reality acting as GUI between different home appliances based on wireless home automation system using IOT helps us control basic home appliances automatically by using smartphones. When it comes to our house, this concept can be aptly incorporated to make it smarter, safer, and automated. The leverage obtained by preferring this system over similar existing systems is that the alerts and the status sent by the Wi-Fi-connected microcontroller managed system can be received by the user on his phone from any distance irrespective of whether his mobile phone is connected to the internet. The microcontroller used in the current project is the ESP32 for accessing and controlling devices and appliances remotely. Lastly, Augmented Reality implementation in this project brings users executing direct interactions to manipulate all objects in the surrounding world. Thus, this project presents an idea or a concept for home automation using ESP32 with Blynk App, Augmented Reality, and a switch to control four Relays with and without internet.

Index Terms— Augmented Reality (AR), Blynk Application, ESP32, IOT, Relay, Unity, Wi-Fi.

I. INTRODUCTION

Home automation is become more beneficial because of its safety and security. Nowadays, home automation become more advance and precise to monitor all home appliances.[1] Home automation systems become energy efficient and highly approachable smart home techniques. It involves basic features to maintain user satisfaction and comfort. Modern society wants a safe, economic, comfortable, and convenient life ideal for every family. Home automation is a very promising area. Its main benefits range from increased comfort and greater safety and security to the more rational use of energy and other resources, allowing for significant savings. There are certain issues involved in the design

of a home automation system. The system should be scalable so that new devices can easily be integrated into it.[1]

The alerts and the status of the IoT system can be accessed by the user from anywhere even where Internet connectivity may not be readily available since the mobile phone doesn't need to be connected to the internet only the board is required to have access to Wi-Fi. The difficulty faced by current home security/surveillance systems in providing information about the situation to users while being away from home is tried to overcome in this project.

This Project employs an embedded SoC ESP32 for accessing devices and appliances remotely. People's expectations regarding automation and security have changed to a large extent over time due to the advancement of technology and services. different automation systems over time tried to provide an efficient, convenient, and safe way for inhabitants to access their workplace. Many existing systems still use Bluetooth modules instead of Wi-Fi modules so the area of operation is greatly reduced. Augmented Reality (AR) implementation in this project brings users executing direct interactions to manipulate all objects in the surrounding world.

II. LITERATURE SURVEY

A. IOT based smart home automation using Sensor node.

Author: H. Singh, V. Pallagani, V. Khandelwal and U. Venkanna

Methodology and Principle Proposed: The Arduino is connected to the Bluetooth module; all the appliances can be controlled using the Arduino but it needs to be within a small distance for it to connect to the Bluetooth.^[1]

Outcome: Since the Bluetooth module is used, the range at which the home appliances can be controlled is reduced.

B. Bluetooth Based Automation System.

Authors: Jolan Baccay Sy, Shaik Irfan

Methodology and Principle Proposed: By using this method, home appliances can be controlled to avoid the danger of electric shock and convenience for users. The Bluetooth client was tested on different android phones from different manufacturers, and its works based on its desired functions.^[2]

Outcome: This system gives the best solution to eliminate manual switching. By using this method, home appliances can be controlled to avoid the dangers of electric shock and convenience for users.

C. Voice Controlled home automation system.

Author: P.J. Rani, Jason Baktha Kumar

Methodology and Principle Proposed: The devices connected to the Arduino board can be controlled by voice commands, eliminating the need to control using the application interface.^[3]

Outcome: Since a user-defined NLP algorithm is used, there can be times when the assistant is not able to recognize your commands properly.

D. A low-cost Automation System.

Author: N. Vikram, K. S. Harish, M. S. Nihal, R. Umesh, A. Shetty, and A. Kumar

Methodology and Principle Proposed: The system can be controlled directly from the Wi-Fi module which eliminates the need of using an Arduino board, the command can directly be provided by the user to the module to control the appliances accordingly.^[4]

Outcome: Since the equipment that is used is low cost, there can be numerous occasions when you are encountered errors or technical difficulties.

E. IoT-based smart security and home automation system.

Authors: Ravi Kishore Kodali, Vishal Jain, Suvadeep Bose, and Lakshmi Boppana

Methodology and Principle Proposed: This IoT project focuses on a wireless home security system that sends alerts to the owner by using the Internet via a Microcontroller.^[5]

Outcome: The prototype can be used in the following two ways: As a smart security system and as a smart home automation system

F. Home automation System-Electronics Controlled via Bluetooth.

Authors: N. Sriskanthan, F. Tan, A. Karande

Methodology and Principle Proposed: The objective of this proposal was to develop a home automation system that was based on Bluetooth, Microcontroller, Serial Communication RS232.^[6]

Outcome: In this system, the error detection and correction facility are only handled at the Bluetooth level. A similar facility can be developed at the application level. Also, some security measures to avoid interference of neighboring home automation systems can be incorporated into the application.

G. Arduino-Based Home Automation System Using Android Application.

Author: Md. Wasif Bin Hafiz

Methodology and Principle Proposed: Smart Home System designed and created by utilizing WLAN network based on Arduino microcontroller.^[7]

Outcome: The system design and architecture were discussed, and the prototype presents the basic level of home appliance control and remote monitoring has been implemented. Finally, the proposed system is better from the scalability and flexibility point of view than the commercially available home automation systems.

H. Artificially Intelligent Home Automation System Based on Arduino

Authors: Rituparna Halder, Susmit Sengupta, Sudipta Ghosh, Debasish Kundu

Methodology and Principle Proposed: It gives a basic idea of how to control various home appliances and provide security using Arduino Uno and MATLAB GUI.^[8]

Outcome: This project uses low-cost off-the-shelf components and is based on Visual Basic and Arduino platforms which both are FOSS (Free Open-Source Software). So, the overall implementation cost is very cheap and is affordable by a common person.

III. PROBLEM STATEMENT

- (1).There is a great energy crisis in our country. Moreover, we often forget to switch off our home appliances due to a hectic schedule which results in high energy bills.
- (2).Home automation is all about the management of your home and daily life. You can remotely control lights and other home appliances by turning off them when not in use. Also, day by day we have to develop and upgrade our controlling access and types of control protocols.
- (3).Physically disabled or handicapped people are not able to move much from one place so for them, it is very difficult to access regular domestic appliances. For them, it is essential to develop a system that requires less human interaction.
- (4).The benefits of home automation typically fall into a few categories, including savings, safety, convenience, and control. Additionally, some consumers purchase home automation for comfort and peace of mind.
- (5).Smart home automation systems can save electricity as well as save energy, cutting utility costs over time. Some home automation technologies monitor water usage too, helping to prevent exorbitant water bills.
- (6).Many home automation technologies can make a place safer than before. Consumers purchase these devices because they want to make their homes safer and more secure Automated lighting helps people to recover from their mistakes. If anyone forgets to turn off the lights, can turn it off with the help of an automation system and with less work.
- (7).People choose smart home devices to better control functions within the home. Connected devices can also help create a comfortable atmosphere. They provide intelligent and adaptive lighting, the sound which can all help create an inviting environment.

IV. OBJECTIVE

This project presents an idea or a concept for home automation using ESP32 with Blynk App, Augmented Reality, and a switch to control four Relays with and without internet. With this IoT-based smart home system, the ESP32 is connected with Wi-Fi. It can monitor the real-time feedback of the relays in the Blynk app. If Wi-Fi is available the ESP32 will automatically connect with Wi-Fi and indicate on PCB. The door Lock will be controlled by using the

R305 Fingerprint sensor along with ESP32. It will help users to maintain full authenticity and security. IoT and AR can be complementary to each other as AR offers a convenient and intuitive way for users to visualize and interact with IoT objects and their associated data. Our Mobile App uses a standard AR-enabled IoT service, here the user finds and connects to the IoT device and the app shows an AR-based control interface.AR interaction for home appliances refers to device control to exchange with the attached actuators in the real space. This technique expresses the situations where the user can handle direct interactivity in terms of the physical devices. Control monitoring system for accessing and controlling devices and appliances remotely using Smartphone application and Internet. While using this technology the system improves the living standard at home, reduces human effort and human error, is energy efficient and time-saving, and thus makes a smart home.

V. WORKING PRINCIPLE

In this project, we will design a simple home automation project using simple components using which different electrical appliances can be switched on or off. The project is based on ESP32 and commands are sent via Augmented Reality (Blynk App), which controls the relay operation of the project. This project presents an idea or a concept for home automation using ESP32 with Blynk, Augmented Reality, and manual switch to control 4 relays with and without internet and monitor the real-time feedback in the Blynk app. Automation of devices has a wide scope for this generation as well as in the forthcoming generation.

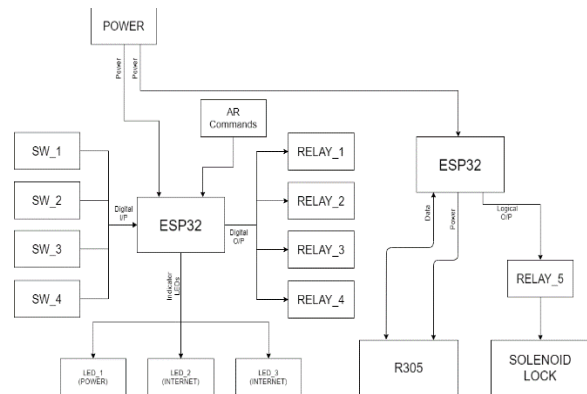

Fig I: - Block Diagram of Proposed System

This proposed system consists of Android mobile in using ESP32 with Blynk app, Augmented reality & Manual control relays. We are using Wi-Fi technology to monitor the device because of its accuracy, high range, and instant connectivity. With this ESP32 project. It can control 4 home appliances from the smartphone, Augmented reality application, and manual switches. If there is no internet available still it can control the relay module from the augmented reality application and manual switches. With this IoT- based smart home system, If the ESP32 is connected to Wi-Fi then it can also monitor the real-time feedback of the relays in the Blynk app. If the Wi-Fi is available the ESP32 with automatically connect with the Wi-Fi.

This project aims to control different home appliances using a smartphone. After making circuit connections and obtaining PCBs then upload the program to ESP32 using a micro-USB type data cable which also powers up ESP32. When the power is turned on, the connection LED on the ESP32 starts and is ready to use. We need to start the “BLYNK” app on our smartphones and get connected to it. If the pairing is successful, the LED becomes stable. Now, in the app, we need to set different keys for different loads and their corresponding value that must be transmitted when that key is pressed.

VI. METHODOLOGY DEVELOPED

AR (AUGMENTED REALITY)

AR is an enhanced version of reality created by using technology to overlay digital information onto a live camera feed. In simpler terms, AR allows digital content to look like it is part of the physical world. visual design is the appearance of the developing application that engages the user. To improve the graphic interface elements and user interaction, developers may use visual cues to inform the user what elements of UI are designed to interact with and how to interact with them.^[9] Since navigating in an AR application may appear difficult and seem frustrating, visual cue design can make interactions seem more natural Every AR system comprises three components - Hardware, Software, and the Application.

IOT (Internet of Things)

IoT enabled home or a Smart home is a wireless smart

control and operation of all home appliances like lights, fans, heaters, air conditioners, refrigerators, washing machines, and other such appliances. When these devices are connected to the internet, they are a part of the Internet of Things.^[10] The backbone of this automation system is a basic (SoC) System on Chip, connected to the internet via USB serial or ESP32 WIFI Module. Models can be integrated as and when required and also to ease human efforts.

VII. CONCLUSION

In this proposed work, the system designed an IoT-based smart home automation system using augmented reality technology. The result part, clearly shows that the system is useful to provide easy human access and integrity, power-saving capabilities, and power to control any appliances from anywhere. By implementing this project, the unwanted wastage of power consumption can be reduced, and also manual work is reduced.

ACKNOWLEDGMENT

It has been a great opportunity to gain lots of experience in real-time projects, followed by the knowledge of how to design and analyze real projects. I would like to express my gratitude and appreciation to all those who gave us the possibility to complete this project. Special thanks to the laboratory in charge for the efforts they did to provide us with all useful information and make the path clear to implement all the education periods in real-time project design and analysis. We were grateful to Prof. Shrikrishna D. Patil, for her timely support. In addition, we would like to express our sincere appreciation to ours.

REFERENCES

- [1] H. Singh, V. Pallagani, V. Khandelwal and U. Venkanna, "IoT based smart home automation system using sensor node," 2018 4th International Conference on Recent Advances in Information Technology (RAIT), Dhanbad, 2018, pp. 1-5.
- [2] Jolan Baccay Sy, Shaik Irfan, “Bluetooth Based Automation System Using Android App,” International Journal of Engineering Research and Technology. ISSN 0974-3154, Volume 13, Number 12 (2020), pp. 5190-5195.
- [3] P.J. Rani, Jason Baktha Kumar, “Voice-controlled home automation system using Internet of Things

- (IoT)," 2017 Third International Conference on Science Technology Engineering & Management (ICONSTEM)
DOI:10.1109/ICONSTEM.2017.8261311.
- [4] N. Vikram, K. S. Harish, M. S. Nihal, R. Umesh, A. Shetty, and A. Kumar, "A Low- Cost Home Automation System Using Wi-Fi Based Wireless Sensor Network Incorporating Internet of Things (IoT)," 2017 IEEE 7th International Advance Computing Conference (IACC), Hyderabad, 2017, pp.174-178.
- [5] N. Kushiro, S. Suzuki, M. Nakata, H. Takahara, and M. Inoue, "Integrated residential gateway controller for home energy management system," in IEEE Transactions on Consumer Electronics, vol.49, no. 3, pp. 629-636, Aug. 2003.
- [6] Ravi Kishore Kodali, Vishal Jain, Suvadeep Bose, and Lakshmi Boppana, "IoT Based Smart Security and Home Automation System," International Conference on Computing, Communication, and Automation (ICCCA2016).
- [7] N. Sriskanthan*, F. Tan, A. Karande, "Bluetooth based home automation system," School of
- [8] Computer Engineering, Nanyang Technological University, Nanyang Avenue, Singapore, Singapore 639798.
- [9] Md. Wasif Bin Hasif, "Arduino Based Home Automation System Using Android Application," DO - 10.13140/RG.2.2.20219.03360.
- [10] Rituparna Halder, Susmit Sengupta, Sudipta Ghosh, Debasish Kundu, "Artificially Intelligent Home Automation System Based on Arduino as the Master Controller," The International Journal of Engineering and Science (IJES), ISSN (e): 2319 – 1813 ISSN (p): 2319 – 1805.
- [11] <https://www.ncbi.nlm.nih.gov/pmc/articles/PMC6806197/>
- [12] <https://www.ncbi.nlm.nih.gov/pmc/articles/PMC7374396/>
- [13] <https://techiesms.com/iot-projects/internet-and-manual-home-automation-using-blynk/>