

Implementation of Beam Forming using QRD-RLS Adoptive Algorithm for Active Phased Array Radar

M.C. Narasimhamurthy¹, G V Jayaramaiah²

¹Technical Officer, LRDE, DRDO, Ministry of Defence, Govt of India, Bengaluru, India

²Professor, Dean R&D, Head of EEE Department, Dr AIT, Bengaluru, India

Abstract— Systems like radiolocation receiver that are unit designed in order to receive spatially propagating signals which typically encounter the presence of interference signals. If the required signal and intruding signal occupy identical band, then temporal filtering is not employed to separate signal from interference. However, the required and officious signal sometimes originates from completely different special locations. This special separation is often exploited to separate signal from interference victimization special filter at the receiver. Implementing a special filter needs process of knowledge collected over a special aperture. Once the special sampling is distinct, the hardware that performs special filtering is termed as beam former. Digital beam forming consists of the special filtering of a proof wherever the section shifting, amplitude scaling, and adding area unit enforced digitally. The thought is to use a machine and programmable atmosphere that processes a proof within the digital domain to regulate the progressive section shift between every antenna part within the array. Digital beam formers ill accomplish reduction of side-lobe levels, interference cancelling and multiple beam operation while not ever-changing the physical design of the phased array antenna. During this case associate degree reconciling filter is employed for the computation.

Index Terms: MIMO, VLSI, Beam forming and AWC.

1.INTRODUCTION

Time varying systems where the performance can be improvised by the computational algorithm for the parametrical adjustment or for weights is coined as a adaptive system. Practically a entity needs to be worked in the unpredictable ambiance i.e. Interpretation of noise or might be due to the improper input signal. Underneath these states of affairs its continually higher to own a versatile system where changes will be done supported the signaling so as to realize higher

performance. Hence forth adaptive filter can be termed as a self-modifying filter where its coefficients can be adjusted in such a way that error function is minimized is defined as adaptive filter. Cost function of the adaptive filter is the substantial difference between the intended signal and the achieved output signal.

2. ENTITY IDENTIFICATION CONFIGURATION OF THE SELF-MODIFYING FILTER

The adaptive system identification is primarily responsible for determining a discrete estimation of the transfer function for an unknown digital or analog system. The same input $x(n)$ is applied to both the adaptive filter and the unknown system from which the outputs are compared. The output of the adaptive filter $y(n)$ is subtracted from the output of the unknown system resulting in a desired signal $d(n)$. The resulting difference is an error signal $e(n)$ used to manipulate the filter coefficients of the adaptive system trending towards an error signal of zero. After a number of iterations of this process are performed, and if the system is designed correctly, the adaptive filter's transfer function will converge to, or near to, the unknown system's transfer function.

2.1 Elimination of the unwanted signal from the self-adaptable entity

The second configuration is the adaptive noise cancellation configuration as shown in figure 2.3 In this configuration the input $x(n)$, a noise source $N_1(n)$, is compared with a desired signal $d(n)$, which consists of a signal $s(n)$ corrupted by another noise $N_0(n)$. The adaptive filter coefficients adapt to cause the error signal to be a noiseless version of the signal $s(n)$. Both of the noise signals for this configuration need to be uncorrelated to the signal $s(n)$. In addition,

the noise sources must be correlated to each other in some way, preferably equal, to get the best results. Due to the nature of the error signal, the error signal will never become zero. The error signal should converge to the signal $s(n)$, but not converge to the exact signal. In other words, the difference between the signal $s(n)$ and the error signal $e(n)$ will always be greater than zero. The only option is to minimize the difference between those two signals.

3. ALGORITHMS FOR ADAPTIVE FILTER

This section comprises of variety of schemes that are conferred to bring out the optimum filter elucidation for the discussed types of error functions. Classification of methodology comprises of algorithms that are adaptative so that it amends the reconciling filter coefficients and there by diminish the allied average of the error present in the entity. Algorithms of the adjustable filter are widely classified into three groups, particularly the approach of least square, the Data Reuse approach, and also the recursive squares approach of algorithms. Every cluster presents precise characteristics of statistical intricacy and also the convergence agility, that contribute to determine the optimum promising result for hand able purpose Computation of Adaptive weight adding is appropriate in abounding advice applications including adaptive beam forming, equalization, pre distortion and multiple-i/o systems. in over determined systems application of these can analytic with numerous equations in abounding cases. Generally recursive least squares (RLS), the simple least mean squares approach (LMS) or the modified approach termed as normalized LMS (NLMS) can be acclimated to seek an associate kind of arrangement of equations. Among them, RLS is a most frequent due to its precisable statistical values and abrupt convergence rate. However, it needs matrix inversion that isn't economical in terms of preciseness and implementation in the hardware. For the robust calculation of the weights the QR decomposition (QRD) method can be applied which are supported RLS that avoids this demerit and results in highly précised conclusions along with the productive architectures. The different approaches for QR decomposition are widely classified as: gram-Schmidt orthogonalization, givens rotations (GR) and

the householder reflections [3]. Due to cohesion and accuracy givens rotation are made favorable. The use of CORDIC elements for the systolic array design that provides an adequate performance employs the givens rotation technique due to its simplicity and is easy to be implemented in the hardware. Hence forth, it is typically used for the hardware implementation. Statistically, it was demonstrated that the modified gram-Schmidt (MGS) methodology is comparable to givens rotations methodology.

Today self-modifying entities have found their method so that they can be applied in various systems were the understand-ability of the arrangement is the essential parameter. algorithms are presented in large numbers to attain the calculated coefficients which alter depending on the complexity of the system.

3.1 LMS: The least mean square. Method (LMS) is the foremost straight forward approach. Due to the simple implementation and decreased utilization of available resources this formula is widely employed. When the system needs to be quickly adjusted to the changes that occur during the occurrence of dynamic medium do not provide optimum performance.

3.2 RLS: When compared it, was accepted that the RLS algorithm is proved to attain better performance with the immediate convergence value than that being provided by the LMS theorem it is also observed that the RLS approach offers quicker convergence and smaller error with relevance the unknown system, at the expense of achieving the additional computations. Adaptation formula minimizes the entire square this concept was derived using the RLS algorithm. Error between the specified signal and therefore the output from the unknown system when compared to that of LMS.

By the usage of the adaptive filtering algorithms the appeal for rapid convergence and smaller MSE level cannot be attained. The most effective alternative is that the block (RLS) algorithm. Block RLS is one of the algorithms that are framed with statistical methods so that it is possible to exhibit optimum performances. The straight forward approach for the calculation of the new weight vector implies the operations on the matrices, that are typically undesired during its implementations on the hardware because the consumption of resource which is increasingly high. The matrix decomposition schemes are coined as method, SVD (singular value

decomposition), QR decomposition and lastly the statistical ways. Issues regarding the least square approach are solved by the QR adaptive algorithm because of its simplicity and ease. As all strategies are repetitive, constant improvement objective for reduction the intricate computations, the improved speed of convergence, and hardness against round-off errors and its advancements. Common issues that come across in several systems is that the presence of echoes and signal which cause disturbance in the system. Declination of the echoes which are present in the system craves the clear-cut information of the impulse response of the strident path, which may be varied instantly.

3.3 QR-DECOMPOSITION AND GIVENS ROTATION

Conventional QRD-RLS Implementation:

The process of conversion to the upper triangular matrix is based on the given input data matrix. this process is done by employing the QR Decomposition in a channeled manner and thereby the weights are generated using the back substitution approach and this is the salvation technique used in the conventional QRD-RLS approach. In the method of back substitution which are used for the calculation of weights is a non-pipelined method were the approach is initiated by employing the last row of the upper triangular matrix and when the data updation is in process the first row is updated first when new value of data enters in. The major demerit of using the system with the back substitution approach is that the time consumption is more because here the last row of matrix needs to be updated. Henceforth the time duration required for the weight generation is more and thereby its optimum to use the inverse approach were the calculation of weights are done through the pipelined flow.

3.4 Inverse QRD-RLS Implementation:

An approach that can be used as alternate to that of conventional approach is inverse QRD approach which is usually depends on the revised value of the inverse cholesky factor is recognized as the inverse QRD algorithm which permits the weight vector calculation lacking the approach of back substitution. In this approach the vector comprising the coefficients are computed for each iteration which achieves the optimum performance. There are two

phases of computation in the conventional QRD approach for the update but these operational steps cannot be resourcefully merged for the pipelined operation on the array.

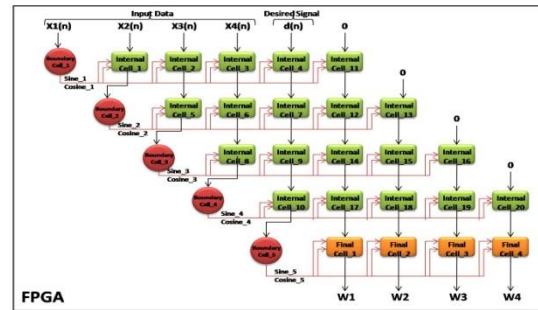

Figure 3.4.1 calculation of vector by employing inverse QRD algorithm.

4. SYSTOLIC ARRAY

The system designed to get higher performance and to attain a meant purpose is thought as special purpose system or application specification system. Since it's designed to perform a specific operation the value of the hardware furthermore because the size area unit reduced and needs of the system of the system area unit understood clearly. Special purpose system are often classified as

- 1) Inflexible and extremely dedicated structure.
- 2) System enabling some programmability and reconfiguration.

Development of special purpose system is cycled to 3 main operations they're shaping the task, design of the system and therefore the implementation of the planning. Architectural problems for special purpose system is outlined as

- 1) Simple & regular style
- 2) Communication & assimilation
- 3) Balancing computation with I/O

4.1 Basic Principle of Pulsation Array

Hence forth the pulsation array is outlined because the tree or the array was the information flows through the process components rhythmically. The example for the pulsation array within the globe is given because the material body, were heart is designed to be a worldwide memory whereas the network of veins is taken into account because the set of process components. Conceptually the computation task may be generally classified as

- 1) Figure certain computation

2) I/O certain computation

Considering the instance of matrix operation wherever every row is increased with columns .here the amount of computation square measure bigger than that of set of inputs and outputs thus it's termed as figure certain computation. Considering second example of matrix operation property were two matrices to be to get the output. Here the computation needed is simply the addition of two components and therefore the overall computation is a smaller amount thus it's termed as I\O certain computation. Speeding is that the vital issue to be thought of throughout the planning of the system. Within the I/O certain computation the information measure of memory goes high because of quick parts and de-interleaved memory. Thus it's not appropriate for operational use. Whereas the computation certain is straightforward and cheap approaches while not the rise in memory information measure. Herewith pulsation array approach is best suited with the figure certain computation. Due to the pipeline ability and standard style this technique has ton of benefits they're declared as

- 1) More cost-effective
- 2) Intensive compatibility
- 3) Use of easy cells for operation
- 4) Multiple use of given input file

4.2 Features of Pulsation Array

- 1) Synchronicity: This can be restricted as synchronous or by asynchronous manner. Here the information is calculated rhythmically and ecumenical clock is employed for the flow of knowledge within the network for synchronous circuits.
- 2) Spatial locality: Every giant system are often broken into a system that comprise of cells and nodes. The live of the division in network is understood as abstraction neighborhood.
- 3) Temporal locality: The communication between the system\cell is feasible once the information is transmitted from one cell to a different. Whereas this communication to happen ought to need a unit delay of time.
- 4) Granularity: Granularity is that the extent to that a system consists of distinguishable items or grains. It will either seek advocacy from the extent to that a bigger entity is branched, or the extent to that contingent of petite indistinguishable entities have

joined along to become larger distinguishable entities.

5. BEAMFORMING

Technique of processing the signal which is termed as Beam forming may be employed to manage the signal directionality neither from the transmission end nor from the reception end on the transducer array. Employing the technique of Beam forming we will be able to direct the maximum signal energy that are transmitted from the clusters of transducers(like radio antennas) in an accepted angular direction. Otherwise the clusters of transducers are calibrated once it receives the signal.

In an exceedingly accepted MIMO technology, some contrasting approach is coined below.

i) Accessible Loop methodology: this concept can be stationed on the inference that the arrangement is 'somehow' aware of the appropriate matrix of beams which are formed without any appropriate knowledge of the user equipment. Appealingly two approaches are stated below.

- a) Employing constant matrix of Beams for the all entire transmission.
- b) Implementing the matrix of beams that alter dynamically even though it is not sustained by the appropriate requirements stated by the user equipment.

ii) Locked Loop methodology: a better approach where appropriate matrix of beams are achieved by the network which is supported based on the distinct description of the user equipment. Stationing on this principle, network broadcasts a definitive signal the user equipment estimates the receiving signal aspects supported by the receiver and records the outcome to Network.

The purpose of beam forming is to exactly align the phases of associate degree incoming signal from completely different components of associate degree array to make a well understood beam in a very specific direction essentially; the signals from every of the weather area unit delayed specified after they area unit summed all of them have constant delay cherish a particular direction. There's a physical geometric delay on the incoming wave front that will increase linearly across the array that is then paid for electronically before being summed.

5.1 Types of beam forming

Beam forming techniques can be broadly grouped into

- 1) Analog Beamforming
- 2) Digital Beamforming

5.1.1 Analog Beamforming:

This approach can work across a large frequency information measure if the signals area unit delayed in time and so summed. Adaptive beamformers distinguish the properties of signals and the intruding signal through the spatial filtering, wherever associate degree array of freelance sensors offer a way of sampling the received signal in area. The sensing element outputs area unit then processed by a transverse filter to supply the beamformer output. The first purpose of the adaptive beamformer is to guard a target signal whereas cancelling associate degree interference signal.

5.1.2 Digital Beamforming:

In beam forming, each the amplitude and part of every antenna part area unit are controlled. In digital beam forming, the operations of part shift and amplitude scaling for every antenna, and summation for receiving, area unit are done digitally. Either all-purpose DSP's or dedicated beam forming chips are employed. Digital process needs the signal from every associate degree and the antenna part is digitized. Since radio signals are higher than shortwave frequencies (>30 MHz) which are too high to be directly digitized at an inexpensive value, the digital beam forming receivers make the utilization of these analog RF translators so there is possible shift in the signal frequency before the ADC. Once the antenna signals are digitized, they're passed to "digital down-converters" that shift the radio channel's center frequency all the way down to zero cycle per second and pass solely the information measure needed for one channel. The components of antenna as a set, analog to digital converters and lastly the translators are shared by large number of beam formers. All RF translators and ADC converters share common oscillators in order that all of them turn out identical part shifts of the signal. inside the digital beam former, all digital down-converters share a clock signal, constant center frequency for particular set and the measure of the information, lastly their digital oscillators area unit which are in-phase so that all part shifts units are

identical. Every ddc's baseband output is increased by the advanced weight for its antenna part, and also the results area unit summed in order to supply the single baseband signal along with the properties of directionality. In order to recover the data from the radiation of the radio signals a rectifier is employed.

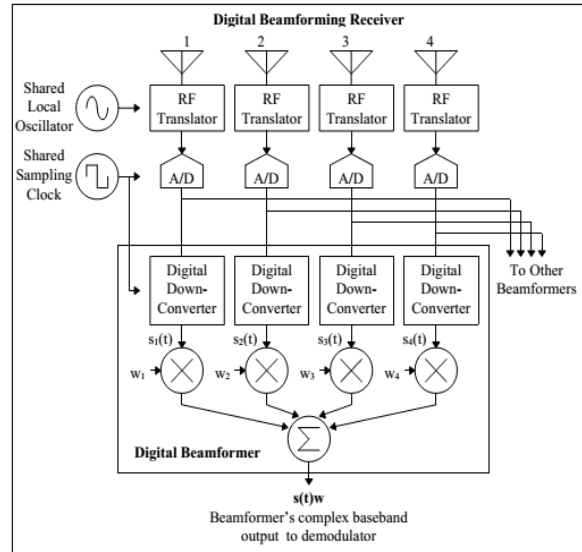

Figure.5.1.2: Digital beamformer structure

5.2 Adaptive Array Antennas

Adaptive antenna technology serves as the initial leading sensible antenna methodology to this point. employing a form of new signal-processing algorithms, the adaptive system takes advantage of its compatibility to adequately find and record the various types of signals so that it can dynamically diminish the interference and enhance the reception of signal at each system such that the gain consistency is increased along with the user placement; henceforth optimum gain is ensured by the system which is adaptive for all the time distinctive, tracking signals, and thereby reducing the busy bodied signals. In The adaptive antenna systems approach the contact in between a user along with base station is in a completely different method, which results in adding a dimension of area. By adjusting to associate degree RF setting because it changes (or the spatial origin of signals), adaptive antenna technology which will dynamically alter the signal patterns to close eternity in order to optimize the performance of the wireless system. Adaptive arrays utilize subtle signal-processing algorithms to unendingly distinguish between desired signals,

multipath, and busy bodied signals and calculate their directions of arrival. This approach unendingly updates it's transmit strategy supported by the changes in each of the required and busy bodied signal locations. The flexibility to trace users with main lobes and interferers with nulls ensures that the link budget is continually maximized as a result neither of the small sectors nor predefined patterns.

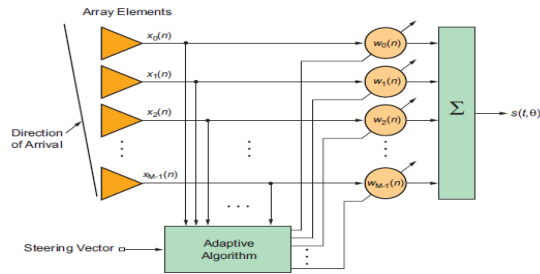

Figure.5.2.1 (a): Adaptive beamformer structure

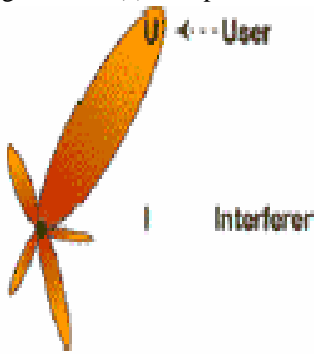

Figure.5.2.2 Adaptive Array Coverage

5.3 Adaptive Beam-Forming Algorithmic Rule

The adaptative algorithmic rule employed in the signal process includes a profound result on the performance of a sensible Antenna system. Though the sensible antenna system is usually known as the area Division Multiple Access, it's not the antenna that's sensible. The operation of the associate degree antenna is to convert electrical signals into magnetic force waves or the other way around however nothing else. The adaptative algorithmic rule is that the one that offers a sensible antenna system with its intelligence. If the associate degree is not up to the adaptative algorithmic rule, the first signals will not be extracted. Different adaptative algorithms were developed for various functions and tasks. The task of the algorithmic rule in a very sensible antenna system is to regulate the received signals in order that the required signals area unit extracted once the

signals area unit combined. Various strategies are employed in the application of associate degree adaptative algorithmic rule. The adaptative QRD-RLS algorithmic rule that produces associated degree is completed for this beamforming within the radars as an application.

Adaptive filters: the different adaptive algorithms are employed in these filters. But here in our design we use the inverse QRDecomposition algorithmic rule.

Complex multipliers: Here two multipliers are used those are In-phase multipliers and the Quadrature phase multipliers. In the In-phase multipliers the multiplication of the real numbers are done while in Quadrature phase the imaginary part of the complex numbers are multiplied.

Summation module: The results of this module are In-phase for the real numbers and Quadrature-phase for the imaginary numbers.

5.3.1 Evaluation and Wave Window:

The representation makes sense for several bits but is mostly confusing for busses or bit vectors. The number format of signals and variables can be changed within the radix settings. There for the signals and variables have to be marked and radix and requested format from the format menu have to be selected. The several bits of vectors can be opened and closed by clicking on and off respectively. The part of the wave forms to be selected using the scroll bars on the right side and below the right column of the wave window.

6. RESULTS

6.1 MATLAB Results

6.1.1. Following is the result of the implementation of adaptive beamforming using conventional QRD-RLS algorithm for 16 element linear phased array radar in MATLAB. Input angle of arrival for desired signal= 40° , Input angle of arrival for interference signal= 20°

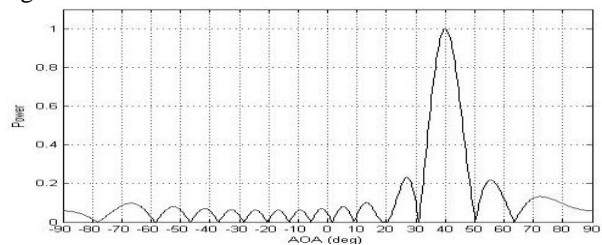

Figure.6.1.1: Beam plot for the 16 element linear antenna array using weights generated by conventional QRD-RLS in MATLAB

6.1.2. Following is the result of the implementation of adaptive beamforming using inverse QRD-RLS algorithm for 16 element linear phased array radar in MATLAB. Input angle of arrival for desired signal= 25° , Input angle of arrival for interference signal= 10°

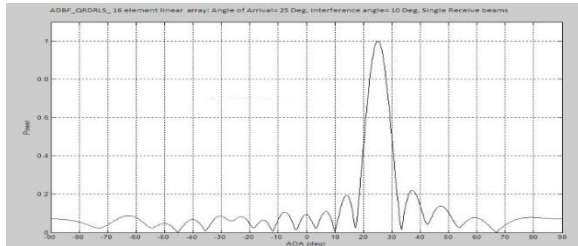

Figure 6.1.2: Beam plot for the 16-element linear antenna array using weights generated by inverse QRD-RLS in MATLAB

6.1.3. Following is the result of the implementation of adaptive beamforming using inverse QRD-RLS algorithm for 16 element linear phased array radar in MATLAB. Input angle of arrival for desired signal= 0° , Input angle of arrival for interference signal= 40° . Number of beams = 9

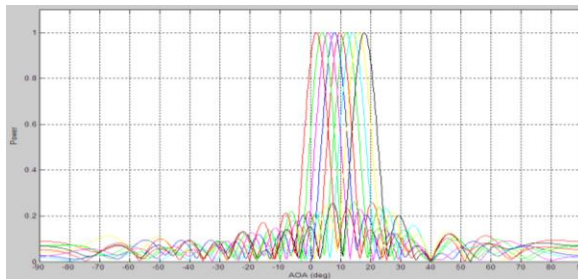

Fig.6.1.3. Linear array of sixteen elements Nine adaptive beams.

6.1.4 Following is the results of the implementation of adaptive beamforming using conventional QRD-RLS algorithm for 16 element planar phased array radar in MATLAB.

Input azimuth angle= 40°
Input elevation angle= 20°

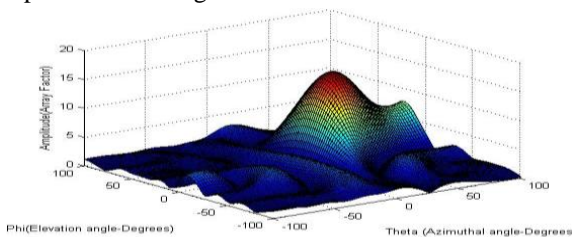

Figure 6.1.4: Beam plot for the 16-element planar antenna array using weights generated by conventional QRD-RLS in MATLAB

7. CONCLUSION & FUTURE SCOPE

Signal processing finds its huge application in modern radars making the system immune to the limitations that the analog methods face. The array signal processor enables the radars to track the changes in continuously varying environment and makes the adaptive beamforming system robust and efficient so that it can be used for tracking multiple targets in very less time.

Realization of array signal processor for phased array radars can be done because of its capability to process the inputs of sixteen element planar array. Calculation of weights that are required for the adaptive beamforming is done adaptively by employing the inverse QR Decomposition algorithm. The implementation of the array signal processor can be done on the Xilinx Kintex 7 FPGA's, which is a customized FPGA board that comprises of three Kintex 7 FPGA. The design employed here is a modular. From the inputs of the sixteen element array we calculate the final weights in order to plot the beam for the achieved values. The calculated final weights are plotted on the PC through MATLAB by exporting the data calculated from the hardware emulator kit through Chipscope. The array signal processor developed can run at frequency of 100MHz and takes around 1 micro seconds for getting set of optimized weights.

REFERENCE

- [1] Farhad Merchant, Anupam Chattopadhyay, Efficient QR Decomposition Using Low Complexity Column-wise Givens Rotation (CGR), proc 2014 27th International Conference on VLSI Design.
- [2] J. G. McWhirter, "Recursive Least Squares minimization using a Systolic Array", Proc. SPIE 431, Real-Time Signal Processing VI, pp. 105-112, 1983.
- [3] Xiaojun Wang, Miriam Leeser, "A Truly Two-Dimensional Systolic Array FPGA Implementation of QR Decomposition", Northeastern University.

- [4] S. Haykin, Adaptive Filter Theory (4th Edition, Pearson, ISBN 978-81-317-0869-9, 2011) pp 4-22.
- [5] Sufeng Niu, Sizhou Wang, Hardware and Software Design for QR Decomposition Recursive Least Square Algorithm (2013) IEEE 978-1-4799-0066-4/13
- [6] Ayman Elnashar, Said Elnoubi Performance Analysis of Blind Adaptive MOE Multiuser Receivers Using Inverse QRD-RLS Algorithm IEEE trans on circuits and systems.