

# Vending Machine

B.V.N.R.Siva Kumar<sup>1</sup>, Kuriseti.Siddhartha Roy<sup>2</sup>, C Bapaiah Naidu<sup>3</sup>, Addanki.John<sup>4</sup>

<sup>1</sup>*Department of ECE, Lakireddy Bali Reddy College of Engineering (A), Mylavaram-521230, Krishna District, Andhra Pradesh, Jawaharlal Nehru Technological University Kakinada*

<sup>2,3,4</sup>*Department of EIE, Lakireddy Bali Reddy College of Engineering (A), Mylavaram-521230*

**Abstract**— Vending Machine as we all knows is a machine which can sell different products which is more like an automated process with no requirement of man handling which we typically required. A machine which dispenses particulars such as snacks, potables to customers automatically. This machine can be made by using Arduino. Framework can be made by using cardboard wastes, springs, stepper motor, IR Detectors. To dispense the item the instructions were given to the stepper motor to run the springs. This medium was programmed and works out into Arduino. The costumer can also elect the needed particulars by touching the products will be allocated into a tray. So that total particulars list will be sent to the customer through communication via message and payment can be done via mobile phone. It's conservation Cost is actually low and we can save time and money. It's a simple medium which can be easily established.

**Index Terms:** Arduino Nano, Servo motor, DC motor and Motor driver, Automation.

## I.INTRODUCTION

Vending a machine is a device that dispenses items or objects consisting of snacks, beverages, alcohol, medicines, and tickets to guests automatically after the client inserts currency or credit into the machine. The first present-day vending machines had evolved in England within the early 20th century and distributed postcards. In this project, the significance of a present-day vending machine is the usage of Arduino has undertaken. The first ultramodern vending machines were introduced in London, England in the early 1880s, allocating cards. The machine turned into built by Percival Everitt in 1883 and shortly got here a wide mark at road stations and submit services, shelling out envelopes, cards, and notepaper. The UK Company was innovated in 1887 in England because the first business enterprise to deal often with the setup and maintenance of vending machines. An automatic vending machine is a

common sight in enterprise centers, malls, airfields, etc. The easy division of products without using pressure is needed. This layout targets to make a corresponding unit, replicating the essential capabilities and enhancing others to suit the variety of this design. The conceptualization of the layout at various ranges is based on being fashions and literature. The nutritive quality of food and libation merchandise vended in dealing machines has been intertwined as a contributing issue to the improvement of an obesogenic meal terrain. The end is to reduce the burden of people working in stationeries as well as guests. This machine also has an intertwined medium which directs people to their destination without any hassle.

## II.LITERATURE REVIEW

The food terrain has simplest current been studied as a critical contributor to the salutary opinions humans make each day; critiques which ultimately affect each short and long-time period health issues. The erected terrain, or the environment we produce for the locations we live, work, shop, and so on, affect the nutrients terrain, which incorporates the outside cues that impact one's meals alternatives and consumption (Sallis & Glanz, 2006).

Generally, the nutrients terrain within the maturity of groups in the U.S. specializes in comfort, fast food, and huge element sizes and neglects fresh fruits and vegetables (2006). A nutrients terrain conducive to healthful eating, where foods similar as low-fat milk, fruits, vegetables, and whole-grain chuck are readily available at an original grocery or comfort store, is much less possibly to be planted in lower-earnings groups.

## III.HARDWARE MODULES

The main components used are:

1. Arduino Nano Board
2. DC motor
3. Servo motor
4. IR sensor

1. Arduino Nano Board

Arduino Nano is cheap, small and breadboard friendly and it can be easy to programmable. This board consists of 8 analog inputs, 14 digital I/O pins. Out of 14 pins, 6 pins are used as PWM output pins. The board is based on ATmega328P microcontroller. Microcontroller is having 28 pin configuration in which there are three ports such as port B, port C and port D. And this board consists of type-B USB port.

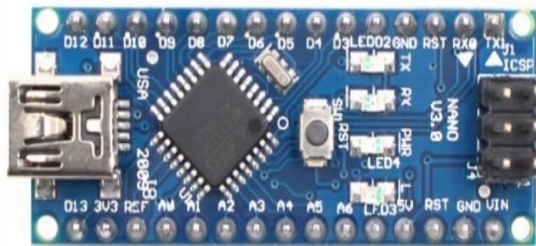

Figure 1: Arduino Nano Board

2. DC motor

DC motor is a rotary electrical machine that converts electrical energy which is in the form of DC into mechanical energy. The main principle of DC motor is based on the Fleming’s left-hand rule. When a conductor is on left side encounters a force in the direction upwards whereas on the other side it encounters force on downwards. Thus, a torque is developed in single direction in DC motors. In this project, two DC motors are used for opening and closing of bridge plates.



Figure 2: DC motor

3. Servo motor

Servo motor is which helps in the toll gates opening and closing based on the signal it gets from IR detector. It basically works on Pulse Width Modulation which means its angle of rotation can be controlled by the duration of pulse as its control pin.

Typically, 1 ms to 2 ms is the range of width of the pulses. Therefore, the servo motor rotates high until 180 degrees and cannot rotate continuously. Servo motor can rotate 90 degrees from its own position to either of its direction. Here two servo motors are used to lift the tollgates.



Figure 3: Servo motor

4. IR sensor

The IR sensor measures the intensity of reflected radiation. The main components of IR sensor are IR transmitter and IR receiver. It works based on when the IR emitter emits the radiation, it reaches the object (target) and some of the radiation reflected back to the IR receiver. If the ship is detected by the sensor, it sends a signal to the arduino nano for opening of the bridge and if the ship is not detected by the sensor, it sends the signal to the arduino nano for closing the bridge.

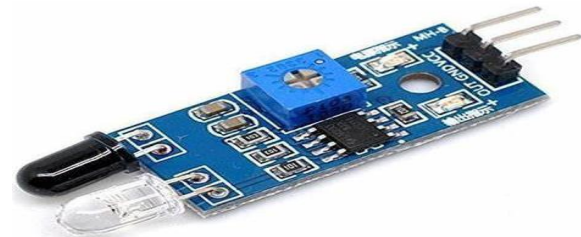
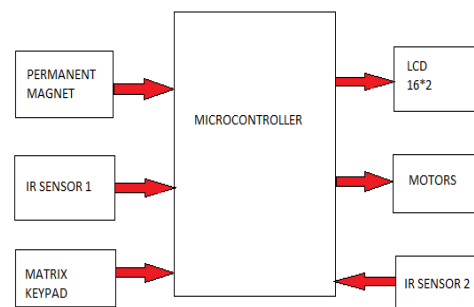
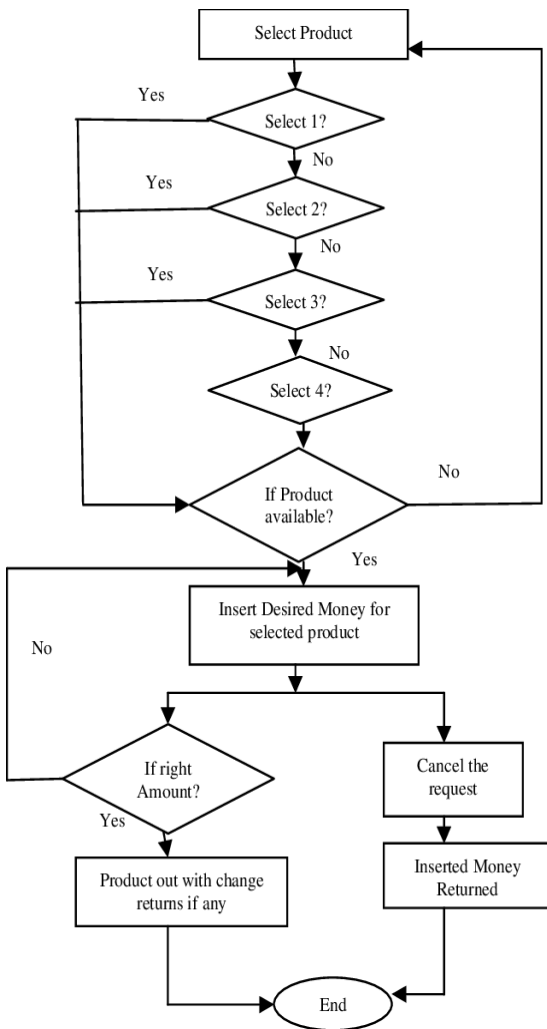

Figure 3: IR sensor

IV.BLOCK DIAGRAM



V.FLOW CHART



VI. WORKING

Mechanical Unit It consists of breakers, gears, shafts which form an integral part of the paper allocating system. The introductory frame for allocating paper has been done using wood, essence. Electronic Unit and Programming IDE It consists of arduino microcontroller which will check for the authenticity by comparing the speed computations with a specific fixed criterion and thereby shoot signals for starting Allocating medium. We make use of introductory generalities of Bedded C language conjoined with Arduino Instruction Set. Electrical Unit The SMPS as well as electrical motors form the electrical factors.

VII.OUTPUT



Figure 4: Output

VIII.CONCLUSION

We presented designing of Arduino based vending machine snack dispenses items. This process able to reduce the man power required for the process and efficiency is increased. We all know that automation is strength of our country. The main objective of this project is to design the automated vending machine to reduce the man power. We successfully implemented a functioning prototype vending machine for snack items. Although dealing machines are being used extensively currently. Having paper allocating machines is essential in premises, services wherein scholars or workers need to stay by long ranges. This type of machine reduces mortal sweats and also provides accurate results.

REFERENCES

- [1] Poon, T. C., Choy, K. L., Cheng, C. K. and Lao, S. I. A Real-Time Replenishment System for Vending Machine Industry.Proceedings of the2010 IEEE Industrial Informatics.July 13-16, 2010. Osaka: IEEE, 209 –213.
- [2] Yokouchi, T. Today and tomorrow of vending machine and its services in Japan. Proceedings of the 2010 IEEE Service Systems and Service Management.June 28-30, 2010. Tokyo: IEEE, 1-5.
- [3] Buck, A. J., Hakim, S., Swamson, C. and Rattner, A. Vandalism of Vending Machines: Factors That Attract Professionals and Amateurs. Proc. Journal of Criminal Justice, 2003. 31: 85-95.