

# Autonomous Car

K.Sasi Bhushan<sup>1</sup>, P.Lakshmi Brahmani<sup>2</sup>, K.Baby Nandini<sup>3</sup>, J.Bala Hemanth Kishore<sup>4</sup>

<sup>1</sup>Associate.Prof, ECE Dept., Lakireddy Bali Reddy College of Engineering Mylavaram, JNTUK

<sup>2</sup>EIE Dept., Lakireddy Bali Reddy College of Engineering Mylavaram, JNTUK

<sup>3</sup>EIE Dept., Lakireddy Bali Reddy College of Engineering Mylavaram, JNTUK

<sup>4</sup>EIE Dept., Institute, Lakireddy Bali Reddy College of Engineering Mylavaram, JNTUK

**Abstract—** The aim of our project is to form a autonomous car. The working is predicated on Arduino micro-controller, motor drivers, a Bluetooth module. Arduino is an open-source hardware (single-board microcontrollers and kits) used for building digital devices. the thought is to first design the Hardware of the Autonomous Car and so code the whole working using our previous knowledge of programming. The code will then be simulated on software (IDE) and later be interfaced with the hardware. The coordination of control unit with Bluetooth gadget is accomplished utilizing a Bluetooth module to catch and skim the voice orders. The controlling remote could be a smart android device with Bluetooth Application. The ultrasonic sensor used will detect the obstacle and stop until it receives next command. We picked this as our project as robotics has become a serious a part of our everyday lifestyle and even have a good scope within the engineering field. It plays an important role within the development of recent technology.

**Index Terms:** Arduino UNO, Servo motor, DC motor and Motor driver, Automation

## I.INTRODUCTION

In this, Autonomous Car project the user will give particular voice commands to the robot by a Ghost remote App installed on the Smartphone. Bluetooth HC-05 receive the commands from Ghost remote App and send that commands to Arduino UNO for controlling the robot car. Arduino UNO will control the movement of the robotic car according to the received voice commands. The robotic car will move forward, backward, right, left and stops according to the voice commands front, back, right, left and stop, respectively.

Speech signals are important signals for communication with human beings. Almost every conversation to interact is done by voice signals only. Sounds and various speech signals that can be

converted into electrical form using a micro phone. Voice recognition is a technology used to convert speech signals into a computer text format. The commands are given by the Ghost remote App on the user mobile is connected to the robot by a Bluetooth HC-05 module.

The main aim of Autonomous car is to receive the commands given by the Ghost remote App. Here, the user should give training to the system, so that the device will able to start understanding the commands. It will be completed by adding the required commands to the device by dumping the code. The use of Ghost remote app is to recognize and respond for the commands, produced by the user which is given as an input to the program.

## II.LITERATURE REVIEW

SMART PHONE CONTROLLED ROBOTS USING ATMEGA328 MICROCONTROLLER Authors: Sapana M. Bramhankar, Aniket R. Yeole, Mukesh P. Mahajan, Monali D. Wani The robot can be controlled by using a remote controller in this project. It will transmit the instructions given by the user for controlling the robot by Bluetooth containing certain aspects like monitoring the motor speed by sending the data to the mobile about the distance and the path covered by the robot from the nearby obstacl.

ROBOT CONTROLLED CAR USING WI-FI MODULE Authors: Vipul Mehta, S. R. Madkar, MaitriParida, Nitin Bhuwania It is a project which is designed to control the robotic car using wireless module by an android application of an android mobile. It can also show that the applications are controlled even in the absence of an android mobile by sending the SMS to the device. This project can change easily by adding a spy camera as well as it

can show the recordings to the user by using Wi-Fi connection.

ROBOT CONTROL DESIGN USING ANDROID SMARTPHONE Authors: Javed Khan, Mrumal. K. Pathak, AarushiKoul, Raunak Varshney, Reshma Kalane It is a project which is designed by simple robot hardware architecture to provide powerful computational android platforms. It presents an evaluation of robots which are controlled by android mobile by moving the robot front, back, right and left by android application.

### HARDWARE MODULE

The main components used are:

1. Arduino UNO Board
2. DC motor
3. Bluetooth Module
4. Ultrasonic Sensor

#### 1. Arduino UNO Board

Arduino UNO is the development board name which has microcontroller ATmega328P mounted on it. ATmega328P microcontroller consists of 28 pins. It has 3 ports those are Port B, Port C and Port D. Port B and Port D contains 14 digital pins and Port C contains 6 analog pins. A microcontroller is an IC device which performs all the tasks, it is used to hold the pins for easy use and for uploading code, for this purpose Arduino UNO board is made

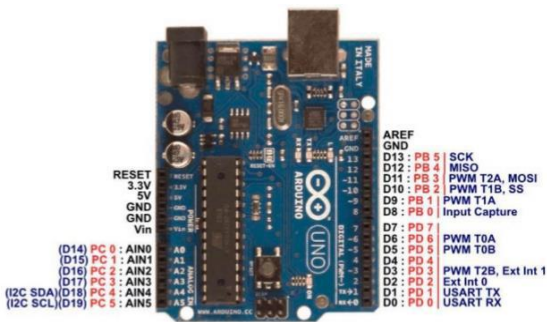


Figure 1: Arduino Nano Board

#### 2. DC motor

DC motor is a rotary electrical machine that converts electrical energy which is in the form of DC into mechanical energy. The main principle of DC motor is based on the Fleming's left-hand rule. When a conductor is on left side encounters a force in the

direction upwards whereas on the other side it encounters force on downwards. Thus, a torque is developed in single direction in DC motors. In this project, two DC motors are used for opening and closing of bridge plates.



Figure 2: DC motor

#### 3. Bluetooth Module

This component is a Serial Port Protocol Bluetooth module. It is mainly designed for serial Wi-Fi connection arrangement. It can provide switching between slave and master mode that means it can be used for transmitting or receiving Serial port data Bluetooth module which is a fully qualified Bluetooth V2.0+EDR 3Mbps Modulation having 2.4GHz frequency and base band. There are two work roles those are slave and master at the programmed connection work mode. This HC-05 is used to communicate between android phone and microcontroller. There are so many android applications which are already available and that makes the process easier. This Bluetooth module is used to communicate by the help of USART at 9600 baud rate. This is very easy to interface with the microcontroller which can supports USAR

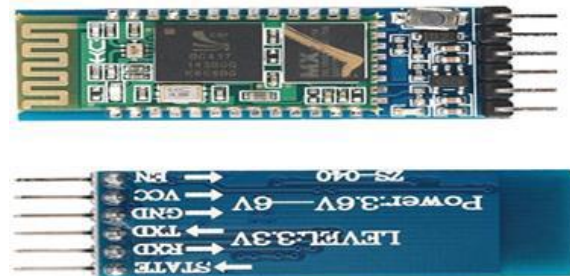


Figure 3: Bluetooth Module

#### 4. Ultrasonic Sensor

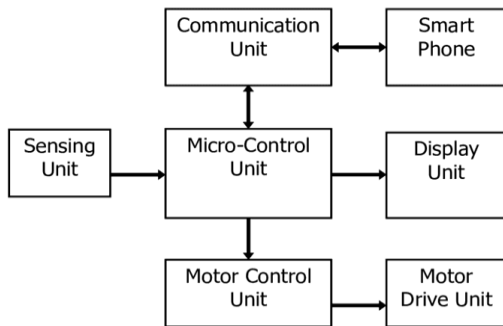
The HC-SR04 Ultrasonic detector using which the Robot can automatically descry the handicap in front of it's detected and distance between both realities. It's done by noting the time taken by ultrasonic swells

transmitted from the ultrasonic detector and entering the echo swells after hitting any handicap face. Hence, the distance between an object and the robotic vehicle will be calculated using the formula.

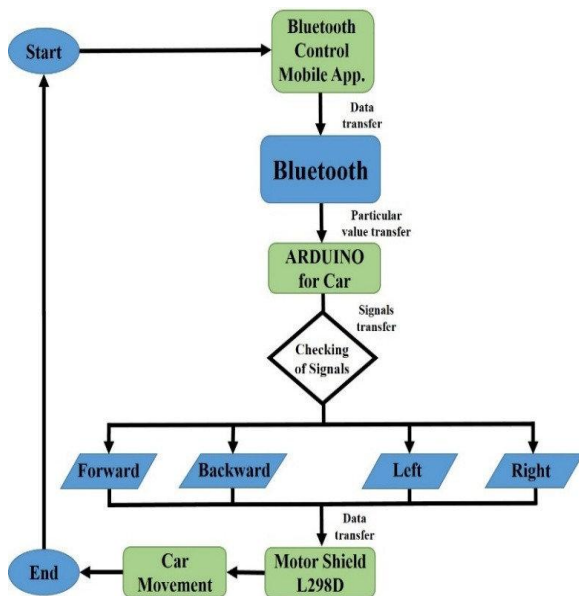


Figure 3: Ultrasonic Sensor

### III.BLOCK DIAGRAM



### IV.FLOW CHART



### V. WORKING

In this Autonomous Car the user will give particular voice command to the robot by a Ghost remote application which is installed on the smart phone. Speech acknowledgement is transmitted by the Ghost remote application which convert voice command into text and that text is send to the HC-05 Bluetooth module in bit by bit manner. That text will get decoded by the Arduino UNO ATmega328P microcontroller. The Arduino UNO will compare that text with dumped program if the text gets matched it sends that instruction to L293D Motor Driver. That Motor Driver can control 2 DC motors at a time to drive in the particular direction. The Bluetooth Module is used to receive the instructions from the user.

### VI.OUTPUT



Figure 4:Output

### VII.ADVANTAGES

- Size of the robot is small, and less space is required for it.
- Power consumption is less.
- We can operate the robotic vehicle by using Wi-Fi connection.
- Accidents will not be done by improper driving, also helpful for old and physically handicapped people.

### VIII.CONCLUSION

Autonomous Car system shows how the android mobile will be used as a remote controller for robots and for various embedded systems by the Bluetooth technology. This robot is operated by the

Smartphone. The wireless network, is used to communicate between Smartphone and robot it is simple way to operate the robot. This is used in many applications where humans cannot go. This is operated by voice commands and if objection occurs it stops and it waits for commands. Autonomous car is to receive the commands given by the Ghost remote App. Here, the user should give training to the system, so that the device will able to start understanding the commands. It will be completed by adding the required commands to the device by dumping the code. The use of Ghost remote app is to recognize and respond for the commands, produced by the user which is given as an input to the program. This is used in many applications.

#### REFERENCE

- [1] "Smart Phone Controlled Robot Using ATmega328 Microcontroller", SO 3297: 2007 pg: 352-356 by Aniket R.
- [2] "voice control Robot Using Android Application", Volume:4, ISSN:22775668 pg:332-337 by R.M.Narayana, Harsha Chapala
- [3] Heidi Monson "Bluetooth technology and implementation", John Wiley & Sons, 1999.
- [4] HarshaDange, "Smart Phones Andriod Operated Robot" pg: 551-567.
- [5] "ROBOT CONTROL DESIGN USING ANDROID SMARTPHONE", 2 FEB 2015, ISSN : 2347-5471 by Mrumal.K.
- [6] "ANDROID CONTROLLED SURVEILLANCE ROBOT WITH OBSTACLE DETECTION USING ARDUINO" by RahulDogra