

# 4G GSM Based Smart Information System for Lost ATM Cards

S. Rohan Khanna<sup>1</sup>, B. Rajesh Goud<sup>2</sup>, G. Akhil<sup>3</sup>, Bijaya Kumar Muni<sup>4</sup>

<sup>1,2,3</sup> Student, J B Institute of Engineering and Technology (JBIET), Hyderabad

<sup>4</sup> Assistant Professor, J B Institute of Engineering and Technology (JBIET), Hyderabad

**Abstract—** This project is aimed to design a security system for banks using wireless technology GSM. A GSM modem provides the communication interface. It transports device protocols transparently over the network through a serial interface. A GSM modem is a wireless modem that works with a GSM wireless network. This GSM Modem can accept any GSM network operator SIM card and act just like a mobile phone with its own unique phone number. Advantage of using this modem will be that you can use its RS232 port to communicate and develop embedded applications. Applications like SMS Control, data transfer, remote control and logging can be developed easily. The modem can either be connected to PC serial port directly or to any microcontroller. This project is designed on micro controller, which is interfaced with a GSM modem to send the message about the lost card details to the user. Here how it works: In this project we interface the ATM machine to GSM modem, whenever any user loses his ATM card, he puts a complaint in the bank just by sending message, When this lost card is placed in the ATM center the card details will be immediately sent to the user and nearby police station, Therefore one gets maximum security to their ATM card by monitoring it continuously.

## I. INTRODUCTION

In today's technically advanced and developed world, autonomous systems are improvement rapid popularity in world. As the social computerization, automation and developed technics has been increased and the ATM and credit card has been installed and spread out to simplify the financial activity, the banking activity has been simplified so more, however the crime related with financial organization has been increased over numbers in the world in proportion to the ratio of spread out of automation, devices and technologies. Now, a day theft from robbery increases gradually. ATM related crime cases are increases. For stop this situation were

put GSM technology in ATM system. We are only change the software by using GSM technology. By using GSM, we provide double security in the ATM banking. So, same amount of robbery can be control.

## II. LITERATURE REVIEW

The existing predictable ration system has the basic issues of renewing the ration card every year by the employees to the malpractices done by the ration store dealers like diverting food grains to open market to make profit. To tackle this problems K. Balakarathik proposed the "Cloud-Based Ration Card System using RFID and GSM Technology" [1], presents an efficient method for the user to buy the products in the ration shop by just irregular the card at the RFID reader. The user authentication is done by sending a random password text to the user mobile which has to be entered in a keypad. The purchase is validated by the employee only after the details are entered in a windows application which stores the user's personal and purchase information. The current PDS involves corruption and illegal smuggling of goods because of manual work. A.N. Madur et.al. Developed the "Automation in Rationing System using Arm 7" [2], S.Valarmathy et.al. Proposed the "Automatic Ration Material Distributions Based on GSM and RFID Published in A R DIGITECH A R DIGITECH International Journal Of Engineering, Education And Technology (ARDIJEET) www.ardigitech.in ISSN 2320-883X, VOLUME 3, ISSUE 2, 01/04/2015 3 Technology" [4]. Here each customer is provided with RFID cards. In this system, first user is authenticated, and then system shows the balance of person. User have to enter the amount of Kg he wants to withdraw. If the user will have sufficient balance to withdraw the current amount, system will open the

valve. Through valve grain will come and it will get weighted by weight sensor. Once the count reached the entered amount controller automatically shut down the valve and updates the account of the customer.

Proposed the “Automatic Rationing System Using Embedded System Technology” [5], in this the ration distribution system is automated by using PLC. This automated ration system replaces the conventional ration card system by smart card. The proposed ration shop system is connected to the government database via GSM modules, which further sends the up-to-date information to the government and the consumer. So we suggested the “e- Ration Shop: An Automation Tool for Fair Price Shop under the Public Distribution System” [6], this paper discusses strategy adapted in using ICT to control diversion and leakage in the delivery device and its successful application in computerization of food grain supply chain.

### III. METHODOLOGY

#### Components Used

1. Power Supply
2. RFID
3. Arduino NANO - 2
4. BUZZER
5. GSM
6. Liquid Crystall Display (LCD)

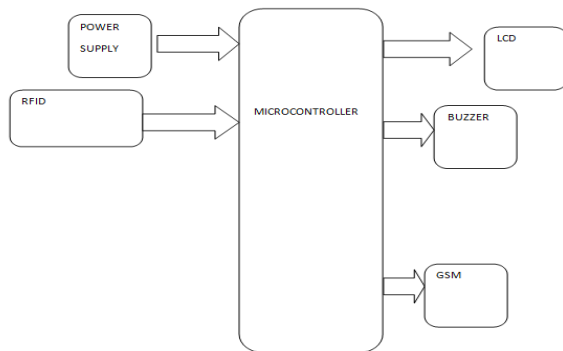

Fig 1. Block diagram of 4G GSM Based Smart Information System using lost ATM Cards.

#### POWER SUPPLY:

The input to the circuit is applied from the regulated power supply. The a.c. input i.e., 230V from the mains supply is step down by the transformer to 12V and is fed to an rectifier then Filtered.

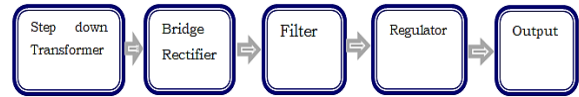

Fig 2. Power supply block diagram

#### RFID:

It is a method of identifying unique items using radio waves. Typical RFID systems are made up of 2 major components: readers and tags. The reader, sometimes called the interrogator, sends and receives RF data to and from the tag via antennas. A reader may have multiple antennas that are responsible for sending and receiving the radio waves.



Fig 3. RFID Tags

#### ARDUINO:

Arduino is an open source platform based on Hardware and Software. Arduino Boards are able to read inputs. Arduino has been used in thousands of different projects and applications. The Arduino Software is easy-to-use for beginners, yet flexible enough for advanced users. It runs on Mac, Windows and Linux.

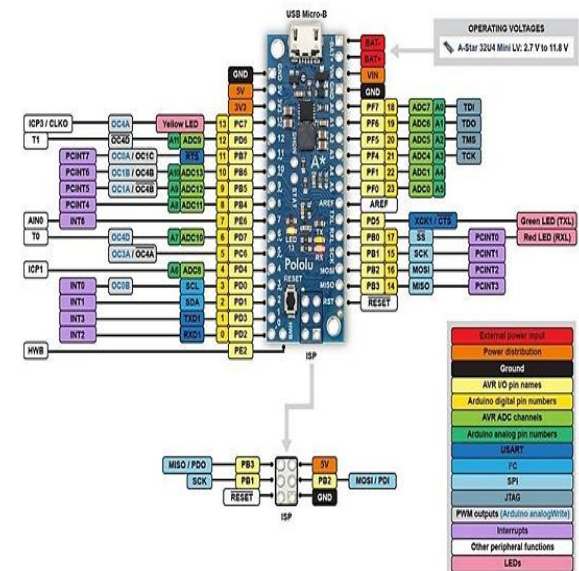

Fig 4. Arduino Nano pin configuration

#### BUZZER:

Active buzzer 5V Rated power can be directly connected to a continuous sound, this section

dedicated sensor expansion module and the board in combination, can complete a simple circuit design, to "plug and play."



Fig 5. Buzzer

**GSM:**

A GSM modem is a wireless modem that works with a GSM wireless network. A wireless modem behaves like a dial-up modem. The main difference between them is that a dial-up modem sends and receives data through a fixed telephone line while a wireless modem sends and receives data through radio waves.



Fig 6. 4G GSM Module

**LCD:**

The liquid crystal display screen works on the principle of blocking light rather than emitting light. LCDs require a backlight as they do not emit light them

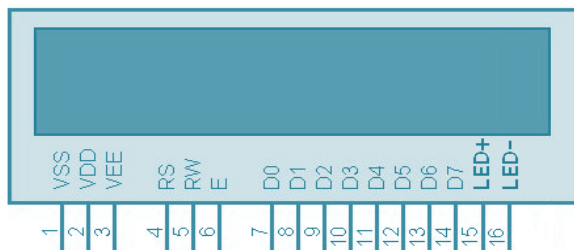

Fig 7. Pin Diagram of LCD

**IV. WORKING**

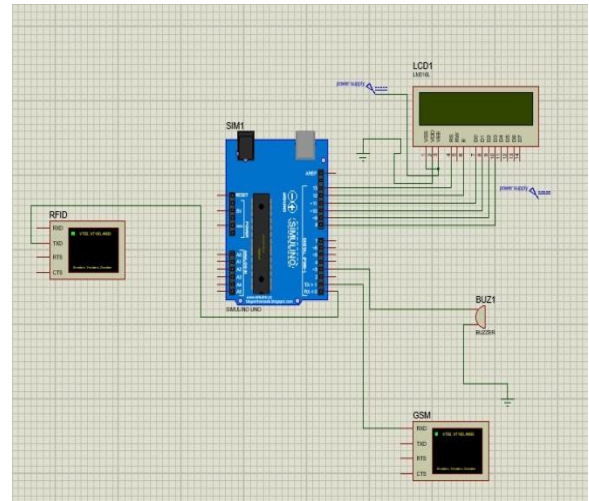
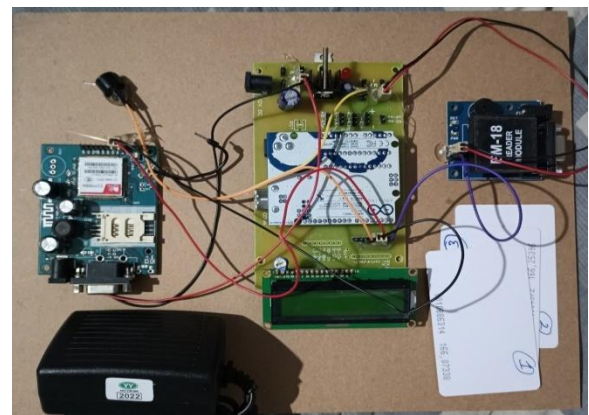

Fig 7. Schematic Diagram of 4G GSM Based Smart Information System using Lost Atm cards

**V. RESULT**



**VI. .ADVANTAGES**

1. More secure for transaction
2. Instantaneous action by using GSM technology
3. Easy to use GSM relates transaction techniques
4. Direct mobile communication system involves

**VII. APPLICATIONS**

1. ATM
2. LOCKER SYSTEMS

**VIII. CONCLUSION**

This whole implementation ensures us a secured and authenticated transaction through GSM technique with lowest cost and minimum maintenance.

Mankind will utilize new and secured type of money transactions. The only thing is that initial cost of GSM module of the entire system is the required one-time investment. Account holder will utilize ATM card by entering password through his predefined mobile number for bank. The value-added service that this system provides increases the credibility of the financial institutions, the banks improves the convenience to its customer. Hence as the world progresses through the inevitable and an indomitable quest for knowledge, the aspect of security bound systems is bound to concede with the growing innovations and obviously more vulnerabilities. Hence our application might well solve the aspect of transaction security to a precise and great extent.

#### REFERENCE

- [1] International Journal of Engineering Research & Technology (IJERT) Vol. 2 Issue 3, March - 2013 ISSN: 2278-0181 ATM Systems Authentication Based on Fingerprint Using ARM Cortex-M3 by Mr. John Mashurano<sup>1</sup>, M.E Signal and Information Processing. And Mr. Wang liqiang<sup>2</sup>, Associate Professor, Optics Lab.
- [2] M. Dinesh Kumar, M.S.Geethanjali, R.Karthika, M.Nagaraj, N.Vijayanandam, "Protected Cash Withdrawal in ATM Using Mobile Phone", International Journal Of Engineering And Computer Science, Vol.2, pp.1346-1350, 2013.
- [3] R. Rasu, P.Krishna Kumar, M.Chandraman,, Security for ATM Terminal Using Various Recognition Systems" International Journal of Engineering and Innovative Technology, 4th October 2012.
- [4] Binachi.A, Oakley.I and Kwon.D.S, "using mobile device screens for authentication", in proceedings of the 23rd Australian computer human interaction conference, o zchi'11, pp. 50-53,2011.
- [5] Agarwal, C. C., Wolf, J. L., and Yu, P. S., "Caching on the World Wide Web", IEEE Transactions on Knowledge and Data Engineering, Vol.11, pp.94-107, 2009.