

ANN Based Power Quality Improvement Using Dual Topology of UPQC under Non-Linear Loads

E.Chinna Sunkaiah¹, L.Sasidhar Reddy², G.Rama Sai³, G.Mounika⁴, K.Reshma⁵, C.Sagar Kumar Reddy⁶, K.Sampada⁷

¹Assistant Professor, Department of EEE, Gates Institute of Technology: Gooty, A.P, India
^{2,3,4,5,6,7} UG Student, Department of EEE, Gates Institute of Technology: Gooty, A.P, India

Abstract: In the distribution system grid the operation of power quality conditioner has increased during the past few years due to the constant increase of nonlinear loads linked to the electrical network. It is feasible to ensure a modulated voltage for the loads, balanced and with low harmonic distortion and at the same time leaving undistorted current from the utility grid by employing a Dual topology of unified power quality conditioner. The Dual UPQC incorporates of two active filters the shunt active filter and the series active filter. The Dual UPQC (iUPQC) is combination of two active filters, a series active filter and a shunt active filter (parallel active filter), used to terminate harmonics and unbalances. Divergent from a conventional UPQC, the iUPQC has the series filter managed as a sinusoidal current source and the shunt filter constrained as a sinusoidal voltage source. Thus, the pulse width modulation controls of the iUPQC deal with a well known frequency spectrum, since it is supervised employing voltage and current sinusoidal references, divergent from the conventional UPQC that is Controlled employing non sinusoidal references. This can establish Dual UPQC (iUPQC) with ANN controller for power quality improvement by considering sudden load changes.

Keywords –ANN, Active power filters (APF), Dual Unified Power Quality Conditioner (iUPQC), active and reactive power control, unified power quality conditioner (UPQC).

I. INTRODUCTION

Due to use of nonlinear power electronics loads, like static rectifiers, variable speed drives, dc/ac converter, has produce many electric power quality problems such as high current harmonics, poor power factor and more neutral current, etc. “Power Quality is a set of limits of electrical properties that permits Electrical system to function in their intended manner without loss of performance or life”. Trouble caused by power quality can have an adverse economic impact on utilities

Fig.1 Power quality difficulty in a typical industrial installation

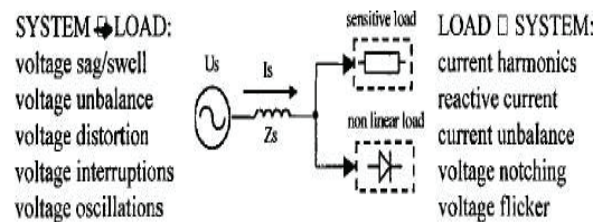

Power flow is controlled by the control actions employing FACTS devices, which incorporate (i) Static VAR Compensators, (ii) Thyristor Controlled Series Capacitors, (iii) Static Series Synchronous Compensators, (iv) Static Compensators, (v) Unified Power Flow controllers (vi) Unified Power Quality Conditioner, etc. out of these facts controller here for power quality enhancement we examine Dual topology of Unified Power Quality Conditioner. By the use of Dual topology of unified power quality conditioners, these power quality problems can be resolved. The Dual unified power quality conditioner, which is fusion of the shunt and series active filters used to remove harmonics and unbalances.

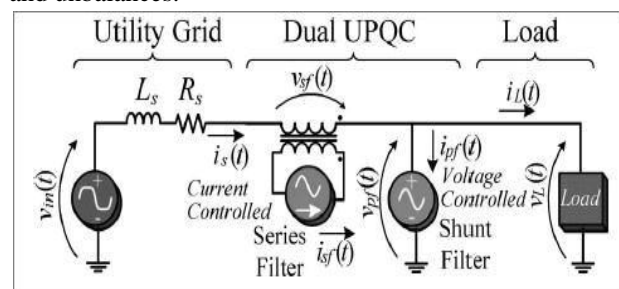

Fig.2 Dual UPQC (iUPQC)

In iUPQC, the SAF act as a current source, which deliver to a sinusoidal input current synchronized with the network voltage. The PAF works such as voltage source dignifying sinusoidal load voltage synchronized with the network voltage.

Therefore, the pulse width modulation (PWM) controls of the iUPQC deal with a well-known frequency spectrum, since it is controlled by using voltage and current sinusoidal references for both active filters.

The SAF acts as high impedance for the current harmonics and indirectly compensates the harmonics, Unbalances, and interference of the network voltage since the connection transformer voltages is equal to the distinction between the grid voltage and the load voltage. Similarly, the PAF indirectly compensate the unbalances, displacement, and harmonics of the network current, provision of a low-impedance path for the harmonic load current. By employing Dual UPQC we can separate the complex harmonic extraction of the grid voltage.

II. OBJECTIVES

The main purpose of the Dual UPQC is

- 1) Source current linear concerning with nonlinear load
- 2) Constant load voltage
- 3) Eliminates harmonic load voltage

III. CONTROL SCHEMES

In the present control scheme, the power computation and harmonic extraction are not needed since the harmonics, unbalances, disturbances, displacement should be recompensed. The SAF has a current loop in order to certify a sinusoidal grid current synchronized with the network voltage. The PAF has a voltage loop in order to verify a balanced modulated load voltage with low harmonic deformation. These control loops are self-determining from each other since they act independently in each active filter

A. SAF Control: The SAF control strategy contains of three identical grid current loops and two voltage loops. The current loops are liable for tracking the reference to each grid input phase in order to control the grid currents. One voltage loop is responsible for regulating the total dc link voltage, and the other is liable for avoiding the unbalances between the dc link capacitors.

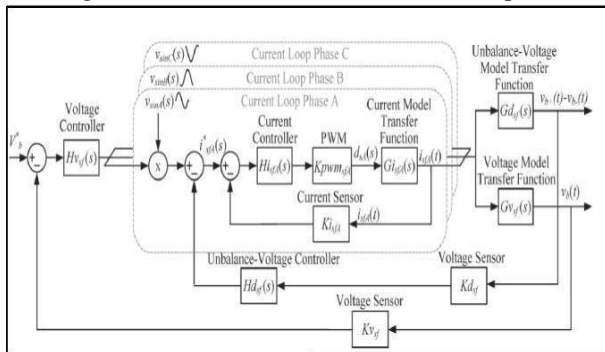

Fig.3 Control of SAF controller

When the load increases, overcoming the input grid current, the dc link provides momentarily the active power utilization, resulting in diminish of its voltage. This voltage controller proceed to raise the grid current

reference, when the load diminish, the voltage controller reduces the grid current reference to modulate the dc link voltage.

B.PAF Control

Figure 4 shows the control block diagram of the shunt active filter controller. The PAF control scheme is form by three identical load voltage feedback loops; the voltage loops are liable for tracking the instantaneous voltage reference for each load output phase in order to control the load voltages separately.

The dynamic model is achieved by the circuit Aanalysis using average values related to the switching period. Through small signal scrutiny and by employing Laplace.

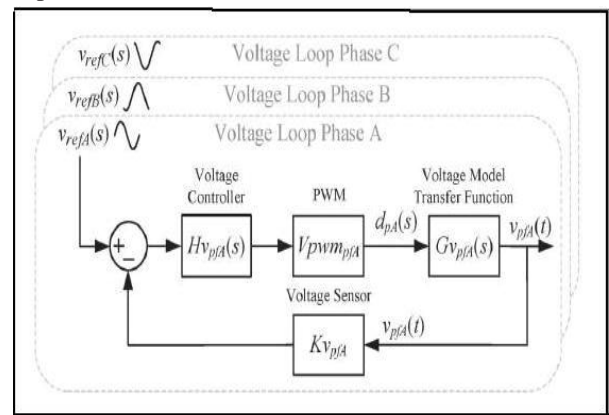

Fig.4 Control block diagram of the PAF voltage loop

IV.MODELING OF DUAL UPQC

Simulation was built in several steps from grid source to load, Dual UPQC operation at various loads is as shown in fig 5. Power Circuit of iUPQC is consist of two four wire three-phase converter connected b a c k-back and their respective output filters as shown in figure 6.

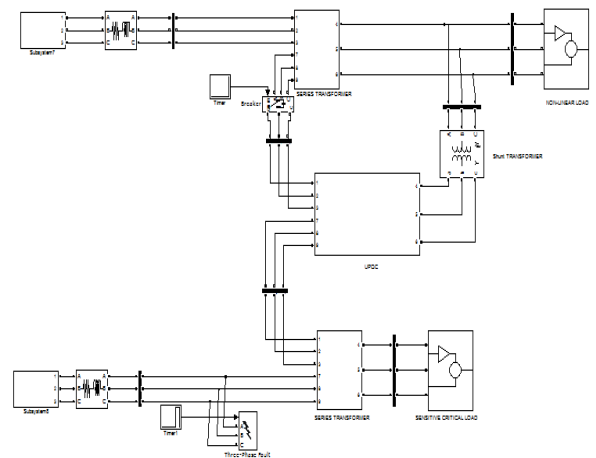

Fig5.Simulink Design of IUPQC

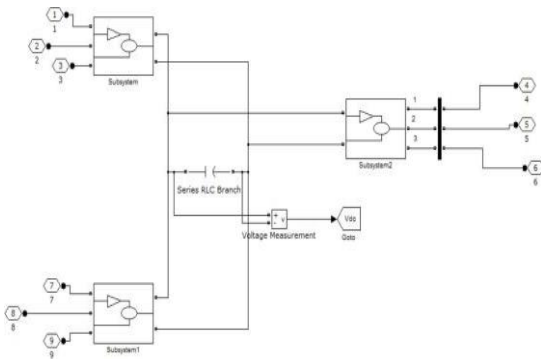

Fig6.Power Circuit of iUPQC

V.SIMULATION RESULTS WITH ANN CONTROLLER

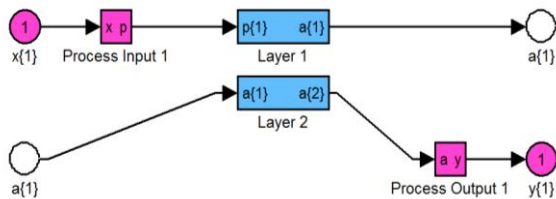

Fig7.Simulation model of ANN

The results are taken out by considering sudden changes in load conditions. Such as low voltage, rapid load step.

CASE A: Consider a three phase source current. Out of those three phases, phase A has dip after two cycles. But by Dual UPQC compensation modulated load voltage is taken out. Figure 8 shows the load voltage and source current by considering dip in source current and modulated load voltage.

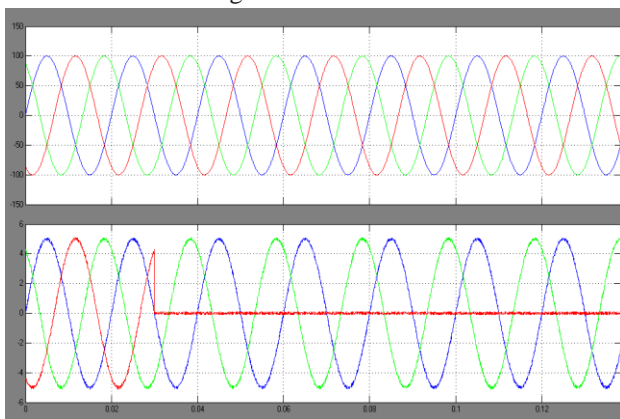

Fig8.Load voltage and source current dip

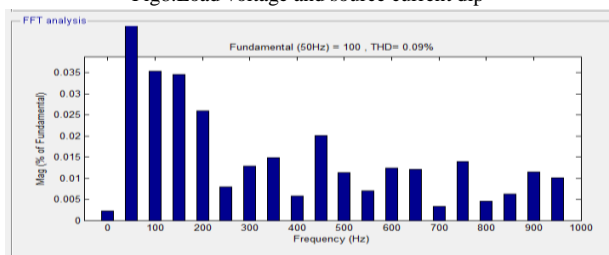

Fig9.TH D analysis

CASE B: Consider a three phase load current. There is immediate increase in a magnitude of current. But by Dual UPQC compensation modulated load voltage without change in magnitude is taken out. Figure10 shows the load voltage and load current by considering load current step from 50% to 100%

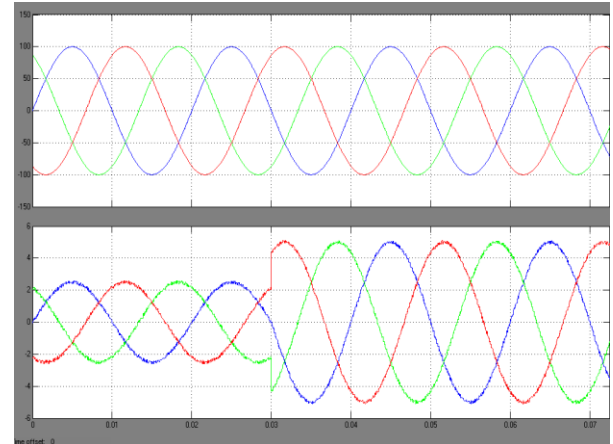

Fig10.Load voltage and load current step

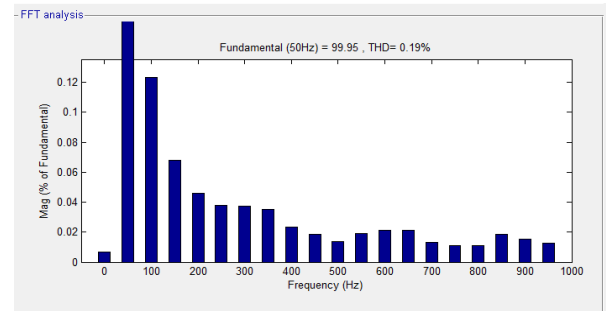

Fig11.TH D analysis

CASE C: Consider a three load current. There is a rapid decrease in magnitude of current. But by Dual UPQC compensation modulated load voltage without change in magnitude is separated. Figure 12 shows the load voltage and load current by considering load current steps from 100% to 50%.

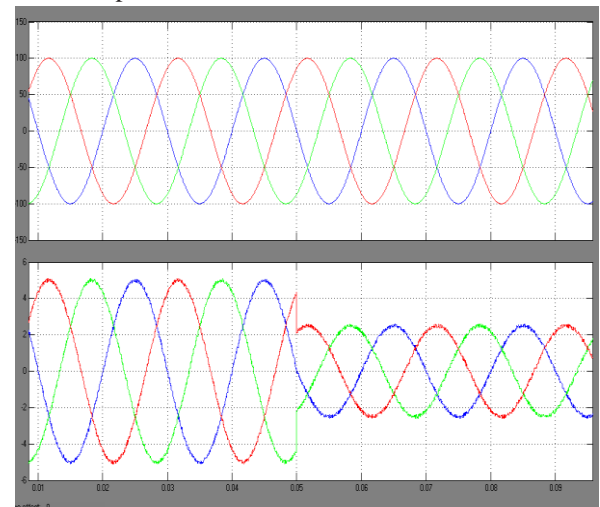

Fig12.Load voltage and load current step

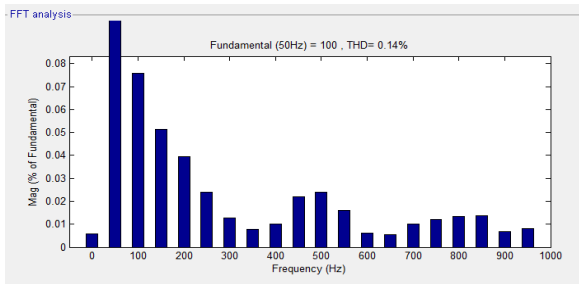

Fig13. THD analysis

IV. CONCLUSION

The results obtained with the IUPQC able to compensate the non linear load Currents and also certain the sinusoidal voltage for the load in all three phases. The control also had a great operation during the load steps and voltage disturbances at the source. The main advantages of this initiate control in relation to the other proposed schemes of ANN control were the utilization of sinusoidal references for both series and shunt active filter controls without the requirement of complicated calculations or coordinate transformations. By the use of Dual UPQC, it can confirm that current source linear with respect to nonlinear load, Constant load voltage; this model Eliminates harmonic load voltage.

REFERENCE

- [1] Vinod Khadkikar, "A New Control Philosophy for a UPQC to Co-ordinate Load-Reactive Power Demand between Shunt & Series Inverter" IEEE Transaction on Power Delivery, Vol.23, No.4, October2008.
- [2] Mr. Suhas M Shembekar, "A Comparative Analysis of UPQC for Power Quality Improvement" IJIRAE ISSN: 2349-2163, Issue 4, Vol 2, April 2015.
- [3] AhmetTeke, "A Novel Reference Signal Generation Method for Power Quality Improvement of UPQC" IEEE Transaction ON Power delivery, Vol.26, No.2, April 2010.
- [4] Santhanayaki.T "Identification of Sags and Swells using PIC Microcontroller" IJSRET, vol.1 Issue 12, pp. 011-016 March 2013.
- [5] Sung-Hunko, "Application of Voltage & CurrentControlled Voltage Source Inverter for Distributed Generation System" IEEE Transaction n Energy Conversion, Vol.21, No.3, September 2006.
- [6] S.Mangayarkarasi, "Enhancing Electric PowerQuality Using Dual Unified Power Quality Conditioner" IJETCSE ISSN:0976-1353 Volume 12 Issue 3-January 2015.
- [7] Amit Kumar Jindal, "Interline Unified Power Quality Conditioner," IEEE Transaction on Power Delivery, Vol.22, No.1, January 2007.
- [8] Dong Myung Lee, "New Control Scheme for a UPQC-Q with Minimum Active Power Injection" IEEE Transaction on Power Delivery, Vol.25, No.2, April 2010.
- [9] Morris Brenna, "A New Proposal for Power Quality & Custom Power Improvement: OPEN UPQC" IEEE Transaction on Power Delivery, Vol.24, No.4, OCTOBER 2009.
- [10] Dusan Graovac, "Power Quality Problems Compensation with Universal Power Quality Conditioning System" IEEE Transaction on Power Delivery, Vol.22, No.2, April 2007.
- [11] B.Han, "New Configuration of UPQC for Medium-Voltage Application" IEEE Transaction on Power Delivery, Vol.21, NO.3, July 2006.
- [12] Hideaki Fujita and Hirofumi Akagi, "The Unified Power Quality Conditioner: The Integration of Series- and Shunt- Active Filters", IEEE Transactions on Power Electronics, VOL. 13, NO. 2, MARCH 1998.
- [13] Mauricio Aredes, "An Universal Active Power Line Conditioner" IEEE Transaction on Power Delivery, Vol.13, No.2, April 1998.
- [14] Vinod Khadkikar, "Enhancing Electric Power Quality Using UPQC: A Comprehensive Overview", IEEE Transactions on Power Electronics, Vol. 27, No. 5, MAY 2012.
- [15] Raphael J. Millnitz "A Simplified Control Technique For A Dual Unified Power Quality Conditioner" IEEE Transactions on Industrial Electronics, Vol.61, No.11, November 2014.