

PV- Vortex Blade-less Wind Hybrid System Based Cuckoo Search Maximum Power Point Tracking Algorithm

Mr. B.Samuel Naik¹, Dr.B.V Shanker Ram², Dr.M.Rajendar Reddy³, Dr.M.Sudhakaran⁴

^{1,2,3,4}*Department of Electrical and Electronics Engineering (Power Engineering and Energy System) Mahaveer Institute of Science and Technology, Affiliated to JNTU Hyderabad, Vyasapuri, Bandlaguda, Keshavgeri, Hyderabad*

Abstract - Finding a PV-Vortex Blade-less Wind hybrid system with maximum power point using Cuckoo search MPPT is the major objective of this article Blade-less freestanding hybrid systems employing wind and solar energy may now be built at a fraction of the cost. It is difficult to keep up with quickly changing environmental circumstances using typical MPPT algorithms (incremental conductance, P and O, and particle swarms). The Cuckoo Search Algorithm (CSA), an evolutionary algorithmic approach, is used to find the best quantity of electricity. For both WIND and PV, the DC-DC step-up boost converters are being employed using the CS artificial intelligence technique. After the maximum power point tracking technique is proposed to the DC link or DC loads, the DC/DC converters raise the voltage of the two sources. Matlab Simulink is used to develop and verify the outcomes of the Blade-less hybrid system.

1.INTRODUCTION

The amount of electricity that is being used is rising at a faster rate than the amount of power that is available. Because of these two problems, one approach is to use renewable energy sources that are infinite and non-polluting to generate electricity. Many benefits may be which may be found in renewable energy resources such as wind and solar electricity The horizontal axis wind turbine, the vertical axis wind turbine, and the Darius wind turbine are among the many wind turbines that have been produced throughout the years. However, these turbines have a number of downsides, including large initial investment prices, noise and bird deaths, as well as a lack of constant wind supply. It is possible to generate power using solar, but the problem is that solar is not accessible at night and does not produce electricity. As a result, employing a single renewable energy source may not be sufficient to fulfil

the system's demands, and therefore a hybrid system is created by mixing different sources [2, 3]. Hybrid power production systems [4-6] employ more than one source of energy to generate electricity and may be used to operate the load in the event that one is unavailable. Self-contained Although the typical wind turbine has drawbacks including higher wind speed requirements, high investment costs, the murder of birds, and excessive noise, the solar wind hybrid power producing system makes use of both the sun and the wind as its sources of energy. The Blade-less wind turbine's notion of vortex-induced vibrations is superior to the conventional horizontal-axis wind turbine design in many ways [4]. The oscillatory movements induced by wind moving through a building are known as vortex vibrations. In order to convert these oscillations into electrical energy, devices such as piezoelectric cells, crank and shaft mechanism, linear alternator, and transducer [7] may be employed. However, they provide small energy and need a lot of maintenance. A high gain step-up DC-DC converter might be used instead of a regular boost converter if the quantity of energy that can be produced is a concern. To reduce filter requirements and output energy total harmonic distortion, a three-level inverter may be used instead of a normal two-level inverter.

2.RENEWABLE ENERGY SOURCES

2.1 Introduction:

There has been a continuous growth in the need for renewable energy sources due to the shortage of fossil fuels and the effect of global warming. Due to advances in power electronics, solar and wind energy

have become some of the most popular and sought-after renewable energy sources. Because of its low maintenance requirements and lack of environmental impact, photovoltaic are now used in a wide variety of products. Over the last 20 years, solar-electric-energy consumption has increased at a rate of 20 percent to 25 percent each year, mostly owing to lower costs and lower prices.

This decline has been driven by the following factors:

- 1) An increasing efficiency of solar cells
- 2) Manufacturing technology improvements and
- 3) Economies of scale.

Power from PV modules is converted to ac power and delivered into the grid via an inverter, which is the system's "heart." Increasing the inverter's output waveform leads to a smaller filter and lower levels of electromagnetic interference since it decreases the inverter's harmonic content.

Fossil fuels' exhaustible, rising prices and global pollution have fueled an enormous interest in alternative energy options. When it comes to supplying our energy needs, wind and solar power are the best options. This renewable source of energy is capable of generating enormous quantities of electricity, but its availability cannot be forecast. Although solar electricity is accessible 24 hours a day, solar irradiance levels vary according to the sun's strength and shadows, which are influenced by several factors.

There is a general consensus that solar and wind power complement each other. As a result, a hybrid photovoltaic and wind energy system is more reliable than any of these systems running alone. Because hybrid systems are more dependable than their standalone counterparts, battery storage requirements may be reduced.

2.3 Photo Voltaic Systems:

Photovoltaic systems are made up of a variety of linked parts that may be used to power anything from a tiny item to the whole grid. Figure 2.1 shows how photovoltaic systems may be divided. The stand-alone and grid-connected systems are the two primary generic classes shown in the picture. Solar energy production is matched to demand in stand-alone systems, however in grid-tied systems, this is not the case. Storage elements are often utilized to accommodate a variety of load patterns, and batteries

are the storage element of choice for the majority of systems today.

Hybrid systems combine a photovoltaic (PV) system with another power source, such as a wind turbine or diesel engine. A solar system's life cycle costs are heavily influenced by the balances of system components. Power conditioning, storage, and mechanical structures are included in the package. They have a significant influence on the PV system's operational expenses, in particular.

2.3.2 PV Module:

In order to generate sufficient voltage and power, several solar cells must be coupled in series or parallel in the majority of applications. To obtain the necessary output voltage, individual cells are often linked in a series string of 36 or 72 cells. Customers often buy modules from manufacturers, which is what they term the whole assembly. As the solar cells are encased in a single or double layer of glass, they provide additional protection from water, dust, and other contaminants.

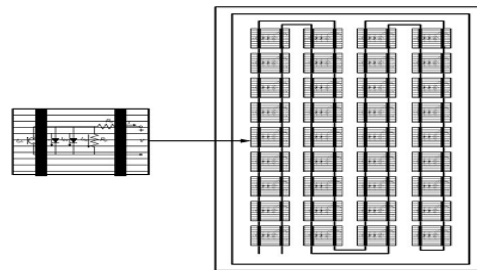

Figure2.3: Structure of a PV module with 36 cells connected in series

A module's cells may be wired in either series or parallel, however most modules use series wiring. An example of a typical series connection of 36 cells may be seen in the figure at right (Fig. 2.3). In a series connection, the voltage at the module terminals equals the total of the voltages of all the cells, hence the current through all the cells is the same. As a result, it is very important that the cells in the series string be properly matched to ensure that all cells are operating at their optimum power levels. It is possible to link a series of modules in parallel and have a voltage equivalent to the voltage of a single cell.

2.5 Vortex Blade-less wind technology

In 1938, an accident occurred on Tacoma's Bridge that inspired the development of the vortex technology for wind energy absorption. [8] The bridge's breaking activity was caused by the vibrating harmonic

movement, which failed the structure's measurement. There would be a significant energy source at that location if the energy produced for correct bridge movement could have been captured and converted to electric energy. This is where David Yaez and David Suriol, two Spanish technology engineers and co-founders of the technology development firm Vortex Blade-less, got their inspiration. Vortex Shedding is a phenomenon of voracity that can be harnessed with Vortex Blade-less technology. What happens when a vortex street is generated by the flow of a gas or air stream and transported downstream by the vortices created by the aerodynamic conditions of a solid body? Vortex Blade-less utilizes an elastic rod to hold a conical cylinder vertically. For low power distribution or self-consumption, the linear alternator system produces energy by the oscillation of the cylinder in wind. [9]

2.5.1 Technical description

In order to keep the outer conical cylinder in place, it is intended to be both robust and able to vibrate. The highest oscillation amplitude is found near the top of the cylinder. Conventional wind turbine blades are made of polymers reinforced with carbon and/or glass fibers. The inner cylindrical rod is fixed to the mast at the top and secured to the ground at the bottom, with the possibility of passing through the mast for up to 30% of its length. Using carbon fibre, which has the best fatigue resistance and a high mechanical quality factor, it can absorb the cylinder's vibratory energy. In order to harness the energy of vortex shedding, the gadget utilizes a vorticity-based aerodynamic phenomenon. A cyclical pattern of vortices is formed when the wind travels past a blunt object. To begin oscillations, the body must first have enough lateral wind forces to be powerful enough. Vortex Induced Vibration is another name for this phenomenon.



Figure 2.9 Vortex Blade - Less Farm



Figure 2.10 Vortex Resonance Phenomena

Aerodynamic instabilities aren't avoided; they're amplified and harnessed by this new technology. Traditional wind turbines are, of course, quite different from a system like this. With a permanent, lightweight, stiff mast constructed of fibreglass, it is tethered to a hollow and flexible carbon fibre rod that is connected to the ground at its bottom end. On the basis of these principles, as well as other scientific phenomena such as Boltzmann's law, finite body aerodynamics, turbulence zones, and so on. Developing computational models that aid in Vortex's development and improvement.

2.5.2 The alternator

AC current is generated by electromagnetic induction from mechanical energy, which the electric machine must convert into electric energy. Electromotive force (a difference in potential that tends to produce an electric current) is the basis for alternator functioning. The induced E.F. is equal to the total of the force fluctuations of each time and each movement in the electric circuit when the magnetic field changes throughout time. This may be stated in terms of numbers:

$$\epsilon = \int E_{ef} T dl = \int (v \times B) dl T - \int \delta B \delta t dS T$$

The equation's first and second parts deal with movement and time-varying variations in the magnetic field, respectively. There are two ways of expressing these two concepts as a change in electromagnetic flux, one for each of them being:

$$\epsilon = - \delta \phi \delta t$$

The Faraday Law may be expressed mathematically using the equation shown above [11]. The alternator system that powers the vortex is constructed of coils and magnets specifically tailored to the vortex's dynamics, with no gears or other moving elements in

the way. Even yet, the generator's technology is proprietary and system-innovative. The answer is based on a unique process known as the theory of rings repulsion and does not need the usage of any gear. Since there are no moving components, the gadget does not need to be maintained or lubricated as it has been discussed before. In any event, early experiments suggest that the electrical conversion yields attained by a standard rotary alternator are between 70 and 85 percent.

The alternator's components

To convert mechanical energy to electrical energy, the alternator has general components. The mechanical energy in this scenario originates from the wind blowing through the stick's structure: An electromagnet gets current from the regulator via the rings on the shaft of the alternator, which is movable. As a result of the magnet's magnetic field, an electric current is generated in the stator coils. The alternator's regulator is in charge of ensuring that its maximum output voltage is always maintained. There is less current for the rotor at a faster RPM due to a larger magnetic field and more voltage being generated by the machine (inductor). The three-phase winding is permanently attached to the stator. A star or a triangle may be formed from this. With three independent winding's and precisely separated slots, the shield's conductors create the winding that forms the stator. The three winding's, or phases of the alternator, may be linked in either a star or a triangle configuration, resulting in a three-phase alternating current at their terminals [12].

2.5.3 Economy description

Vortex's minimal related expenses are one of the technology's primary benefits. At 35 €/MW h (\$900 CZK/MW h), the levelized cost of energy generation (LCOE) for the average onshore plant includes capital expenditures, operations and maintenance, performance and land leasing, insurance and other administrative charges [13]. These minimal capital requirements make it very competitive not just with current and future generations of alternative or renewable energy sources, but also when compared to more traditional options.

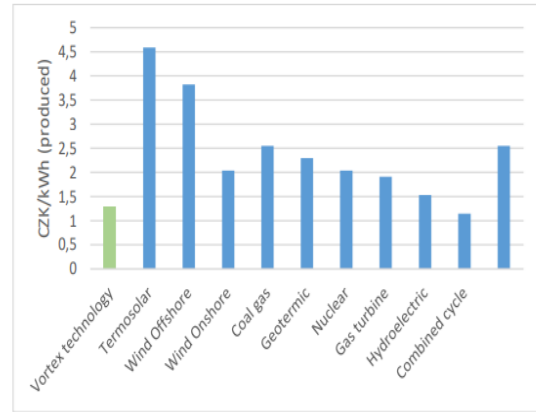
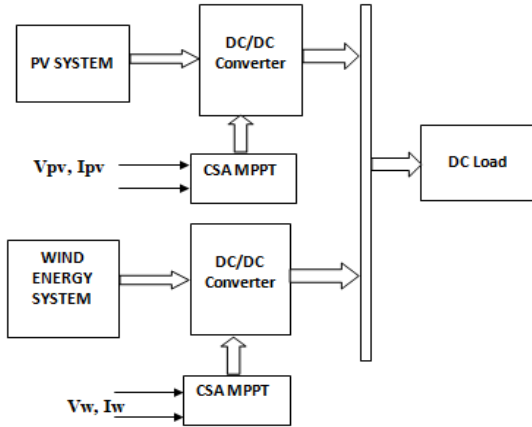

Fig 2.11 Specific cost for producing 1 kWh Source Vortex technology has only been tested on the ground, thus direct comparisons should be made with Wind Onshore sources. Despite the fact that there are other studies going on at the same time where prototypes of Vortex devices may be found in the water, such as in the United States, this project will not be comparing its technology to others found offshore. As a result, according to this citation [14], information about it may be accessed on the internet.

4 MODELLIONG OF CASE STUDY

4.1 PROPOSED SYSTEM

The Blade-less hybrid system that has been proposed generates vibrations as a result of vortices, as seen in the image below (3.1). For an integrated system, the Blade-less wind turbine uses a tapered cylindrical mast made of glass or carbon fibre, with a rod pivoted into the mast to support it. As wind passes over the mast, vortex vibrations produce an oscillating force around it, which causes the mast to dislocate. As a result, the mast's oscillation may be increased by using a spring that is attached to the turbine's bottom. An elector-acoustic transducer and diode-bridal rectifier convert these vibrations into electrical energy and DC power. A Blade-less hybrid system combines a solar panel with a Blade-less turbine. Cuckoo Search MPPT helps to maintain a constant DC output voltage and maximum output power by controlling the gate pulses of the DC/DC converter (CS-MPPT). [5] CS-MPPT, which links a solar photovoltaic cell to a boost converter, is used for maximum power extraction (MPPT).



4.1 Block diagram of hybrid system.

4.1.2 PV Cell Modeling:

A photovoltaic (PV) cell's equivalent circuit is depicted in Figure 4.2. A current source and a diode in parallel are used to simulate a perfect solar cell. A series and shunt resistance are added to the device illustrated in the image since no solar cell is perfect. There is a very tiny series resistance called R_s . R_p is the extraordinarily high equivalent shunt resistance.

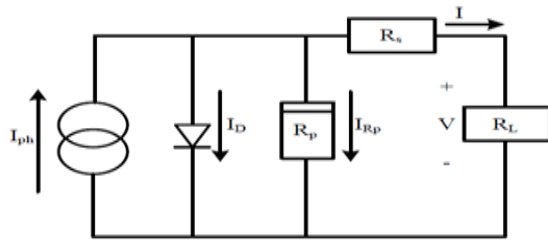

4.2 Equivalent Circuit of PV cell

Applying Kirchhoff's current law to the junction where I_{ph} , diode, R_p and R_s meet.

$$I_{ph} = I_d + I_{R_p} + I$$

We get the following equation for the PV cell current

$$I = I_{ph} - (I_d + I_{R_p})$$

$$I = I_{ph} - (I_0 [e^{(v+IR_s)/V_T} - 1] + (v+IR_s)/R_p)$$

There is an insolation current, a cell current, a reverse saturation current, a voltage, a series resistance, a parallel resistance, and a thermal voltage in this equation. V_T is the thermal voltage.

4.2 BLADELESS WES MODELLING

Bladeless wind turbine is basically a system consisting of mass m and spring having stiffness of S_{stiff} can be shown with mass spring system which is shown in below Figure 3.

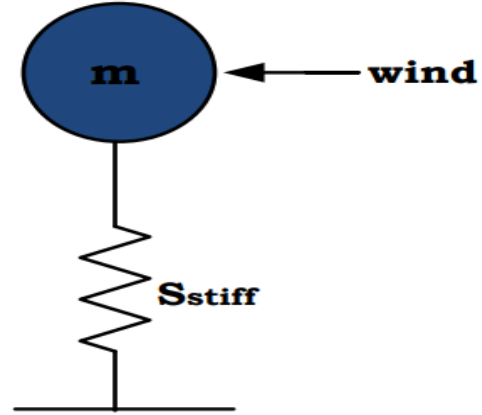

4.3 Mass Spring System

The following are the designing equations [9, 10] involved for the spring mass system. A tapered cylindrical structured mast made of fiber whose mass is given as

$$m = \frac{\pi}{3} \rho L (D^2 / 4) \tag{4.4}$$

where L is length of the mast, ρ is density of air, D is the diameter of mast. The flow of wind over the mast induces vortex vibrations which can be characterized by the Reynolds number and strouhal number given as

$$R_n = \frac{U_w D}{\mu} \tag{4.5}$$

where U_w is velocity of wind, μ is kinematic viscosity. For the Reynolds number vs strouhal number data strouhal number, $Str_n = 0.2$ for considered wind speed. These vortex vibrations can be determined with a frequency called strouhal frequency f_{str} [9] can be given as

$$f_{str} = \frac{Str_n U_w}{D} \tag{4.6}$$

A spring used for increasing oscillations of the mast with spring stiffness [9] given as

$$S_{stiff} = m \omega_{nat}^2 \tag{4.7}$$

where ω_{nat} is natural frequency of the mass spring system. The resultant of the vortex vibrations produces alternating lift forces F_{lift} [9] can be given as

$$F_{lift} = \frac{1}{2} \rho U_w^2 A_m L_{coeff} \tag{4.8}$$

where A_m is area of the mast, L_{coeff} is coefficient of lift force. The resulting displacement Z of the mast [9] can be given as

$$\ddot{z} = \frac{F_{lift}}{m} - \frac{S_{stiff} z}{m} \tag{4.9}$$

4.3 Boost Converter:

If you take the Input Voltage and divide it by the Duty Ratio, you get $V_o = V_d / (1-D)$. The Boost Converter raises the output voltage of the solar panel. The Boost Converter Circuit is shown in the following diagram.

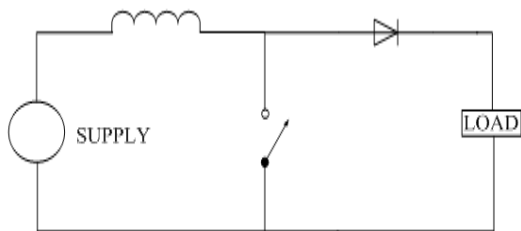

4.4 Boost Converter Circuit

4.4 CUCKOO SEARCH METHOD

Violent parasitism (the laying of eggs in other birds' nests) is followed by cuckoo that keep eggs. CS is governed by three fundamental rules: A single egg is put in a randomly selected nest for each lone cuckoo.

(a) The following generation shall be conveyed to the finest nest with remarkable eggs. Pa cin [0, 1] in preset egg ghost birds provides the predefined nest statistics and probability. Answering particles and the bird of the cuckoo is the solution to this approach are the cuckoo birds. Because of the Lévy distribution, it is feasible to locate local peaks while reducing the time it takes to locate global peaks [15]. Fig. 3.5 shows the CS[16] flowchart.

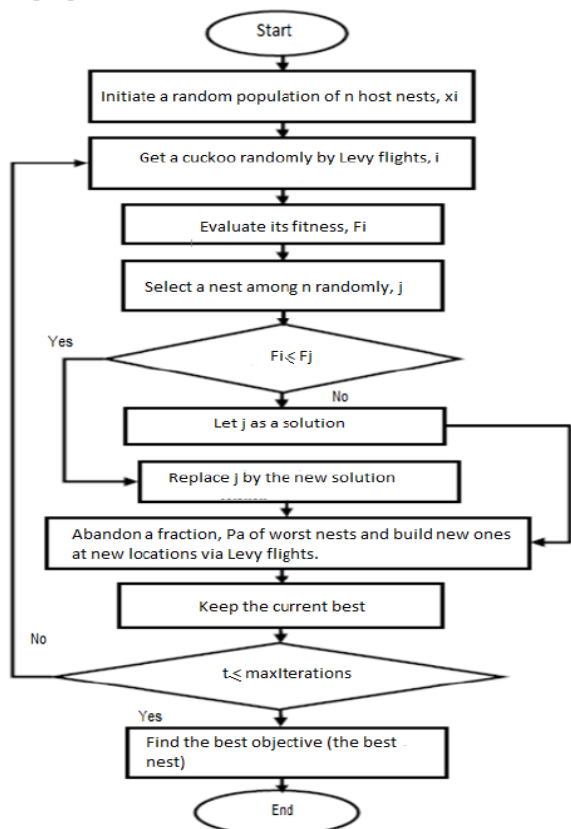

Fig. 4.5 shows the CS[16] flowchart.

5.SIMULATION OUTPUTS

6.1 PV WITH CS MPPT

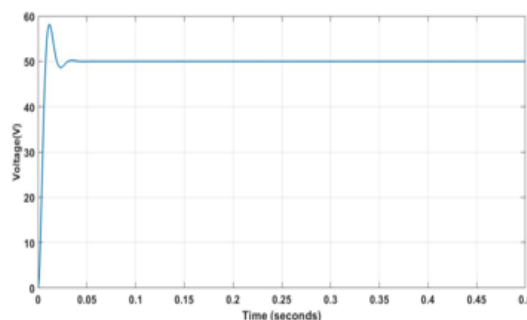

Fig. 6.2 PV voltage

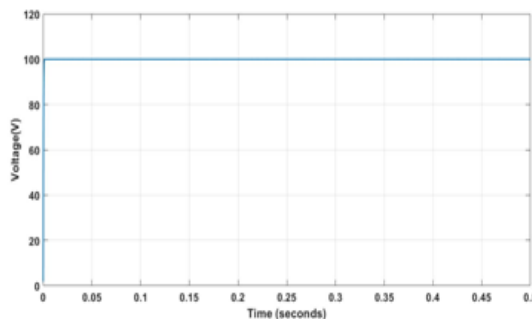

Fig.6.3 PV boost voltage

STEP CHANGE IN IRRADIANCE

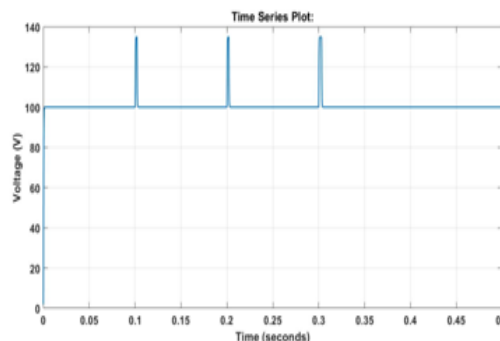

Fig. 6.5 PV boost voltage

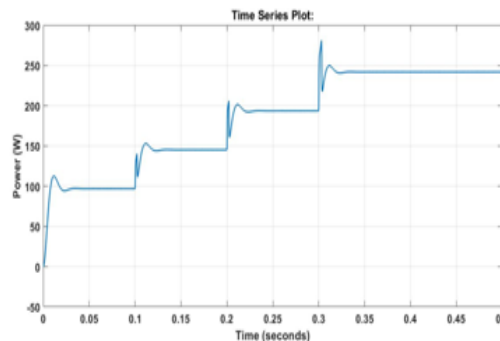

Fig. 6.6 PV power

6.2.BLADELESS WIND WITH CS MPPT

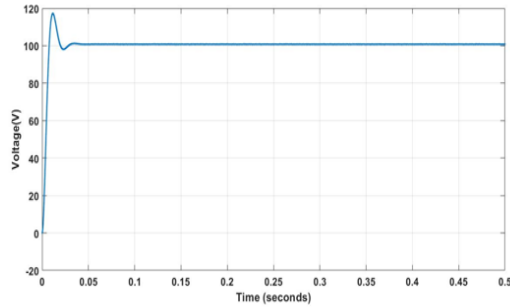

Fig.6.7 WIND boost voltage

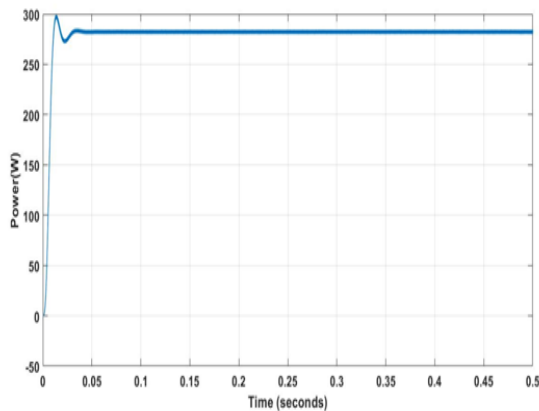

Fig.6.8 WIND power

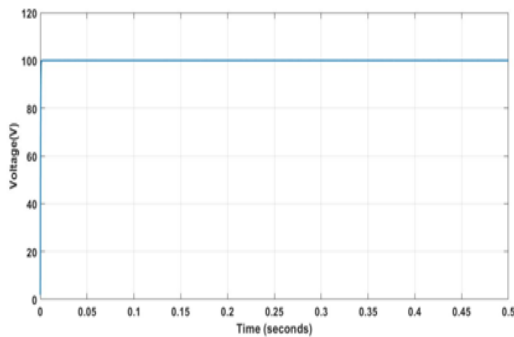

Fig.6.9 Load Voltage

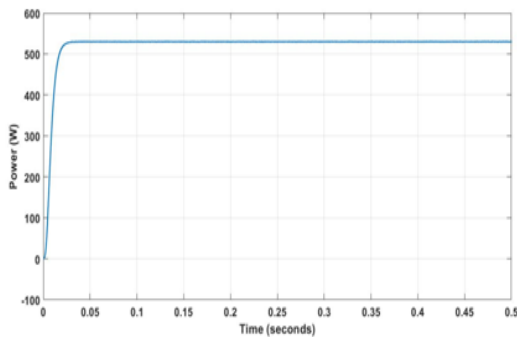

Fig.6.10 Load Power

6.CONCLUSION

For distant power applications, a stand-alone Photovoltaic-Blade-less Wind hybrid power system is built and simulated in this research. A dialogue box similar to those found in SIMULINK block libraries was used in the model's design, which was implemented using the MATLAB/SIMULINK software package. The quantity of electricity a PV system can produce is determined by the amount of solar radiation it can generate. In order to compensate for the PV system's inadequacies, it was chosen to link the PV module to the Blade-less wind turbine system. The dynamic behaviour of the proposed model was examined using a PV system with a Blade-less wind energy conversion device. The total power of the two sources (PVA and WF with Cuckoo MPPT) is around 525W in the proposed system. Both systems use a 100V DC link voltage.

REFERENCE

- [1] Praveen, S., Shimi, S.L., Lini, M. (2016). Design and implementation of MPPT technique applied to solar wind hybrid system. *International Journal of Advanced Research in Computer and Communication Engineering*, 5(7): 604-609. <http://doi.org/10.17148/IJARCCCE.2016.57120>
- [2] Gadad, S.A. (2016). Mathematical modeling of hybrid wind and photovoltaic energy system using Matlab/Simulink. *International Journal for Innovative Research in Science & Technology*, 3(3): 85-92.
- [3] Nnadi, D.B.N., Odeh, C.I., Omeje, C. (2014). Use of hybrid solar-wind energy generation for remote area electrification in South-Eastern Nigeria. *Journal of Energy in Southern Africa*, 25(2): 61-69. <http://doi.org/10.17159/2413-3051/2014/v25i2a2670>
- [4] Bogaraj, T., Kanakaraj, J., Chelladurai, J. (2015). Modeling and simulation of stand-alone hybrid power system with fuzzy MPPT for remote load application. *Archives of Electrical Engineering*, 64(2): 487-504. <https://doi.org/10.2478/aee-2015-0037>
- [5] Anjali, R., Mohammad, I. (2015). Implementation of a Wind/PV hybrid system using MATLAB/Simulink. *International Journal of Advanced Research in Electrical, Electronics and*

- Instrumentation Engineering, 4(7): 5941-5948. <http://doi.org/10.15662/ijareeie.2015.0407019>
- [6] Manfrida, G., Rinchi, M., Soldi, G. (2016). Dynamic model of a vortex-induced energy converter. In *Journal of Energy Resources Technology*, 138(6). <http://doi.org/10.1115/1.4033587>
- [7] Baidwan, K.I.S., Kumar, C.R.S. (2015). Design of linear variable differential transformer (LVDT) based displacement sensor with wider linear range characteristics. *International Journal of Science & Technology*, 3(4): 74-79.
- [8] Murugesan, M., Pari, R., Sivakumar, R., Sivaranjani, S. (2016). Different types of multilevel inverter topologies—a technical review. *International Journal of Advanced Engineering Technology*, 7(1): 149-155.
- [9] Mohammed, J.M., Intan, Z., Mat, D. (2014). Active vortex induced vibration controller and neuro identification for marine risers. *Journal of Theoretical and Applied Information Technology*, 70(1): 153-163.
- [10] Zhang, M.M., Cheng, L., Zhou, Y. (2004). Closed-loop controlled vortex shedding and vibration of a flexibly supported square cylinder under different schemes. In *Physics of Fluids*, 16(5). <https://doi.org/10.1063/1.1687413>
- [11] K. J. Warner, G. A. Jones, The 21st century coal question: China, india, development, and climate change, *Atmosphere* 10 (8) (2019) 476.
- [12] A.D. IRENA, *Remap 2030: A renewable energy roadmap* (2014).
- [13] M. K. Hossain, M. H. Ali, Transient stability augmentation of pv/dfig/sg-based hybrid power system by parallel-resonance bridge fault current limiter, *Electric Power Systems Research* 130 (2016) 89–102.
- [14] M. K. Hossain, M. H. Ali, Transient stability augmentation of pv/dfig/sg-based hybrid power system by nonlinear control- based variable resistive fcl, *IEEE Transactions on Sustainable Energy* 6 (4) (2015) 1638–1649.
- [15] M. E. et al, *Renewables 2018: global status report*, Worldwatch (2018). [6] M. A. Hossain, H. R. Pota, M. J. Hossain, F. Blaabjerg.
- [16] K. P. Kumar, B. Saravanan, Recent techniques to model uncertainties in power generation from renewable energy sources and loads in microgrids—a review, *Renewable and Sustainable Energy Reviews* 71 (2017) 348–358.
- [17] M. H. Athari, Z. Wang, Modeling the uncertainties in renewable generation and smart grid loads for the study of the grid vulnerability, in: *2016 IEEE Power & Energy Society Innovative Smart Grid Technologies Conference (ISGT), IEEE, 2016*, pp. 1–5.
- [18] G. Rashid, M. H. Ali, Bridge-type fault current limiter for asymmetric fault ride-through capacity enhancement of doubly fed induction machine-based wind generator, in: *2014 IEEE Energy Conversion Congress and Exposition (ECCE), IEEE, 2014*, pp. 1903–1910.
- [19] S. B. Naderi, M. Negnevitsky, A. Jalilian, M. T. Hagh, K. M. Muttaqi, Low voltage ride- through enhancement of dfig-based wind turbine using dc link switchable resistive type fault current limiter, *International Journal of Electrical Power & Energy Systems* 86 (2017) 104–119.
- [20] X.-Y. Xiao, R.-H. Yang, X.-Y. Chen, Z.-X. Zheng, C.-S. Li, Enhancing fault ride-through capability of dfig with modified smes-fcl and rsc control, *IET Generation, Transmission & Distribution* 12 (1) (2017) 258–266.
- [21] Evolution of microgrids with converter-interfaced generations: challenges and opportunities, *International Journal of Electrical Power & Energy Systems* 109 (2019) 160–186.
- [22] M. A. Hossain, H. R. Pota, W. Issa, M. J. Hossain, Overview of ac microgrid controls with inverter interfaced generations, *Energies* 10 (9) (2017) 1300.
- [23] Z.-j. Wang, Z.-z. Guo, Uncertain models of renewable energy sources, *The Journal of Engineering* 2017 (13) (2017) 849–853.