

A Review on Various Soft Robotic Grippers for Grasping Objects

Ujjwal Prajapati¹, Prof. Dr. Tharakeshwar Appala²

¹CAD / CAM / CAE, Dr. Vishwanath Karad MIT WPU, Pune, India

²School of Mechanical Engineering, Dr. Vishwanath Karad MIT WPU, Pune, India

Abstract— Grasping, sorting, or inspecting of products require an end-effector known as grippers attached at the end of a robotic arm or manipulator. Handling of fragile or delicate objects require sophisticated, under-actuated, adaptive, soft grippers that interacts dynamically with environment. The proposed paper will discuss around soft robotic grippers and classify the literature based on objectives, design, mechanical adaptability, and materials used for development.

Keywords—Soft grippers, adaptive, end-effector, mechanical adaptability, grasping.

1. INTRODUCTION

The task of picking and holding the object is called as grasping and exerting force on the object is called as manipulating, and these functions are executed both by robots and animals. Animals and robots use these functions to perform different tasks such as digging, rotating, holding, perching, scratching and locomotion. Moreover, they have sensory information to detect material, texture, temperature, and many other physical properties. In this article the word “Grippers” will be used to indicate the robotic end-effectors.

To directly interact with external environment or foreign objects, robot contains parts through which these tasks can be executed known as end-effectors. Grippers as a part of end-effector plays a significance role between robot arm and work piece. Use of soft grippers in robots for material handling will reduce effect of damage.

Traditionally grippers used to consist of rigid links and heavy actuators. A comprehensive review of different soft robotic grippers is done based on their applications, actuators and materials used. Design for grippers varies from two fingered gripper to anthropomorphic grippers. The motivation for flexibility and dexterity of holding an object, gripper

design fluctuates according to application. Two fingered grippers are usually mechanically simpler and restrict on grabbing uneven shaped object. Anthropomorphic are challenging in design as compared to two fingered grippers. They are mechanically complex, flexible, and difficult in handling soft and deformable objects. The actuation for soft grasping is different in many ways, in this review actuators such as shape memory materials, pneumatic, vacuum, external motors, pulling of embedded cables, and dielectric elastomer actuators. Grippers for grasping soft and fragile objects, advanced materials are discussed consecutively. Material selection is central in design of grippers thus material characteristics such as maximum elastic deformation, viscoelastic, and stiffness are implemented for soft gripper design. The most widely used materials in soft grippers are silicon, shape memory alloy such Ni-Ti alloy (Nitinol), and many other biodegradables, and edible, materials.

2. GRIPPING BY VARIOUS MEANS AND APPLICATION

Various actuation techniques can be preferred for grasping different objects. Researchers investigated many such techniques of soft gripping, here we have focused on our review paper representing soft gripping by different actuators.

2.1 Gripping by Complaint Structures

Complaint structures are operated by motors which are attached to the gripper externally for holding objects. The feature of complaint structures is the non – appearance of segments inside the gripper which passively adapts to the shape of object when externally motor is driven as shown in Fig 1. The main advantage of this structure is high mechanical robustness, moreover motor is connected externally hence size and weight are mostly self - reliant to the geometry of

gripper. Due to this external connection of motor the gripper provides wide range of gripping area selection.

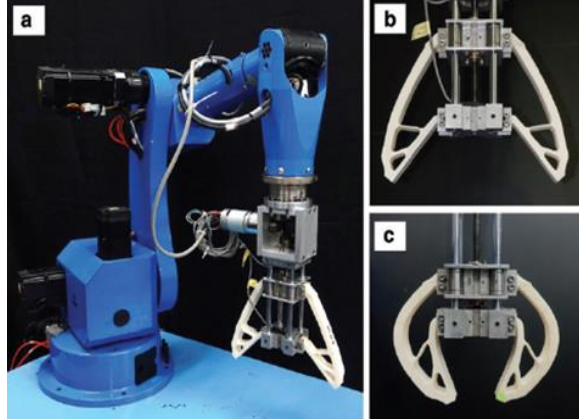

Fig 1: Complaint structure gripper (a) Robotic arm with complaint mechanism gripper, (b) Complaint gripper with open jaws, and (c) Complaint gripper with close jaws [1]

Figure 1a. shows developed underactuated complaint structure soft robotic gripper mounted on a six-axis robotic arm. Figure 1b and 1c shows open jaws and close jaws of gripper respectively. In [1] developed monolithic complaint mechanism by synthesizing topology optimization method. This method is basically used to arrange finest layout of the complaint jaws. The proposed gripper can grasp an object with sizes between 42 and 141mm and maximum payload of 2.1kg.

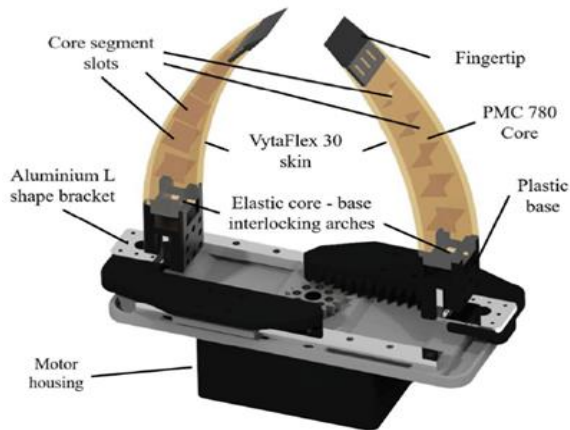

Fig 2. Multi-Segmented core Pre Shaped Adaptive Soft Gripper [2]

Figure 2. shows a parallel two fingered gripper with rack and pinion mechanism actuated by a motor. This is a multi-segmented core pre shaped adaptive gripper (MS-PSA) finger produced with silicone material on its exterior and segmented core in its interior. As discussed in [2], a structure that has the capability to

wrap around various shaped objects thus firmly grasping the objects resisting the frictional force. The material for MS-PSA gripper finger include polyurethane rubber (PMC-780) core with a polylactic acid (PLA) at finger tip.

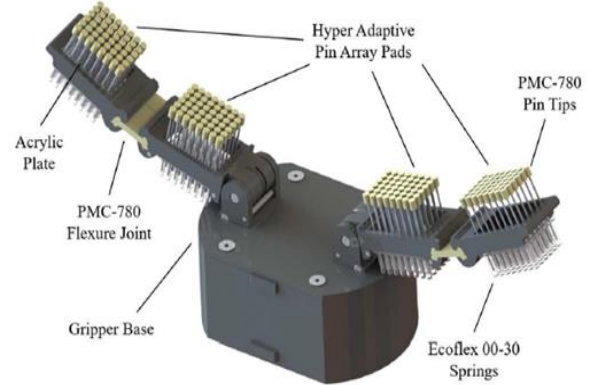

Fig 3. Hyper adaptive (HA) fingered Gripper [2]

Figure 3. depicts hyper adaptive (HA) finger which include array of pins on pads. This contradicts from complaint structures which deforms in all directions equally. The pin array pads helps to grasp the objects by distributing independent forces on contact regions to each pins, thus reducing slippage and ensuring stability.

Shape Memory Materials

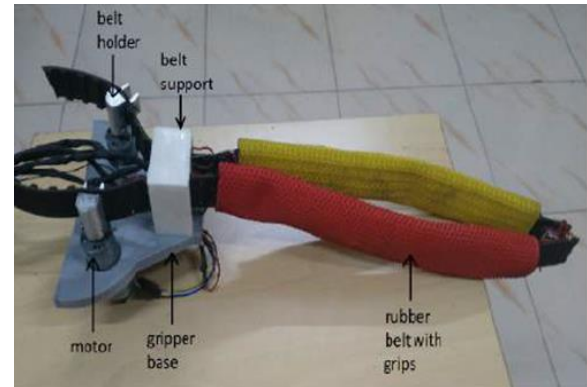

Fig 4. Shape memory alloy (SMA) actuated flexible gripper [4]

In paper [4] researchers presented on SMA actuated dual arm flexible gripper for grasping objects. The gripper is developed using Ni-Ti Nickel Titanium Alloy (Nitinol) having physical tendency to bend when applied external heat. As demonstrated in figure 4, the gripper jaws are covered with rubber belts to create grip when holding an object. Magnets are attached at the tips of gripper attaining locking when the finger gets bend on energizing. The gripper is successfully tested on pipes, metals poles etc.

Gripping by pneumatic, telescopic actuators

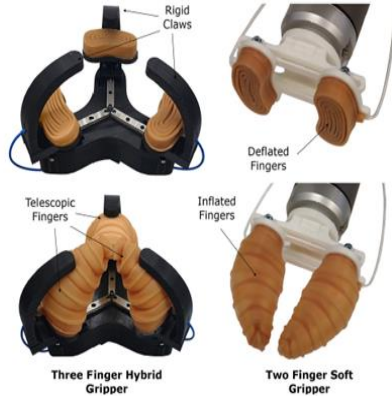

Fig. 5. Telescopic hybrid soft gripper (left) and telescopic soft gripper (right) [3]

As discussed in [3] demonstrated pneumatically actuated telescopic hybrid soft robotic gripper. Figure 5, shows three fingered hybrid gripper (left) and two fingered gripper (right) in deflated (top) and inflated condition (bottom). Researchers presented pneumatically actuated soft fingered gripper with a rigid base, telescopic mechanism that guides on linear rails for varying grasping size of desired object. Urethane rubber is used as material for telescopic mechanism which can operate on pressure of 30kPa. Basically the gripper developed is a combination of soft and rigid structures which facilitates stable grasp of fragile and delicate objects. The curvature design of telescopic gripper helps to grasp wide range of objects and exert significant contact forces.

2.4 Gripping by elastomer actuation

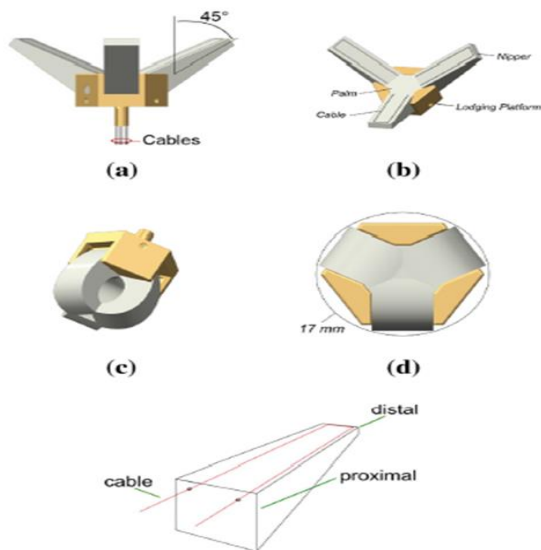

Fig 6. Soft claw gripper: (a) Front view (b) isometric View (c) closed configuration (d) top view (e) actuator arrangement [6]

In paper [6] researchers proposed a soft robotic gripper made entirely from elastomeric material. The paper mainly focuses on minimal invasive surgery but can be scaled to other grasping application of fragile and delicate items. As shown in fig. 6 three fingered soft robotic gripper is made of silicone material because of its flexibility and elastic properties. The fingers are sloped and positioned such that the palm is located towards downward and when cables are pulled the grippers get closed hence grasping is executed. When the cables are released the fingers get back to open position due to elastic properties of silicone material.

2.5 Gripping by dielectric elastomer

Dielectric elastomers are type transducers that fundamentally convert electrical energy to mechanical energy. Researchers in [5] developed a soft robotic gripper using this technology. Dielectric elastomers have capability to develop electro- adhesion force by generating electrostatic energy which allow to grab any deformable object creating a soft gripping mechanism. This gripper only weighs 1.8g in weight and has the capacity to lift an object 400 times of its own weight. When an external voltage is applied dielectric elastomer behaves as a yielding capacitor resulting in expansion. Electroactive polymer is proposed as a material in developing the gripper because of its property to get deform under electric impulse and for implementing flexible actuation mechanism. Figure 7. Shows various objects lifted through dielectric elastomer gripper.



Fig 7. Dielectric gripper lifting various sized objects [5]

2.6 Bio Inspired Soft Gripper

As discussed in [7] authors developed three types of actuation mechanisms from various bio-inspired

design. Pneumatic actuation is used for developing one fingered gripper, SMA i.e., Shape Memory Alloy is used for two and three fingered gripper and electromagnetic actuation is used for developing two jaw grippers. The pneumatic actuated one fingered and SMA actuated three and two fingered grippers are human hand and scorpion pedipalps design respectively. Moreover, electromagnetic actuation gripper design is an inspiration of scorpion pedipalps. Pneumatic gripper has pockets with an inlet to supply compressed air. When the air is pumped the gripper gets inflated and bend on one side by getting wrap on an object for grasping. Figure 8. Shows SMA actuated human three fingered inspired gripper. The base is made of Acrylonitrile Butadiene Styrene (ABS) material and the fingers are made of silicone material. The scorpion inspired is two-way SMA actuated gripper. Electromagnet actuated is fourth soft gripper design. At the tips of finger electromagnets are placed such that the poles of the magnets are faced opposite. When an electric supply is made, the electromagnets get attracted to each other and the fingers get close, hence exhibiting gripping mechanism.

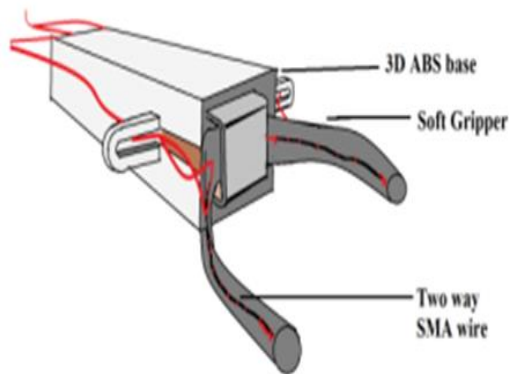

Fig 8. SMA actuated scorpion inspired gripper [8]

2.7 Gripper by Fluidic Elastomer Actuation (FEA)

In [8] paper researcher proposed gripping actuation by low pressurized fluid. The basic structure of gripper consists of elastomer with soft and flexible properties. The structure is divided by a flexible constraint. When low pressurized fluid is pumped into the gripper finger stress is generated in the elastic material of the finger and bending is executed developing gripping mechanism. Figure 9 shows the Fluidic elastomer actuator.

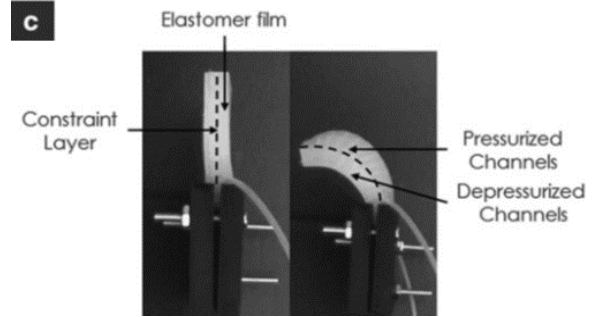

Fig 9. Gripper actuated by Fluidic Elastomer [8]

2.8 Gripper for Underwater application

Researchers in paper [9], presented a gripper for underwater applications. The gripper is trident shaped three jaw gripper typically developed for underwater environmental conditions. The consists of six motors each connected with a worm gear arrangement to have desired torque and speed ratio as output. Tactile sensors are mounted on each gripper finger covered under silicone layer for water resistance. Furthermore, silicone act as soft touch skin for gripper and increasing friction between object and gripper finger, thus increasing stability.



Fig 10. Under water application gripper [9]

3.CONCLUSIONS

3.1 Gripping by complaint mechanism:

The proposed design is 3D printed complaint-based mechanics gripper. The main advantage of this mechanism is that it reduces complex structure moreover it reduces space and weight, hence is much compatible to use and much flexible to space constrained area of application. The design can be optimized by reducing dimensions. Reducing the linkages between the outer layer of the gripper reduces stress and increases strain hence, to grip small object as per requirement the gripper jaws can be designed.

3.2 Shape Memory Material Gripper:

Shape Memory Alloy (SMA) actuated gripper is developed using Ni-Ti (Nitinol) Nickel-Titanium alloy as a material. Applications of SMA can be widely used as per requirements and accordingly different structural designs can be developed.

3.3 Gripping by pneumatic, telescopic actuator:

The proposed design of pneumatically actuated telescopic gripper is developed to grasp different fragile and delicate objects. The structure is designed in such a way that various size and shape of object can be grasped easily by just sliding the jaws along the linear rails. Moreover, the gripper is a combination of rigid and soft structure thus telescopic structure can be disposed after many uses.

3.4 Gripping by elastomer actuation:

The gripper is completely developed for soft application purpose. The base and the fingers can be changed suitable for various size object grabbing. The gripper can be used in medical applications because of its soft interaction with the surrounding.

3.5 Gripping by dielectric elastomers:

Dielectric elastomer property of converting electrical energy to mechanical energy motivated the researcher to develop a gripping mechanism based on DE. Due to its lightweight structure and feature of lifting object more than 400times of its own weight the gripper can be paved to many other applications.

3.6 Bio Inspired soft robotic gripper:

For gripping various objects different bioinspired soft grippers are studied and various mechanisms from bio inspiration can be developed and applied accordingly.

3.7 Gripping by Fluidic Elastomer Actuation (FEA):

Developing different structures for gripping mechanisms, actuation through fluid can be imposed. Moreover, the grasping power can adjust according to fluid pressure applied.

REFERENCE

[1] Liu, Chih-Hsing & Chen, Ta-Lun & Chiu, Chen-Hua & Hsu, Mao-Cheng & Chen, Yang & Pai, Tzu-Yang & Peng, Wei-Geng & Chiang, Yen-Pin. (2018). Optimal Design of a Soft Robotic

Gripper for Grasping Unknown Objects. *Soft Robotics*. 5. 10.1089/soro.2017.0121.

- [2] Chang Che-Ming, Gerez Lucas, Elangovan Nathan, Zisimatos Agisilaos, Liarokapis Minas (2019). On Alternative Uses of Structural Compliance for the Development of Adaptive Robot Grippers and Hands. *Frontiers in Neurorobotics*. 10.3389/fnbot.2019.00091
- [3] Gerez, Lucas & Chang, Che-Ming & Liarokapis, Minas. (2020). Employing Pneumatic, Telescopic Actuators for the Development of Soft and Hybrid Robotic Grippers. *Frontiers in Robotics and AI*. 7. 601274. 10.3389/frobt.2020.601274.
- [4] Pusalkar, Neha & Karmakar, Sourav & Aggrawal, Rohit Flexible Gripper. 1-6. 10.1145/3352593.3352669.& Mali, Pravin & Singh, Akash & Sarkar, Abhishek & Krishna, Madhava. (2019). SMA Actuated Dual Arm
- [5] Patel, Mills & Khamar, Rudrax & Shah, Akshat & shah, Tej & Soneji, Bhavik. (2021). Dielectric Elastomer Grippers. *International Journal of Engineering and Advanced Technology*. 10. 33-36. 10.35940/ijeat.E2548.0610521.
- [6] Ciuti, Gastone & Rateni, Giovanni. (2015). Design and development of a soft robotic gripper for manipulation in minimally invasive surgery: a proof of concept. *Meccanica*. 50. 10.1007/s11012-015-0261-6.
- [7] Karmakar, Sourav & Sarkar, Abhishek. (2019). Design and Implementation of Bio-Inspired Soft Robotic Grippers. 1-6. 10.1145/3352593.3352618.
- [8] Marchese, Andrew & Katzschmann, Robert & Rus, Daniela. (2015). A Recipe for Soft Fluidic Elastomer Robots. *Soft Robotics*. 2. 7-25. 10.1089/soro.2014.0022.
- [9] Bemfica, J.R. & Melchiorri, Claudio & Moriello, Lorenzo & Palli, Gianluca & Scarcia, Umberto & Vassura, G. (2013). Mechatronic Design of a Three-Fingered Gripper for Underwater Applications*. *IFAC Proceedings Volumes (IFAC-Papers Online)*. 46. 307-312. 10.3182/20130410-3-CN-2034.00080.
- [10] Shahriari, Mohammadali & El-Sayed, Abdul-Rahman. (2016). State of the Art Robotic Grippers and Applications. *Robotics*. 5. 10.3390/robotics5020011.
- [11] Hasan, Waris & Gerez, Lucas & Liarokapis, Minas. (2020). Model-Free, Vision-Based Object

- Identification and Contact Force Estimation with a Hyper-Adaptive Robotic Gripper. 10.1109/IROS45743.2020.9340952.
- [12] Shintake, Jun & Cacucciolo, Vito & Floreano, Dario & Shea, Herbert. (2018). Soft Robotic Grippers. *Advanced Materials*. 30. 1707035.10.1002/adma.201707035.
- [13] Galloway, Kevin & Becker, Kaitlyn & Phillips, Brennan & Kirby, Jordan & Licht, Stephen & Wood, Robert & Gruber, David. (2016). Soft Robotic Grippers for Biological Sampling on Deep Reefs. *Soft Robotics*. 3. 10.1089/soro.2015.0019.
- [14] Kontoudis, George & Liarokapis, Minas & Vamvoudakis, Kyriakos G. (2019). An Adaptive, Humanlike Robot Hand with Selective Interdigitation: Towards Robust Grasping and Dexterous, In-Hand Manipulation.10.1109/Humanoids43949.2019.9035037.
- [15] A., Sainul & Deb, Sankha & Deb, Ak. (2016). A Three Finger Tendon Driven Robotic Hand Design and Its Kinematics Model. 10.1007/978-81-322-2740-3_30.
- [16] Kodippili Arachchige, Dimuthu & Chen, Yue & Walker, Ian & Godage, Isuru. (2020). A Novel Variable Stiffness Soft Robotic Gripper.
- [17] Saliba, Michael & Silva, C.W. (1991). An innovative robotic gripper for grasping and handling research. *European Psychiatry - EUR PSYCHIAT*. 2. 975 - 979 vol.2. 10.1109/IECON.1991.239158.
- [18] Vagaš, Marek & Varga, Jozef. (2013). Design of Modular Gripper for Industrial Robot. *Applied Mechanics and Materials*. 436. 351-357.10.4028/www.scientific.net/AMM.436.351.
- [19] Kolluru, Ramesh & Valavanis, K.P. & Smith, Stanford & Tsourveloudis, Nikos. (2000). Design and analysis of a reconfigurable robotic gripper for limp material handling. *Proceedings - IEEE International Conference on Robotics and Automation*. 2. 1988 - 1993 vol.2. 10.1109/ROBOT.2000.844886.
- [20] Lee, Chiwon & Kim, Myungjoon & Kim, Yoon & Hong, Nhayoung & Ryu, Seungwan & Kim, Sungwan. (2017). Soft robot review. *International Journal of Control, Automation and Systems*. 15. 10.1007/s12555-016-0462-3.