

Minimizing Power Loss in a Flywheel Energy Storage System Using Closed Loop for EV Applications

P. Kavitha¹, K.S. Kavin², P. Subha Karuvelam³, P. Malathi⁴

^{1,2,4}*Research Scholar, Department of Electrical and Electronics Engineering, Government College of Engineering, Tirunelveli, Tamilnadu-627007*

³*Professor, Department of Electrical and Electronics Engineering, Government College of Engineering, Tirunelveli, Tamilnadu-627007*

Abstract—Energy storage devices play an important role in the field of Power Electronics. The most common device that we use today is the battery. Recently Flywheels have become an alternative to batteries. The flywheels store energy as rotational energy which can be later released as electrical energy. They have many advantages over the conventional storage systems and hence have found application in several areas. Switching loss is a main problem in all energy storage systems. In this paper, we present a topology with a combination of fast turn-off Silicon Controlled Rectifier (SCR) and Insulated Gate Base Transistor (IGBT) to achieve zero switching losses through Zero Voltage Transition (ZVT) and Zero Current Transition (ZCT) techniques. It ensures zero switching power loss for both buck and boost modes of operation. The system is simple and achieves ZSPL during both turn on and turn off of the device resulting in improved efficiency and reduced EMI problems.

Index Terms—Flywheel, Zero Voltage Transition (ZVT), Zero Current Transition (ZCT), Fast turn Off SCR, Energy storage.

I. INTRODUCTION

Flywheels as a device for energy storage has leading role in power electronics. Therefore, several investigations have been conducted during the recent past in order to make flywheels a reliable and cost effective method for short term energy storage in highly sensitive equipments. Several domains of engineering have contributed to develop flywheels of high efficiency, with carbon fibre composites, superconducting bearings and vacuum encased frictionless machinery and power electronic switching. Consequently the theoretical energy storage capacity of flywheels has been enhanced and they can have a stable operation and can function as electromechanical batteries suitable for various applications. In a Flywheel Energy Storage System (FESS), the

electrical energy input is transformed into mechanical energy which is stored in a rotating flywheel that is driven by an integrated motor/generator and it is converted to electrical energy through a bi-directional converter. Most modern type of flywheels consist of a massive rotating cylinder that is, a rim attached to a shaft that is supported on a stator by magnetically levitated bearings. To maintain efficiency, the flywheel system is operated in a vacuum to reduce drag. The lifetime of the flywheel is almost independent of the depth of discharge and discharge cycle. The state of charge in an FESS can easily be measured, since it is given by the rotational velocity. Another major advantage is its ability to handle high power levels. A typical FESS consists of a dc source, a bi-directional converter, and an electrical machine coupled to the flywheel. The most suitable electrical machines for this type of applications are, permanent magnet synchronous machine and the switched reluctance machine. This machine act as a motor when energy is being stored in the flywheel and as a generator when the same energy is being harvested. High power density and efficiency are important requirements of energy storage systems [1]. High power densities in switched mode power converters can be achieved by switching at high frequencies. Higher efficiencies can be achieved by taking appropriate measures to reduce the losses. Switching power loss can be reduced either by Zero Voltage Switching (ZVS) method or Zero Current Switching (ZCS) method depending upon whether the voltage across the device is made zero during turn ON or current through the device is made zero during turn OFF transition.

Elaborate research work has been carried out during the past several years on Zero Current Transition / Switching, and Zero Voltage Transition / Switching

schemes. Gurumurthy et al [2], Mao et al [3], Solero et al, Li & Lee [5], and Bodur & Bakan [6] describe the Zero Current Transition (ZCT) techniques in high power applications. Gang Ma et al [1], Xiao et al [7], Duzmez et al [8], Mohammadi et al [9] and Ying-Chun Chuang & Yu-Lung Ke [10] deal with Zero Voltage Transition (ZVT) type of converters and their applications. Different topologies and configurations have been proposed so as to minimize switching losses. For example Russi et al [11]a proposed to use snubber assisted turn off of the switching device. This helps in reducing the loss, but it does not eliminate loss. A mathematical expression has been developed by Russi et al [12]b to determine the occurrence of soft-switching for a general topology of Zero Voltage Transition (ZVT) converters for choosing appropriate values of inductance and capacitance for the auxiliary resonant branch ensuring ZVT.

II. THE PROPOSED SYSTEM

Fig. 1 is block diagram of the proposed system. Here, we use a combination of Silicon Controlled Rectifier (SCR) and Insulated Gate Base Transistor (IGBT). The IGBT is used as the main device for carrying the load current and the SCR as auxiliary device. Since the current impulse in the resonant circuit has a natural zero crossing, SCR is a good choice for auxiliary device. The device we store energy is the Flywheel Energy Storage System. The loss mainly occurring in the storage device is drag loss, friction loss, eddy current loss etc. These can be reduced by using the flywheel energy storage device. Mainly, the flywheel energy storage device consists of a vacuum pump, magnetic bearing, rotor, etc. Drag loss can be reduced by providing a vacuum enclosure for the rotating parts of the system. Both eddy current and hysteresis loss can be reduced using a two pole machine as well as by using low specific core material.

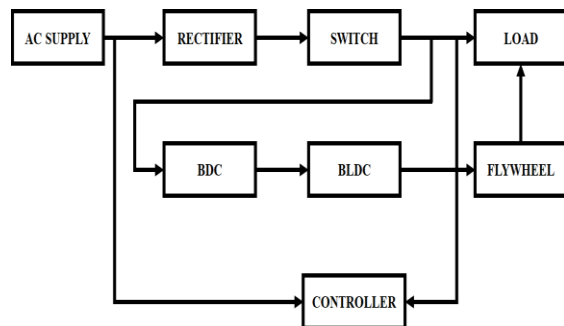

Fig.1. Block Diagram of the proposed system

A. Working Principle

The circuit diagram of the proposed system is as shown in Fig. 2. When an AC supply is given, it goes to the rectifier. The rectifier converts AC supply to the DC supply. Due to this supply, the dc bus is energized. Mainly 400V supply is required to energize the dc bus. A part of the supply passes to the capacitive filter. This capacitive filter reduces the amount of ripple voltage to a level that is an acceptable one. This supply is then passed to the thyristor. The thyristor will control the power that is going to the load. Here small switches are required to initiate the power flow. These small switches are called as auxiliary switches. The switching assisted by Zero Current Transition (ZCT) is realised through the oscillating action of the LC circuit. The FES machine is connected to the dc bus through the switches S_1 and S_2 . In the switch, the diodes are connected in anti-parallel. If the switches are turned off, the diodes began to conduct. This makes the main device to go from ON state to OFF state when voltage across it is zero. And from ON state to OFF state when the current through it is zero. In the load itself there is a chance to the leakage of current. It is measured and taken out. It is given again with the supply.

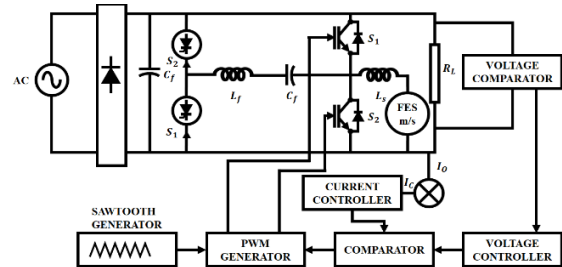

Fig.2. Circuit Diagram

L_f	Resonant circuit inductance
C_f	Resonant circuit capacitance
R_L	Load resistance connected to across dc bus
I_c	Current through main device
I_o	Output current

III. SIMULATION RESULTS

Simulation of the proposed topology was carried out using MATLAB/Simulink software. The wave forms obtained for speed, armature current, field current and torque are given in Fig. 3. The speed of the flywheel increases corresponding to the increase in the energy stored. The inverse relation between field current and

armature current is evident from the second and third wave forms.

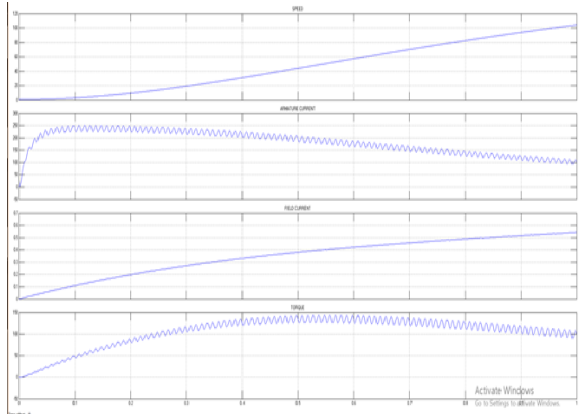

Fig.3. Simulation Results of FES Machine

IV. CONCLUSION

This project is about minimizing switching power loss in flywheel energy storage system. In the ON state of supply, the flywheel machine begin to store the voltage which is already rectified through the rectifier. This energy is stored in the Flywheel machine in the form of kinetic energy and is used to rotate the rotor part of the machine. As energy stored increases, the rotational speed of the rotor increases. When a particular amount of energy is stored, the rotor continues to rotate the same speed. When the armature current increases, the field current decreases and vice versa.

REFERENCES

- [1] G. Ma, W. Qu, G. Yu, Y. Liu, N. Liang and W. Li, "A Zero-Voltage Switching Bidirectional DC-DC Converter With State Analysis and Soft-Switching-Oriented Design Consideration", *IEEE Trans. Ind. Electron.*, vol. 56, no. 6, pp. 2174-2184, June 2009.
- [2] S. R. Gurumurthy, V. Agarwal and A. Sharma, "Apportioning and Mitigation of losses in a Flywheel Energy Storage system", in *Conference Proc. IEEE PEDG 2013*, pp. July 2013.
- [3] H. Mao, F. C. Lee, X. Zhou and D. Boroyevich, "Improved zero-current transition converters for high power applications", *IEEE Trans. Ind. Appl.*, vol. 33, no. 5, pp. 1220-1232, Sept./Oct. 1997.
- [4] L. Solero, D. Boroyevich, Y. P. Li and F. C. Lee "Design of resonant circuit for zero current transition techniques in 100kW PEBB applications," *IEEE Trans. Ind. Appl.*, vol. 39, no. 6, pp. 1783-1794, Nov./Dec. 2003.
- [5] Y. Li and F. C. Lee, "A comparative study of a family of zero-current transition schemes for three-phase inverter applications," in *Proc. IEEE, APEC, 2001*, pp. 1158-1164.
- [6] H. Bodur, A. F. Bakan, "An Improved ZCT-PWM DC-DC Converter for High-Power and Frequency Applications," *IEEE Trans. Ind. Electron.*, vol.51, no.1, pp. 89- 95, February 2004
- [7] H. F. Xiao, X. P. Liu and K. Lan, "Zero-Voltage-Transition Full-Bridge Topologies for Transformer less Photovoltaic Grid-Connected Inverter," *IEEE Trans. Ind. Electron.*, vol. 61, no. 10, pp. 5393-5401, October 2014
- [8] S. Dusmez, A. Khaligh and A. Hasanzadeh, "A Zero-Voltage-Transition Bidirectional DC/DC Converters," *IEEE Trans. Ind. Electron.*, vol. 62, no. 5, pp. 3152-3162, May 2015.
- [9] M. R. Mohammadi and H. Farzanehfard, "New Family of Zero- VoltageTransition PWM Bidirectional Converters with Coupled Inductors," *IEEE Trans. Ind. Electron.*, vol. 59, no. 2, pp. 912-919, February 2012.
- [10] Ying-Chun Chuang and Yu-Lung Ke, "High-Efficiency and Low -Stress ZVT-PWM DC-to-DC Converter for Battery Charger" *IEEE Trans. Ind. Electron.*, vol. 55, no. 8, pp. 3030-3037, August 2008.
- [11] J. L. Russi, V. F. Montagner, M. L. S. Martins and H. L. Hey, "A Simple Approach to Detect ZVT and Determine Its Time of Occurrence for PWM Converters," *IEEE Trans. Ind. Electron.*, vol. 60, no. 7, pp. 2576-2585, July 2013.
- [12] J. L. Russi, V. F. Montagner, M. L. S. Martins and H. L. Hey, "A Simple Approach to Detect ZVT and Determine Its Time of Occurrence for PWM Converters," *IEEE Trans.*, vol. 60, no. 7, pp. 2576- 2585, July 2013.