

# Microcontroller Based Portable Webserver

Mr. Sachin S. Rindhe<sup>1</sup>, Dr. Prakash G. Burade<sup>2</sup>, Prof. Deepak Deshpande<sup>3</sup>, Mrs. Ashwini S Rindhe<sup>4</sup>, Ishit Sachin Rindhe<sup>5</sup>

<sup>1</sup>*Principal Program Manager, MathWorks India Private Limited, Bangalore, India*

<sup>2</sup>*Dean School of engineering and technology E&E Department Electronics & Telecommunication Department, Sandeep University, Nashik*

<sup>3</sup>*Electronics and Telecommunication Department, Gurunanak Institute of Engineering & Technology, Nagpur, Maharashtra, India*

<sup>4</sup>*Lecturer VIBGYOR High Bangalore, India*

<sup>5</sup>*CPS, Bangalore*

**Abstract:-** In this paper, study is carried out to explore use a microcontroller to develop portable web server. This portable webserver can be used for webpage hosting over intranet and also can be used for remote data monitoring. Microcontroller used to make cost effective, maintainable and portable solution. The innovation is in the technology to support webserver application by microcontroller.

Webpages that need to brows are stored in memory of microcontroller and dedicated IP address is assigned to each device. To access webpages which are stored in memory of microcontroller, open internet explorer (IE) and type IP address of devices. Home page, which is stored in the device, will be open from where user can access all webpages and this device act as webserver.

**Keywords-** Microcontroller, Webserver, portable.

## I. INTRODUCTION

The main objective is to design “Microcontroller based Portable webserver” which can be used in multiple application and for remote data monitoring on web pages

[1] The term webserver, can refer to either the hardware (the computer) or the software (the computer application) that helps to deliver web content that can be accessed through the Internet.

The most common use of web servers is to host websites, but there are other uses such as gaming, data storage, running enterprise applications, handling email, FTP, or other web uses. The primary function of a web server is to store, process and deliver web pages to clients. The communication between client and server takes place using the Hypertext Transfer

Protocol (HTTP). Pages delivered are most frequently HTML documents, which may include images, style sheets and scripts in addition to text content.

A user agent, commonly a web browser or web crawler, initiates communication by making a request for a specific resource using HTTP and the server responds with the content of that resource or an error message if unable to do so. The resource is typically a real file on the server's secondary storage, but this is not necessarily the case and depends on how the web server is implemented. While the primary function is to serve content, a full implementation of HTTP also includes ways of receiving content from clients. This feature is used for submitting web forms, including uploading of files.

Presently website hosing needs big servers and have regular maintenance and not portable.

For data communication in industries, many communication protocols are used in industries such as RS485, DNP3, Serial, CAN, LIN which have specified wiring requirement and need initial installation cost and maintenance cost.

Proposed microcontroller based portable webserver in which web pages stored in microcontroller and can be hosted to form portable webserver. We have two method of storing web pages in microcontroller memory, first is store web pages in flash file system and second store web pages in hex array format in code. In order to make a webserver in your local network through the DSL router, internal IP address need to enter in bower.

Microcontroller based webserver can also be used for remote data monitoring purpose. Process data or parameter can be monitored on web pages.

Microcontroller will read data from sensor and will process raw data and final data will be sent to HTTP server and HTTP sever will send data to webpages over TCP protocol, by microcontroller. As HTTP server are simplify protocol specific setting no additional wiring needed like CAN. LIN, Serial thus webserver can be used to monitor remote data. With proposed method, portable webserver can be designed which will be portable and will have low development and maintenance.

## II. OBJECTIVE

The main objective of the project is to design “Microcontroller based Portable web server” which can be used in multiple applications for webpage hosting and remote data monitoring on web pagars.

## III. EXISTING METHOD

Webserver: Webserver contains hardware which are big computer or the software (the computer application) that helps to deliver web content that can be accessed through the Internet. These webserver are bulky and need parodic maintenance.



Figure.1: Webserver hardware Photo

Data interface: Many protocols are used in industrial data communication and parameter monitoring such as CAN, MODBUS, DNP3, LIN, SPI, RS-232 which add installation cost, maintenance cost and wiring complexity and protocol understanding and setting complexity such as baud rate mode of working.

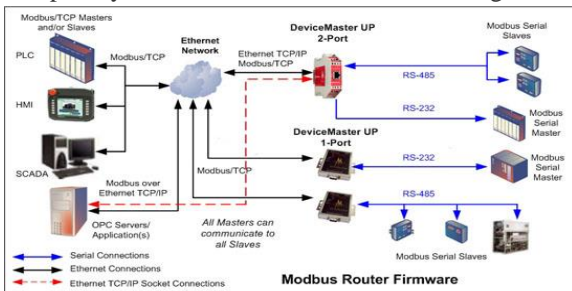

Figure.2: Devices interface photo

## IV. PROPOSED METHOD

Webserver: Webserver contains hardware and software. Microcontroller and its memory acts as a hardware and webpages created in HTML language acts as software. Now to make webserver webpages need to host from microcontroller. To host pages from microcontroller it need to save web pages any memory location.

We have two method of storing web pages in microcontroller memory,

- i) store web pages in flash file system external memory
- ii) store web pages in hex array format in code memory – internal memory.

Webpages prepared in HTML will be stored in microcontroller’s internal memory. Using RTOS, each microcontroller will be assigned to unique static IP address and HTTP server will be created. To brows webpages, IP address will be entered in browser and request will receive over HTTP server over TCP protocol and request will be send to microcontroller and request will be served by opening requested webpage.

Data interface: Multiple data monitoring devices can be connected over LAN and data can be monitored over webpages. With this approach multiple protocols are not needed for data communication, and simplifies wiring complexity. Devices will read data from sensor, which is processed by microcontroller by running algorithm on raw collected data. Parameter such as temperature, pressure can be monitored on webpages using HTTP server and TCP protocol.

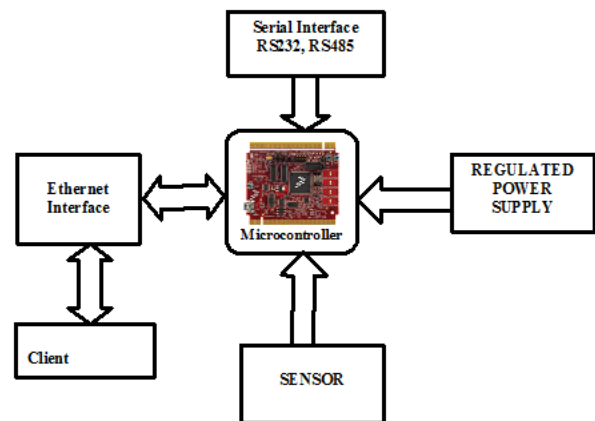

Figure.3: Hardware Block Diagram of webserver

- For implementation of webservice controller is of K60 family from Freescale, which is able to simplify software development greatly by dividing the application into a series of tasks and events, and improve system reliability by ensuring real time performance.
- Web pages developed in HTML language will be stored in coding in form of hex array. Conversion of html to Hex array will be done by free tool provided my MQX RTOS.

## V. RESULTS

Compiled design generated HEX file, which is flashed in memory of microcontroller. IP address of device is entered in Internet Explorer and observed that home page opened from webservice after processing from microcontroller memory.

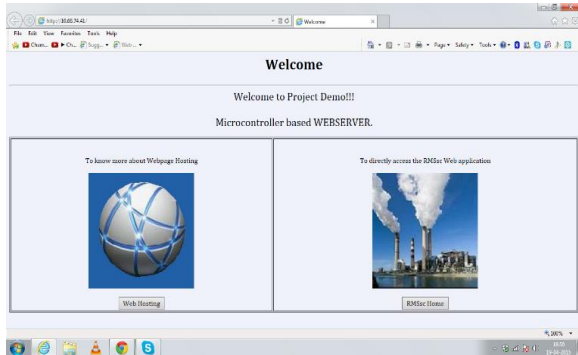

Figure.4. Home page of webservice

Figure 4. shows result received during experimentation. First home page is opened after entering IP address. Two bottom can be seen on home page. When button ‘Web Hosting’ clicked then webpage hosting page opened. When button ‘RMSsc Home’ pressed webpage RMSsC opened. Back to home page from any page can be done via using ‘Back’ link.

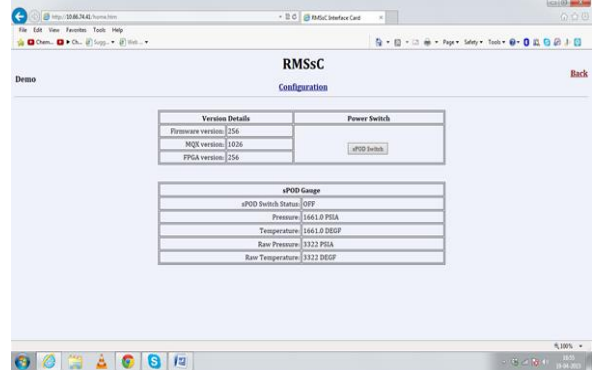
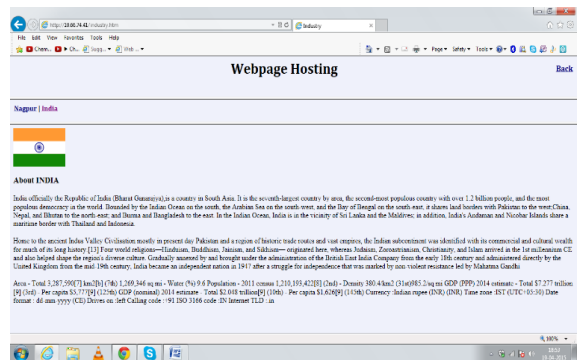

Figure.5. Results of navigation from homepage

## VI. CONCLUSION

This paper has presented the research being undertaken to investigate the suitability of using microcontroller technology for webservice application. Microcontroller targets application across consumer, commercial, industrial and government market worldwide. Microcontroller can be used to develop webservice which can be used across industry for web page hosting and remote data monitoring purpose. This technology best suits for remote monitoring system due to its low development and maintenance cost.

## REFERENCE

- [1] [http://en.wikipedia.org/wiki/Web\\_server](http://en.wikipedia.org/wiki/Web_server).
- [2] Zhu Fande; Inf. Eng. Coll., Yangzhou Univ., Yangzhou, China; Chen Hongjian “µC Linux-based WEBSERVER realization on ARM platform” Computing, Communication, Control, and Management, 2009. CCCM 2009. ISECS International Colloquium on (Volume:1)
- [3] Wang Zhenxing ; Dept. of Comput. Sci., Shanghai Second Polytech. Univ., Shanghai, China; Ren XianYi “A Study on Cgi of Embedded Webservice” Computer Science and Computational Technology, 2008. ISCSCT '08. International Symposium on (Volume:1)
- [4] Fei Xiao; Coll. of Math. & Comput. Sci., Huanggang Normal Univ. Huanggang, Huanggang, China; Zemin Zhu” Research of Embedded WebServer Based on CAN-TCP/IP Gateway” Intelligence Science and Information Engineering (ISIE), 2011 International Conference on
- [5] Zhenxing Wang; Dept. of Comput. Sci., Shanghai Second Polytech. Univ. Shanghai, Shanghai; Linxiang Shi; Zhongyuan Liu; Chuanqun Jiang “Embedded Web

Server and Database Based on Wap” Computer and  
Automation Engineering, 2009. ICCAE '09.  
International Conference on  
[6]<http://www.freescale.com/webapp/sps/site/overview.jsp?code=MQXRTOS>  
<http://en.wikipedia.org/wiki/MQX>  
[http://en.wikipedia.org/wiki/Web\\_server](http://en.wikipedia.org/wiki/Web_server)