

# Design and Implementation of WIU for CAN/WLAN/CAN Bridge

Rohit D.Patil, Prof. V. D. Shinde

*Department of Electronics & Telecommunication, R.M.D Sinhgad School of Engineering, Pune, India*

**Abstract**— Hybrid network of wired and wireless technology has become hot topic research as a result of increasing demands in applying wireless network for industrial application. Hybrid network introduces different delay characteristic, depending on what technology that compose the hybrid network. This paper presents a sample design and implementation of a CAN/WLAN/CAN interworking system using Wireless Interworking Units (WIU) that are capable of connecting remote CAN 2.0B nodes over IEEE 802.11b WLAN. This provides a straightforward solution to extend the size of distributed area of CAN networks and enables the CAN networks to communicate with other LANs utilising a low cost technology with high data rates.

**Index Terms**- CAN, WIU, WLAN

## I. INTRODUCTION

The Controller Area Network (CAN) is mainly employed in distributed real-time control applications. Increasing use of several CAN networks in modern industrial plants results in need for interworking between CAN networks as well as between CAN and other major public/private networks [1-4]. There may be certain difficulties in some industrial scenarios where a traditional wired backbone is deployed to provide this type of required interconnection functions. Instead, having a wireless backbone as an alternative in such environments to interconnect CAN networks would be exceptionally valuable [1-3]. One wireless network which currently provides the features needed in an industrial control environment, that is, easy integration with several communication systems and capability to ensure critical time constraints, is the IEEE 802.11 standard. This work presented includes a sample design and implementation of a CAN/WLAN/CAN interworking system utilising Wireless Interworking Units (WIU) proposed in [2, 3]. The organization of this paper is as follows. Section 2 briefly introduces CAN and IEEE 802.11b WLAN. Section 3 describes block diagram of the WIU and its structure employed in interconnection of the CAN segments using IEEE 802.11b WLAN. The CAN/IEEE802.11b/CAN algorithm is presented in Section 4.

## II. BACKGROUND: CAN AND IEEE 802.11 WLAN

[5] and [6] supply a detailed overview of the CAN features that can be summarized as high speed serial interface, low cost physical medium, short data lengths, fast reaction times and high level of error detection and correction. CAN utilises the Carrier Sense Multiple Access with Collision Detection (CSMA/CD) as the arbitration mechanism to enable its attached nodes to have access to the bus. As CAN employs a priority based bus arbitration process, the node with the highest priority will continue to transmit without any interruption. There are two versions of CAN exist and they only differ in the size of identifier. The identifier field serves two purposes: assigning a priority for the transmission and allowing message filtering upon reception. Figure 1 shows the CAN 2.0B message format utilised in the WIU.

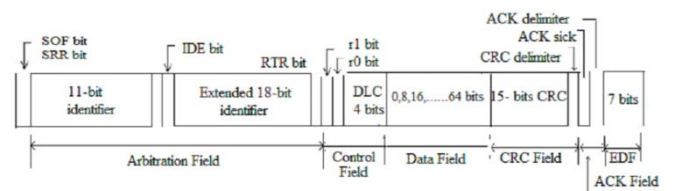

Fig.1 CAN 2.0B message format

IEEE 802.11 WLAN is a local area network implemented without wires. The main advantages of WLAN are mobility and cost saving installation. Any WLAN aims to offer all the features and benefits of traditional LAN technologies (e.g., Ethernet and Token Ring) but without the limitations of being tethered to a cable [7-8]. IEEE 802.11 employs Carrier Sense Multiple Access/ Collision Avoidance (CSMA/CA) as the channel access method and operates in the 2.4 GHz unlicensed ISM (Industrial, Scientific and Medical) band. Figure 2 shows IEEE 802.11b frame that consists of a PLCP preamble, PLCP header, and MAC Protocol Data Unit (MPDU), utilized also in the WIU. [7]

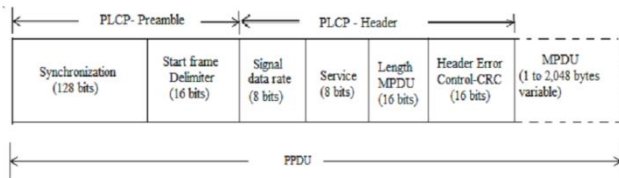

Fig. 2 IEEE 802.11b DSSS PCLP packet format

### III. BLOCK DIAGRAM OF CAN/IEEE 802.11B/CAN WIU UNIT

The Wireless Internetworking Unit (WIU) interconnects two CAN2.0B networks communicating through IEEE 802.11b. The WIU has two ports. Each port of WIU has a different protocol, frame/message format, and frame reception/ transmission mechanism. Thus, the processes to be performed at each port of the WIU are different. Fig 3 and 4 shows the 2 CAN network which communicate through WLAN.

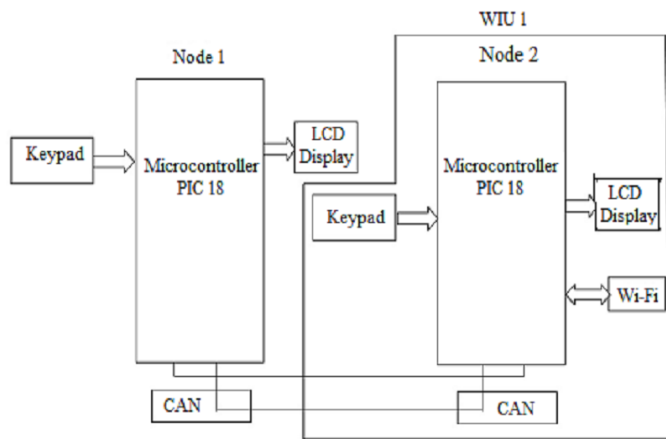

Fig. 3 CAN Network 1 with WIU

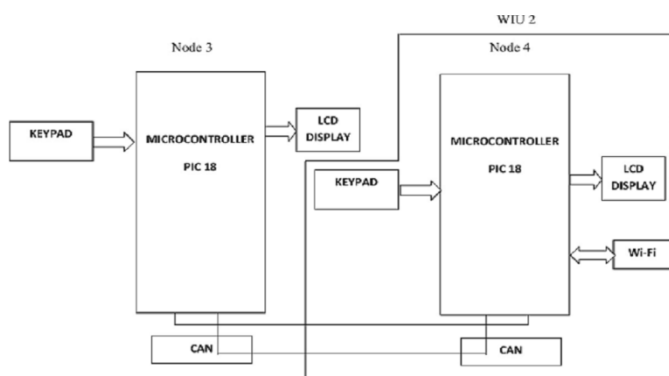

Fig. 4 CAN Network 2 with WIU

Main function of the Wireless Internetworking Unit is that the Protocol Data Units (PDU) of the CAN messages are

encapsulated within those of the IEEE 802.11b DSSS frames to be carried over wireless channels. Since a CAN 2.0B message easily be fitted into one IEEE 802.11b frame MPDU (Figure 5). Thus, neither segmentation / reassembly of CAN messages nor data compression is necessary for carrying a CAN message in one IEEE 802.11 frame. At the destination WIU, preamble and header parts of the IEEE 802.11b frames are stripped off, and the CAN messages extracted from the IEEE 802.11b MPDUs can be processed.

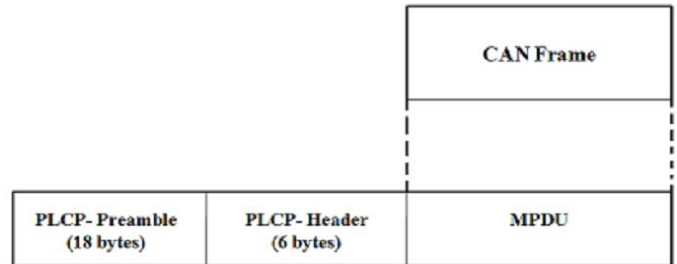

Fig. 5 Encapsulation of CAN 2.0B message into an IEEE 802.11b Frame

IV. PROPOSED ALGORITHM FOR WIU UNITS OF CAN NETWORKS

Fig 3 and 4 shows two CAN networks, communication between these two networks is in two ways. First is CAN to CAN communication and other is CAN to Wi-Fi and Wi-Fi to CAN communication. Below shown algorithm are proposed communication scheme between these two networks. These two networks are having four nodes as shown in fig 3 and 4. Algorithm for node 1 and 3 shown in figure 6 (a & b) and for node 2 and 4 shown in figure 7 (a, b, c, d, & e)

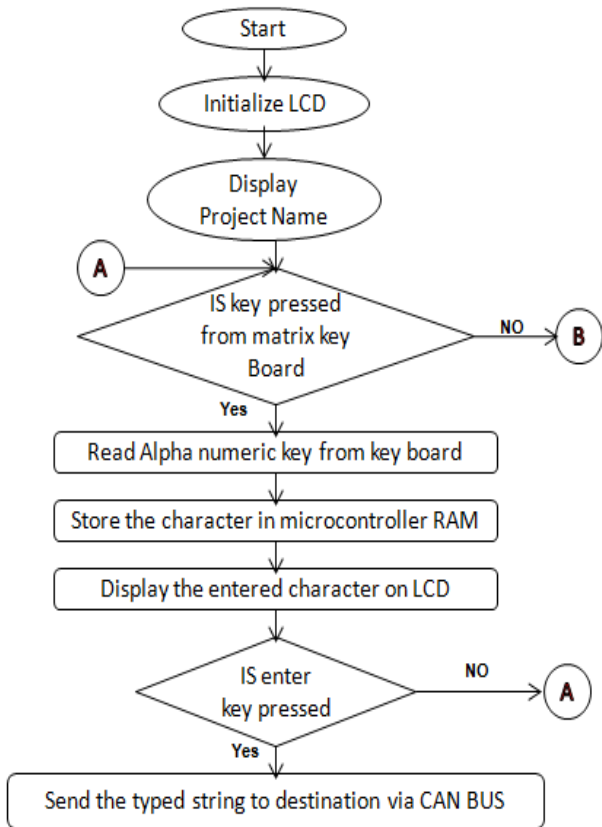

Fig. 6(a) algorithm for node 1 or 3

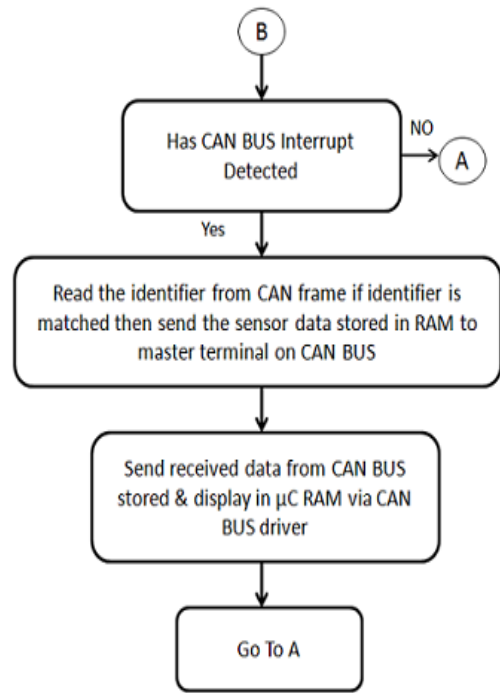

Fig. 6(b) algorithm for node 1 or 3

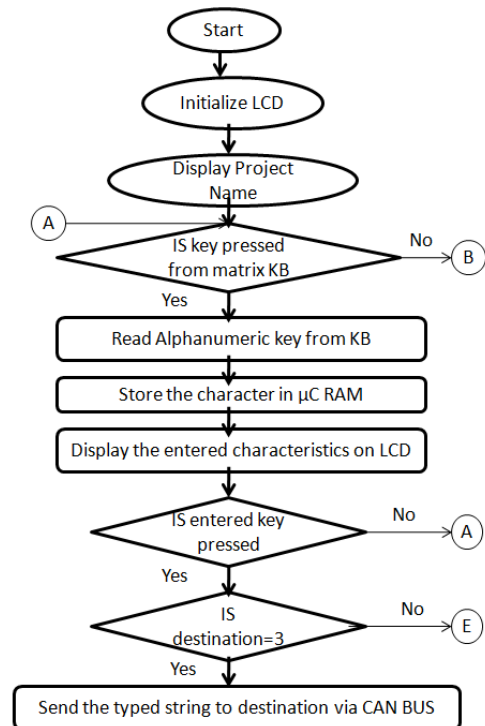

Fig. 7(a) algorithm for node 2 or 4

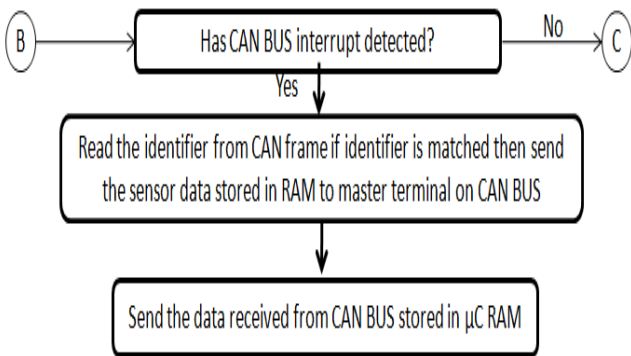

Fig. 7(b) algorithm for node 2 or 4

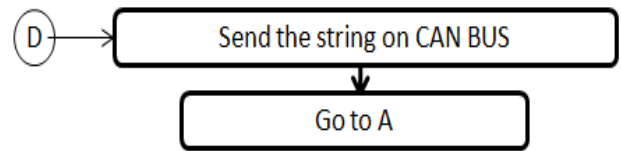

Fig. 7(d) algorithm for node 2 or 4

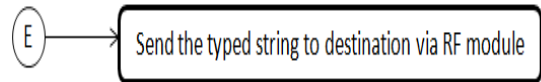

Fig. 7(e) algorithm for node 2 or 4

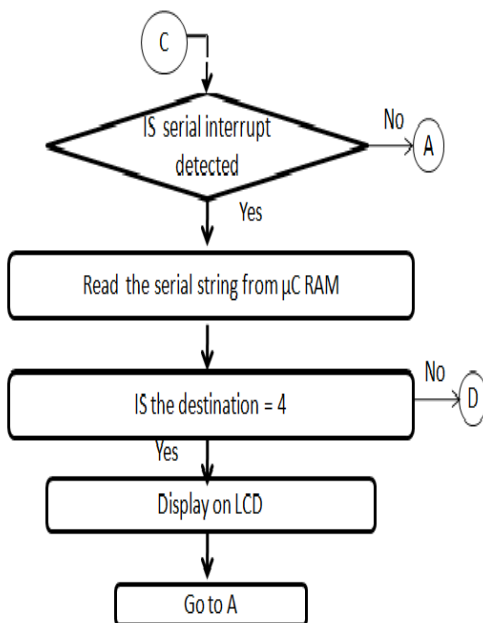

Fig. 7(c) algorithm for node 2 or 4

### V. CONCLUSION

The aim of this work presented has been to propose design and implementation a sample CAN/WLAN/CAN interworking system using Wireless Interworking Units (WIU). The WIUs employed provide a service to achieve the wireless interconnection of two CAN2.0B segments using an IEEE 802.11b WLAN. Considering their easy and widespread usage in many industrial areas, CAN nodes emerge inevitably to need this type of wireless internetworking for greater flexibility for their applications to be controlled remotely.

### REFERENCES

- [1] Erturk, "A new method for transferring CAN messages using wireless ATM", *Journal of Network and Computer Applications*, vol. 28, pp. 45-56, 2005.
- [2] C. Bayilmis, I. Erturk, and C. Ceken, "Wireless Interworking Independent CAN Segments", *Lecture Notes in Computer Science, LNCS 3280*, pp. 299-310, 2004.
- [3] C. Bayilmis, I. Erturk, and C. Ceken, "Extending CAN Segments with IEEE 802.11 WLAN", *The 3rd ACS/IEEE International Conference on Computer Systems and Applications, AICCSA-05, Egypt*, 2005.
- [4] H., Ekiz, A., Kutlu, E., T., Powner, "Design and Implementation of a CAN/Ethernet Bridge", *Proceedings of the ICC'96 3rd International CAN Conference, France*, pp. 1117-1126, 1996.
- [5] W., Lawrenz, "CAN System Engineering: from Theory to Practical Applications", Springer-Verlag, New York, pp. 1-289, 1997.
- [6] M., Farsi, K., Ratckiff, M., Babosa, "An Overview of Controller Area Network", *Computing and Control Engineering Journal* 10 (3), pp. 113-120, 1999.

- [7] Part 11: Wireless LAN Medium Access Control (MAC) and Physical Layer (PHY) Specifications, IEEE Standards 802.11, pp. 195–200, 1999.
- [8] L. A. C. Castelluccia, “Priorities in WLANs”, *Computer Networks*, Vol. 41, pp. 505–526, 2003.