

BASED ON INFINEON TC277 MICROCONTROLLER (POWER TRAIN) FOR THE VERIFICATION OF COMPLEX DEVICE DRIVERS OF SIX CYLINDER ENGINE

Shakuntala Chouhan¹, Suchi Mishra², Sunil Jamra³, Nikhil Goyal⁴

^{1,2}Assistant Professor, S.A.T.I. Engineering College Vidisha (M.P.)

^{3,4}Lecturer, S.A.T.I. Polytechnic College Vidisha (M.P.)

Abstract- The objective is to develop a model of the internal combustion six cylinder engine in System C so that it can be integrated with the TC277 simulation model and run the engine control algorithm in simulation. To control the other parameters such as accelerator pedal position, air/fuel ratio etc., and to show the status parameters such as engine RPM etc. a graphical user interface (GUI) also will be developed.

Index Terms- ECU-Engine control unit, HIL-Hardware-in-loop, ICE-Internal combustion engine, MAP-Manifold Air Pressure, VCCT-Variable Crank Cam Timing, IOM-Inlet Outlet Manifold.

I. INTRODUCTION

An Engine Control Unit (ECU) is an electronic circuitry which controls various aspects of an internal combustion engines operation also known as an Engine Control Module (ECM).. In the Automobile industry an electronic control unit (ECU) is an embedded electronic device that read signals coming from sensors placed at various parts and in different components of the car and depending on this information controls various important units e.g. engine and automated operations within the car and also keeps a check on the performance of some key components used in the car. Starting from the simplest ECUs that control the quantity of fuel injected into each cylinder each engine cycle to the most modern ECUs control the ignition timing, Variable Crank Cam Timing (VCCT), the level of boost maintained by the turbocharger (in turbocharged cars), and control other peripherals, ECUs now become a necessary component in the system to achieve the current emission norms. ECU determines the

quantity of fuel, ignition timing and other parameters by monitoring the engine through sensors. These include MAP sensor, throttle position sensor, air temperature sensor, engine coolant temperature sensor and many others. Most of the early generation ECUs all engine parameters were fixed. The quantity of fuel per cylinder per engine cycle was determined by a Carburetor.

II. PROBLEM STATEMENT AND OBJECTIVE

The device drivers developed for fuel injection, ignition, crank etc. are normally tested using Hardware-in-loop (HIL) setups and they require enormous amount of investment and the configuring and debugging of HIL setups are time consuming. Infineon provides simulation for running the engine control software as it is run on the real silicon. However to verify the above mentioned device drivers, a model of the internal combustion engine is also required. The objective is to develop a model of the internal combustion engine in SystemC so that it can be integrated with the TC277 simulation model and run the engine control algorithm in simulation. To control the other parameters such as accelerator pedal position, purity of the air etc., and to show the status parameters such as engine RPM etc. a graphical user interface (GUI) also will be developed.

III AUTOMOTIVE MICROCONTROLLERS

The automotive microcontrollers generally designed for automotive industries where these microcontrollers usually have more number of modules specially interface modules like I2C, SPI,

CAN, Flex Ray, UART, etc.. All these are referred as IPs (intellectual properties). These micro controllers can have multiple CPUs (Central Processing Unit)/cores operating independently with different modules. The safety module is the one which monitors all other internal modules and gives the signal to the CPU.

IV BASIC ECU OPERATIONS

(A) Control of fuel injection

For an engine with fuel injection, an ECU will determine the quantity of fuel to inject based on a number of parameters. If the throttle pedal is pressed down, the ECU will inject more fuel. If the engine has not warmed up yet, more fuel will be injected (causing the engine to run slightly 'rich' until the engine warms up).

(B) Control of Ignition Timing

A spark ignition engine requires a spark to initiate combustion in the combustion chamber. An ECU can adjust the exact timing of the spark (called ignition timing) to provide better power and economy. If the ECU detects knock, a condition which is potentially destructive to engines, it can delay (retard) the timing of the spark to prevent.

(C) Control of Air/Fuel ratio

For an engine with fuel injection, an engine control unit (ECU) will determine the quantity of fuel to inject based on a number of parameters. If the throttle position sensor is showing the throttle pedal is pressed further down, the mass flow sensor will measure the amount of additional air being sucked into the engine and the ECU will inject fixed quantity of fuel into the engine (most of the engine fuel inlet quantity is fixed). If the engine coolant temperature sensor is showing the engine has not warmed up yet, more fuel will be injected (causing the engine to run slightly 'rich' until the engine warms up). Mixture control on computer controlled carburetors works similarly but with a mixture control solenoid or stepper motor incorporated in the float bowl of the carburetor.

(D) Programmable ECUs

The current generations of ECUs are programmable on the field, i.e. these units do not have a fixed behavior, but can be reprogrammed by the

user. Programmable ECUs are required where significant aftermarket modifications have been made to a vehicle's engine. Examples include, adding or changing of turbocharger, adding or changing of intercooler, changing of exhaust system, conversion to run on alternative fuel. As a consequence of these changes, the old ECU may not provide appropriate control for the new configuration. In these situations, a programmable ECU can be wired in. These can be programmed or mapped while the engine is running by connecting a laptop to it using a serial or USB cable. This is achieved due to the very fact that the heart of the ECU is a microcontroller and the software can be reprogrammed any time to change the behavior of the ECU.

(E) DESIGN AND IMPLEMENTATION

(A) Methodology

1. Develop the Internal combustion engine model and the GUI using System C and Visual Studio respectively.
2. Test the model using a basic System C test bench.
3. Integrate the model into the TC277 system in Synopsys CoMET.
4. Use the drivers and develop basic applications to test the stable state of the internal combustion six cylinder engine.

V. DEVELOPMENT

To ease the testing of different components of the ECU or everything integrated together as ECU, simulations are heavily used. This mainly helps in reducing the cost, achieving more test coverage and improving the time to market. This method also helps in creating the scenarios that are very difficult to create in the real environment, even more; simulation models can be used for injecting faults in a controlled manner. Once the code containing the control algorithm is downloaded to the ECU we can test the performance of the ECU under extreme conditions, which

cannot be achieved in real world, by performing HIL simulation. Step includes develop the Internal combustion engine model and the GUI using SystemC and Visual Studio. Test the model using a basic SystemC test bench. Integrate the model

into the TC277 system in Synopsys CoMET. Use the drivers and develop basic applications to test the stable state of the internal combustion engine. Cost effective mechanism to design and develop the engine model to verify the complex device drivers Method can easily can provide the error tolerance and find the error easily. Automatic method of checking features and quality will reduce effort and time. As in Figure 3 the low level device drivers can be written based on the Infineon TC277 microcontroller for PWM generation and input capture/compare. PWM drivers are used to control the PWM Pulse which is usually control the PWM ignition, when ICE is in combustion state. The pulses on PWM wave indicate spark or ignition from the spark plug in combustion state. The efficiency of the engine is influenced by the timing of the trigger also. Just as in the case of ignition, the fuel injection also controlled by the

Microcontroller. ECU may control the amount of fuel to be injected into each cylinder. This varies depending on the engine's RPM and the position of the gas pedal (or the manifold air pressure). The engine tuner can adjust this by bringing up a spreadsheet- like page on the laptop where each cell represents an intersection between a specific RPM value and a gas pedal position (or the throttle position, as it is called). In this cell a number corresponding to the amount of fuel to be injected is entered. By modifying these values while monitoring the exhausts using a wide band lambda probe to see if the engine runs rich or lean, the tuner can find the optimal amount of fuel to inject to the engine at every different combination of RPM and throttle position. Process is often carried out at a dynamometer, giving the tuner a controlled environment to work in.

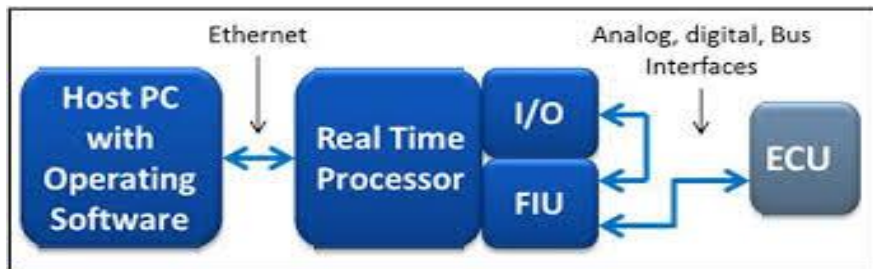

Fig. 1: ECU test setup integrates ICE simulation (HIL setup) for testing.



Fig. 2: ECU software test setup using simulation for testing software.

This method referenced in figure 1 and figure 2 also helps in creating the scenarios that are very difficult to create in the real environment,

even more; simulation models can be used for injecting faults in a controlled manner. Once the code containing the control algorithm is

downloaded to the ECU we can test the performance of the ECU under extreme conditions, which cannot be achieved in real world, by performing HIL simulation. Even one step further, Infineon provides simulation models of the microcontrollers such as TC277 that can be used to run the

software on it as it can be run on the real hardware. Some of the advantages are that the simulation models are available even before the chip itself is available and it can help tap the internal signals or inject faults. It is also cost effective compared to the HIL setup.

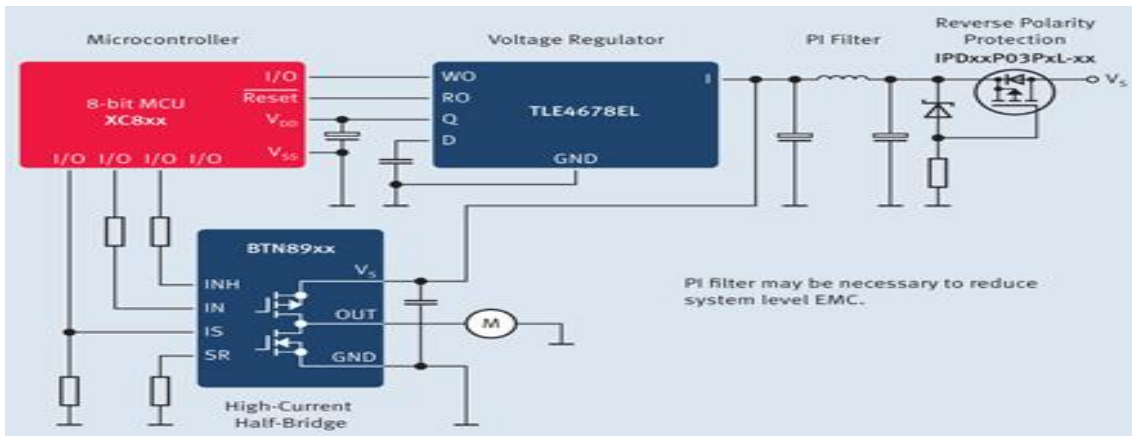

Fig. 3: Infineon TC277 microcontroller (power train application) used to develop the Internal combustion engine model

VI HARDWARE USED

- (A) Infineon Triboard and associated hardware
- (B) Bosch's Engine Control Unit- ME7-11

VII SOFTWARE USED

- (A) Visual Studio 2010 for the GUI, System C libraries for module development and module level testing.
- (B) Synopsys CoMET for integration of the model with the TC277 simulator and testing.
- (C) High-tech GNU Compiler Collection (GCC) for the compilation of the drivers.

VIII OUTPUT

- (A) Developed a graphical user interface (GUI) that provides controls for

parameters such as accelerator pedal position, air/fuel ratio etc., and shows the status parameters such as engine RPM etc. An ECU model was developed that interfaces with the TC277 virtual prototype.

- (B) Proposed work is to develop the SystemC testbench and test the model and GUI. Integrate the model into TC277 system in Synopsys Comet which will reduce effort and time. Using the driver and developing the basic applications to test the stable state of the internal combustion engine. Engine control software provides the difficulty in overcoming control and configurability, ease of injection of fault



Fig.4: Generated crank and cam signal during Engine Crank.

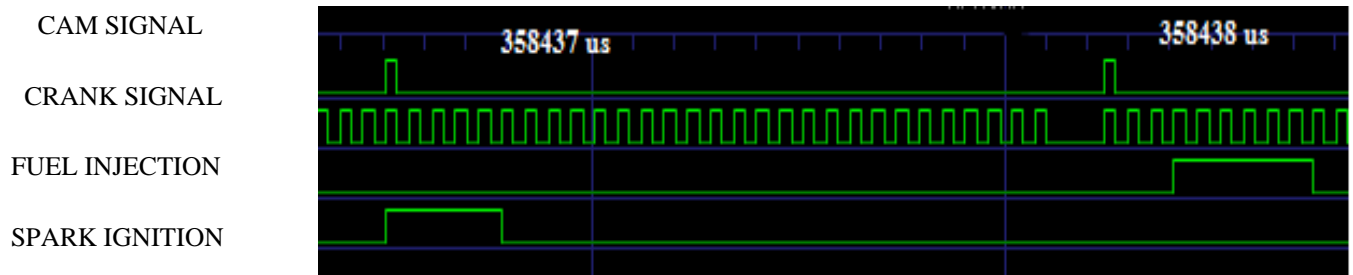

Fig.5: Fault injection fuel and spark signal

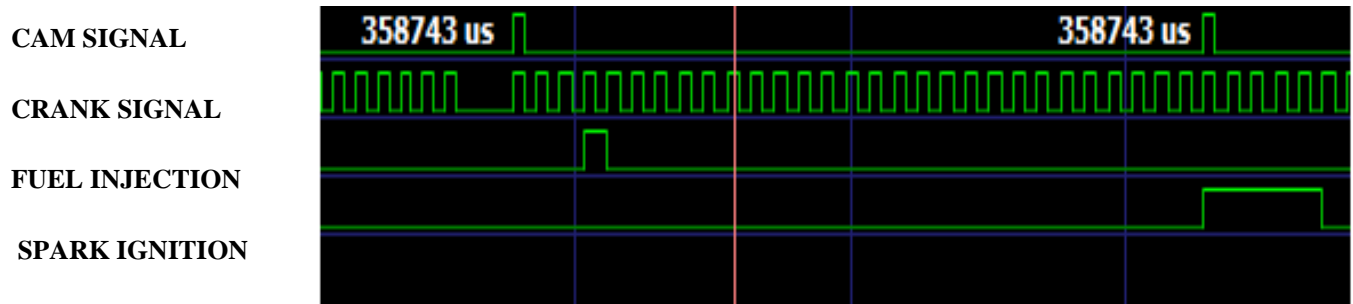

Fig.6: Fault injection of fuel and spark signal

IX RESULT

Developed engine model can verify the ECU drivers, without any configuration needed such as hardware setups. Debugging and tracing is easier compared to the HIL setup. Because HIL is often computationally complex and demanding than rapid control prototyping, due to the fact that high resolution is needed and high precision is necessary.

X CONCLUSION AND FUTURE ENHANCEMENT

Developed SystemC engine model to, verify complex device driver, configure error tolerance. In addition to these, this methodology also helps in debugging the driver easily. Enhance

the current methodology by varying the algorithms, which further reduces effort and time.

REFERENCES

- [1] D.J. Patterson and N.A. Henein, Emission from Combustion Engines and their Control, Ann Arbor
- [2] Science Publishers, Inc., 1972
- [3] J.I. Ramos, Internal Combustion Engine Modeling, Hemisphere Publishing Co., 1989.
- [4] J.B. Heywood and E. Sher, The Four-Stroke Cycle Engine: Its Development, Operation And design.
- [5] G.P. Blair, Design and Simulation of Four-Stroke Engines, SAE, 1996.