

# Implementation in Automatic Star Delta Starter with Protection Scheme

Mrunal Kolhe<sup>1</sup>, Ranjan Kumar<sup>2</sup>, Suraj Dhanvijay<sup>3</sup>, Prof C. J. Sharma<sup>4</sup>  
<sup>1,2,3</sup>BE Student, Department Of Electrical Engineering  
<sup>4</sup>Assistance Proffessor, Department Of Electrical Engineering  
 KDK College of Engineering, Nagpur, Maharashtra, India

**Abstract-** The project is designed to provide low voltage start to induction motor. This is achieved by using star to delta conversion. The star delta starter is generally obtained from three contractors, electromechanical timer and a thermal overload for operating a 3 phase motor at 440 volt at ac mains supply 50Hz. A set of relays are used to shift the motor connections from star to delta with a time delay. Since in star connection current is same in different phases while line voltage is root three times the phase voltage. So the voltage is reduced if motor is started as star. And also in delta connection the voltage is same as that of phase voltage so full voltage is applied if we run the motor as delta connection. The interlocking arrangement of all the contactor coils is traditionally wired in 440volt AC. If any of the phase goes off the single phasing circuit comes into action which disconnect the motor and save it from overloading.

**Index Terms-** Commutator, plugging, auxillary, stater, rectifier, torque.

## I. INTRODUCTION

An induction motor is similar to a poly-phase transformer whose secondary is short circuited. Thus, at normal supply voltage, like in transformers, the initial current taken by the primary is very large for a short while. (Unlike in DC motor, large current at starting is due to back emf) If an induction motor is directly switched on from supply, it takes 5 to 7 times its full load current, and develops a torque which is only 1.5 to 2.5 times the full load torque. This large starting current will produce large voltage drop in line, which may affect the operation of other devices connected in the line. From the torque equation of motor, it can be seen that starting torque can be improved by increasing the rotor resistance. Rotor resistance can be easily increased in case of slip-ring induction motor, but for squirrel cage motor current can be controlled by applying reduced stator voltage

Induction motors are popular due to their low-cost, sturdy construction, fast pick-up, low maintenance expenditure and good efficiency. The DOL (direct-on-line) starters and star/delta starters used for starting and running of induction

motors provide coarse type of protections against voltage fluctuations and single phasing. Induction motors are very sensitive to low voltage and single phasing during which they draw a heavy current and can burn out unless switched off within few seconds of occurrence of such conditions. This makes the requirement of a sensitive protective device essential to avoid burning of induction motors under such conditions. The circuit of an automatic starter, incorporating the important features given below, is described here. It is meant to be used in conjunction with a DOL starter. Automatic start on resumption of proper conditions Single phasing prevention 24-hour programmable off timer (on completion of actual runtime of the motor). An induction or asynchronous motor is a type of AC motor where power is supplied to the rotor by means of electromagnetic induction, rather than a commutator or slip rings as in other types of motor. These motors are widely used in industrial drives, particularly poly-phase induction motors, because they are rugged and have no brushes. Single-phase versions are used in small appliances. Their speed is determined by the frequency of the supply current, so they are most widely used in constant-speed applications, although variable speed versions, using variable frequency drives are becoming more common. The most common type is the squirrel cage motor.

Star/Delta starters are probably the most common reduced voltage starters in the 50Hz industrial motor world. Star delta is used in an attempt to reduce the start current applied to the motor then after sometime full load current is applied to the motor. Since in star connection current is same in different phases while line voltage is the root three times the phase voltage. So the voltage is reduced (results to reduce current) if motor is started as star and also in delta connection the voltage is same as that of phase voltage so full voltage is applied if we run the motor as delta connection. The Star/Delta starter is manufactured from three contactors, a timer and a thermal overload. The contactors are smaller than the single contactor used in a Direct on Line starter as they are controlling winding currents only. The currents through

the winding are  $1/\sqrt{3} = 0.58$  (58%) of the current in the line. this connection amounts to approximately 30% of the delta values. The starting current is reduced to one third of the direct starting current.

**Methods of starting induction motor are described below.**

Adding external resistance to the rotor of a squirrel cage motor is not possible. Starting in-rush current in squirrel cage motors is controlled by applying reduced voltage to the stator. For this purpose, following methods are used:

1. By using primary resistors or reactors
2. Autotransformer
3. Star-delta switches

## II. CONSTRUCTION AND CRICUIT COMPONENT OF STAR-DELTA STARTER

### a.) Wiring Diagram:

The main circuit breaker serves as the main power supply switch that supplies electricity to the power circuit. The main contactor connects the reference source voltage R, Y, B to the primary terminal of the motor U1, V1 and W1. In operation, the Main Contactor (KM3) and the Star Contactor (KM1) are closed initially, and then after a period of time, the star contactor is opened, and then the delta contactor (KM2) is closed.

The control of the contactors is by the timer (KIT) built into the starter. The Star and Delta are electrically interlocked and preferably mechanically interlocked as well. The star contactor serves to initially short the secondary terminal of the motor U2, V2 and W2 for the start sequence during the initial run of the motor from standstill. This provides one third of DOL current to the motor, thus reducing the high inrush current inherent with large capacity motors at startup.

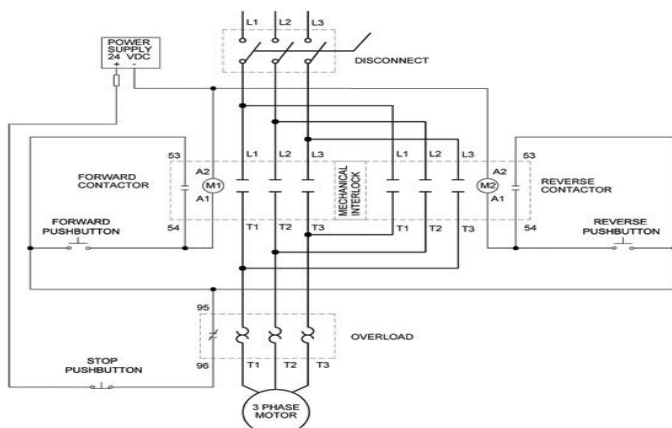

Controlling the interchanging star connection and delta

connection of an AC induction motor is achieved by means of a star delta or delta control circuit

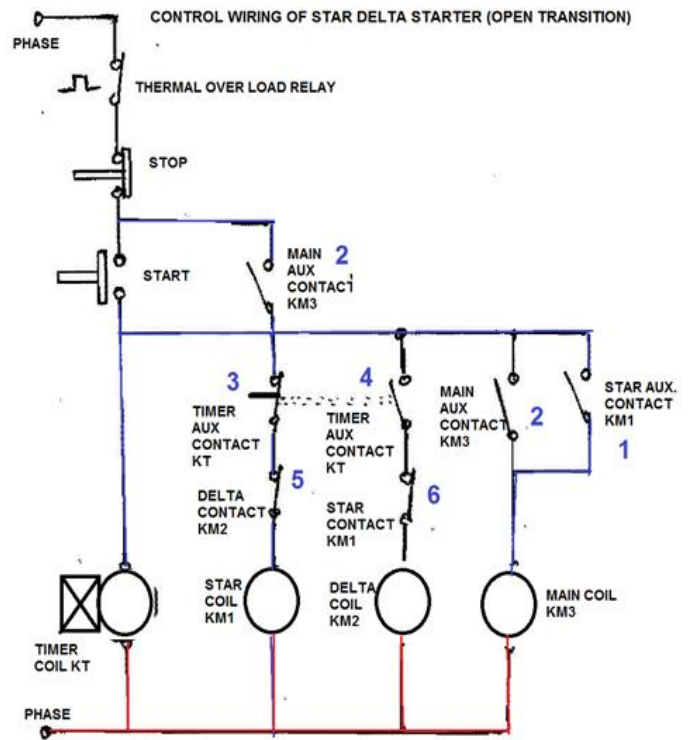

Fig. 1 Wiring Diagram of Star-Delta Starter

### b.) Control circuit

2.1 ON push button starts the circuit by initially energizing Star Contactor Coil (KM1) of star circuit and Timer Coil (KT) circuit.

2.2 When Star Contactor Coil (KM1) energized, Star Main and Auxiliary contactor change its position from NO to NC.

When Star Auxiliary Contactor (1) (which is placed on Main Contactor coil circuit) became NO to NC it's complete The Circuit of Main contactor Coil (KM3) so Main Contactor Coil energized and Main Contactor's Main and Auxiliary Contactor Change its Position from NO To NC. This sequence happens in a friction of time.

### Fig. 2 Control Circuit Diagram of Star-Delta Starter

After pushing the ON push button switch, the auxiliary contact of the main contactor coil (2) which is connected in parallel across the ON push button will become NO to NC, thereby providing a latch to hold the main contactor coil activated which eventually maintains the control circuit active even after releasing the ON push button switch. When Star Main Contactor (KM1) close its connect Motor connects on STAR and it's connected in STAR until Time Delay Auxiliary

contact KT (3) become NC to NO. Once the time delay is reached its specified Time, the timer's auxiliary contacts (KT)(3) in Star Coil circuit will change its position from NC to NO and at the Same Time Auxiliary contactor (KT) in Delta Coil Circuit(4) change its Position from NO To NC so Delta coil energized and Delta Main Contactor becomes NO To NC.

Now Motor terminal connection change from star to delta connection. A normally close auxiliary contact The from both star and delta contactors (5&6)are also placed opposite of both star and delta contactor coils, these interlock contacts serves as safety switches to prevent simultaneous activation of both star and delta contactor coils, so that one cannot be activated without the other deactivated first. Thus, the delta contactor coil cannot be active when the star contactor coil is active, and similarly, the star contactor coil cannot also be active while the delta contactor coil is active. The control circuit as shown in fig.3 above also provides two interrupting contacts to shut down the motor. The OFF push button switch break the control circuit and the motor when necessary. The thermal overload contact is a protective device which automatically opens the STOP Control circuit in case when motor overload current is detected by the thermal overload relay, this is to prevent burning of the motor in case of excessive load beyond the rated capacity of the motor is detected by the thermal overload relay. At some point during starting it is necessary to change from a star connected winding to a delta connected winding. Power and control circuits can be arranged to this in one of two ways – open transition or closed transition.

III. WORKING OF SINGLE PHASING PROTECTION

A three phase induction motor continuous to run even if one of the supply line is disconnected. The whole power is then supplied through the two windings and they are likely to get overheated. The single phasing causes unbalanced stator currents. The negative sequence component of unbalance current causes heating of rotor and temperature rise.

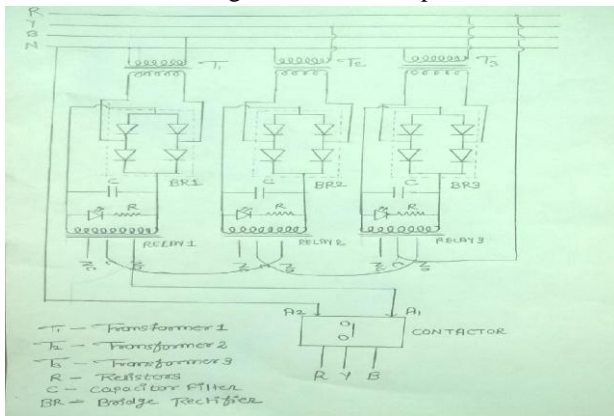

Such a condition can be caused by blowing of fuse in the supply circuit or due to improper contact in a switch or contactor. During single phasing, the current in healthy phases increases by root three times. This increases the heating in motor windings. This heating is not detected by thermal relay protecting the stator winding. Hence single phasing causes major damage to motor rotor, it cannot give instantaneous protection against single phasing.

For this protection three single phase transformer are used which are connected in each phase with neutral. After that bridge rectifier is used for converting ac into pure dc with the help of filters. After that for indication each of presence of each phase we use three LEDs in series with resistor .The three relays is used for the checking the continuity of supply. And then the main relay is connected to the terminals of the starter.

IV. SINGLE PHASING PROTECTION SCHEME

Supply is given to the three single phase transformer which step down the voltage at 12v (a.c.) than by using bridge rectifier this 12v a.c is converted into pulsating d.c .This pulsating d.c voltage is filtered by connecting filter circuit. Now three LEDs glow at the same time if the 3ph are present. Contacts of three relay are connected in series which is normally in closed position and common point for this three relays are connected to the main relay contacts.

If any one of the phase is disconnected from the supply

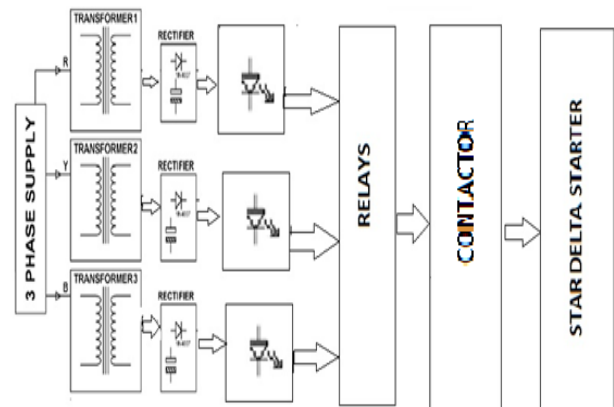

than the transformer is connected to that particular phase is disconnected from the supply. And the LEDs connected to with respective phase is off. Therefore all series connection of three relays are disconnected. And it will break the main relay and the circuit is off. After this the main relay is connected to the automatic star delta starter

In some application like elevator motors, where it is dangerous to eliminate plugging and reversing, the motor should be disconnected instantaneously when single phasing occurs

[5] Larabee, J.,Pellegrimo, B., Flick, B. "Induction motor starting methods and issues", Industry Applications Society 52 and Annual Petroleum and Chemical Industry Conference,2005,pp.217-222

Fig.3 Single Phasing Protection

#### V. ADVANTAGES AUTOMATIC SATR-DELTA STARTER

1. The operation of star delta method is simple and rugged.
2. It is relatively cheap compared to other reduced voltage methods.
3. Good torque/current performance.

#### VI. DISADVANTAGES AUTOMATIC SATR-DELTA STARTER

1. Low starting Torque
2. Break in Supply
3. It required 2 set of cables from starter to motor.

#### VII. CONCLUSION

We have presented an automatic star delta starter which is used for low to medium voltage and light starting motor. The automatic star delta starter employs a unique starting circuit to start an Induction motor automatically that cannot be observed in the traditional star delta starter. It is the cheapest method to reduce the starting current and it is in order of 3-4 times that in case of direct online starting of induction motor. It can be easily implemented by the relays and the timer circuit. Here we used relay which also prevents the motor from single phasing.

#### REFERENCES

- [1] G. C. Soukup "Cause and analysis of stator and rotor failures in three phase squirrel cage induction motors", IEEE Trans. Ind. Applicat, vol.28, no.4, pp.921-937 1992
- [2] AkshayRohilla,Harish Chand Joshi, AnuragNegi,"Star Delta Starter of Induction Motor",2014IJIRT,Volume 1Issue 6,ISSN:2349-6002.
- [3] Assfaq Hussain,"Electrical Machines",Second Edition,Publication Dhanpatrai and Co-oprative.
- [4] Sunil.S.Rao,"Switchgear Protection and power system", Khanna Publication.