

DESIGN AND ANALYSIS IN VENTILATED DISC BRAKE FOR TWO WHEELERS

N.Aravind Krishna¹, S.Manikandan², S.Praveen Kumar³, K.Yokeswara⁴

^{1,2,3}UG Scholar, Department of Automobile Engineering,

⁴Assistant Professor, Department of Automobile Engineering,

Dr. Mahalingam College of Engineering and Technology, Pollachi, Tamil Nadu, India-642003

Abstract—Disc brake is a device by means of which artificial frictional resistance is applied rotating disc, in order to stop the motion of vehicle. During the brake phase, the frictional heat generated at the interface of the disc and pads can lead to high temperatures. The frictional heat on the rotor surface can influence excessive temperature rise which in turn, leads to undesirable effects such as thermal elastic instability (TEI), premature wear, brake fluid vaporization (BFV) and thermally excited vibrations (TEV). In this project to decrease undesirable effects newly ventilated brake disc is designed for two wheelers. In this project 3 types holes are used in ventilated brake disc are; circle, square, hexagon. By using this ventilated brake disc, heat dissipation will be increased and increase in air flow in the brake disc.

I. INTRODUCTION

Disc brake is one of the types of brake which uses calipers to push the stationary pads to hold the rotating disc produce a friction. Friction slow down the rotation of disc which is attached to the wheel. Brakes converts the kinetic energy into the heat and too much of heat cause the ineffective braking known as brake fade.

A brake is a device by means of which artificial frictional resistance is applied to moving machine member, in order to stop the motion of a machine. In the process of performing this function, the brakes absorb either kinetic energy of the moving member or the potential energy given up by objects being lowered by hoists, elevators etc. The energy absorbed by brakes is dissipated in the form of heat. This heat is dissipated in to the surrounding atmosphere to stop the vehicle, so the brake system should have the following requirements:

1. The brakes must be strong enough to stop the vehicle with in a minimum Distance in an emergency.
2. The driver must have proper control over the vehicle during braking and the vehicle must not skid.
3. The brakes must have good ant fade characteristics i.e. their effectiveness should not decrease with constant prolonged application.
4. The brakes should have good anti wear properties.

Here various analyses are done in thermal like temperature analysis and heat flux. Heat flux is taking for, thermal loading is characterized by the heat flux entering the disc through the real contact area (two sides of the disc) [1]. Fatigue and stress is another part of this ventilated disc brake analysis.

II. MODELING AND ANALYSIS

MATERIAL SELECTION:

Tab 3.1 Material Properties of Grey Cast Iron

PROPERTIES	VALUES
Density (g/cm ³)	7.2
Melting point (°C)	1200-1300
Elastic modulus (GPa) (Tension)	125
Thermal conductivity (W/m K)	42.0-62.0
Specific heat J/(kg K)	460
Coefficient of thermal expansion (×10 ⁻⁶ °C)	8.1-19.3(20°C)
Yield Strength	2.75742e+0.008 N/m ²

MODELING:

The modeling of the disc profile is done using solidworks. The conventional ventilated disc is of circle profile have been modeled

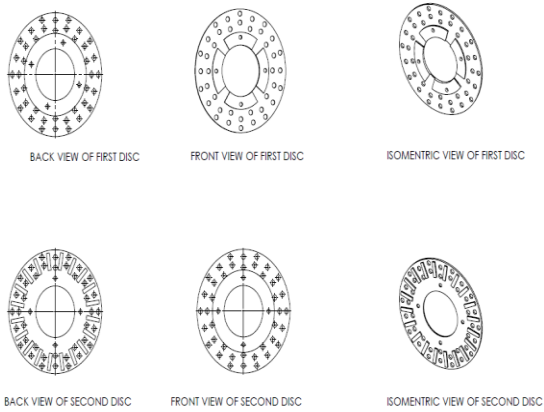

Figure 1 Modeling of new designed brake disc

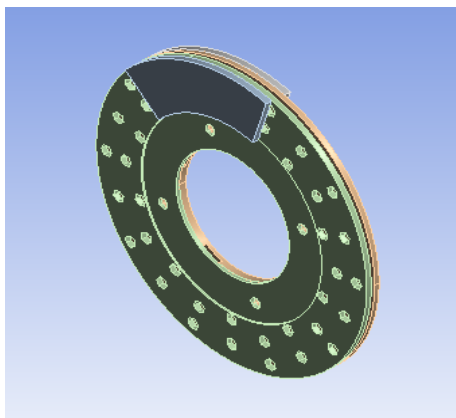

Figure 2 Isometric view of brake disc

THERMAL ANALYSIS:

The analysis is done using Ansys workbench module. The various profile of same area yield same deformation in the disc. The model is taken into steady state thermal analysis.

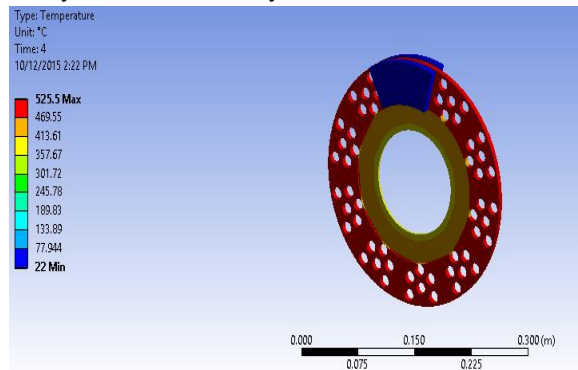

Figure 3 Temperature analysis of normal disc

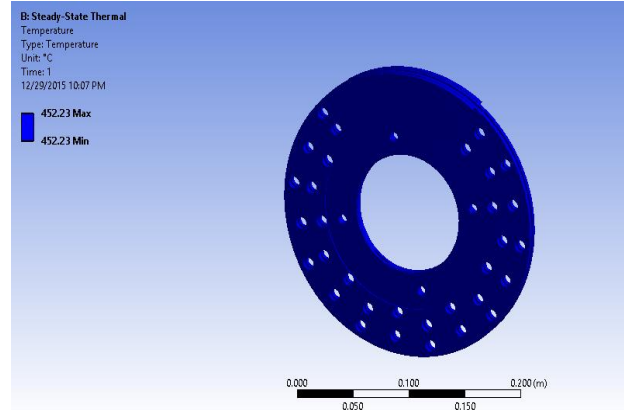

Figure 4 Temperature analysis of New designed disc

FATIGUE ANALYSIS:

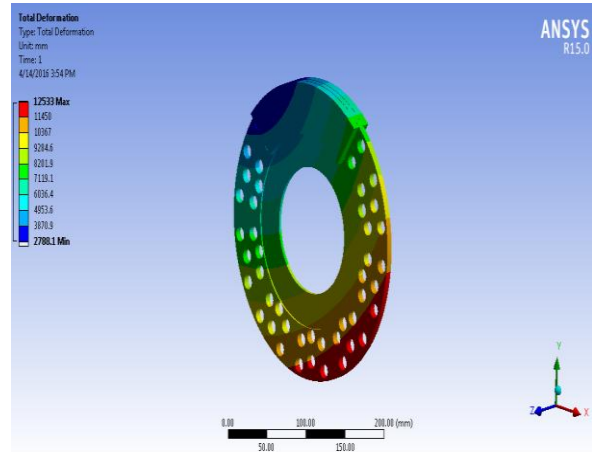

Figure 5 Deformation of normal disc

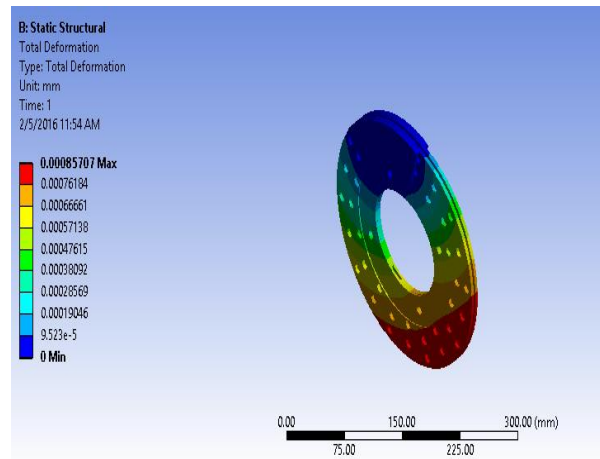

Figure 6 Deformation of new designed disc

2.5. STRESS ANALYSIS:

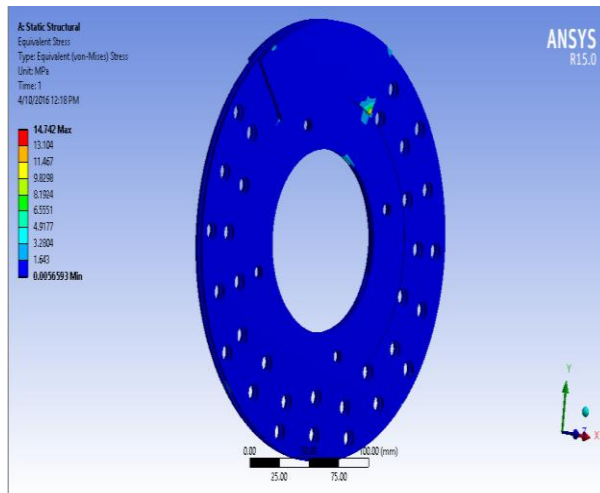

Figure 7 Stress analysis of normal disc

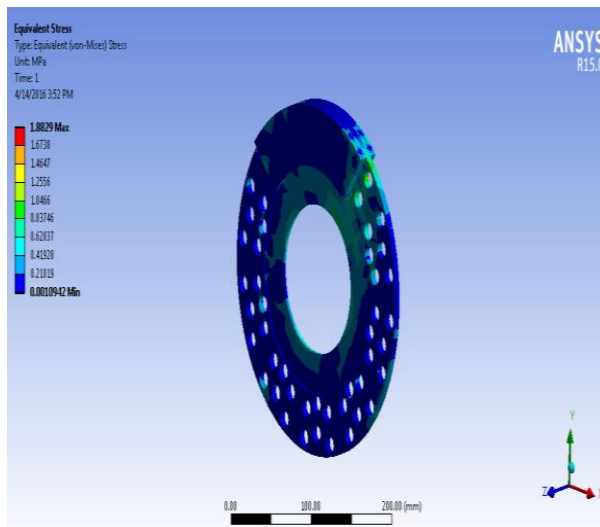

Figure 8 Stress analysis of new designed disc

III.RESULT AND DISSCUSION:

From the Thermal Analysis new designed brake disc is better while comparing to existing model. In this analysis heat dissipation is good comparing to existing model. From the Fatigue analysis like damage, life and safety factor are same for new designed brake disc and existing model. In Stress analysis is good in new designed brake disc comparing to existing model while in minimum stress. While in maximum existing model in better, but new designed brake disc did not reach maximum stress.

IV. CONCLUSION

A modified brake disc design was undergone a various analysis in ANSYS. In this analysis modified new design brake disc results were shows improvement compare to existing model. Heat dissipation is high in new designed brake disc when comparing normal brake disc is good. According to new designed brake disc has shown a good result in heat dissipation, Stress analysis and fatigue analysis, safety factor producing is equal to normal brake disc. So concluding that Ventilated Designed Brake Disc can be applicable for two wheeler brake system.

ACKNOWLEDGMENT

We express our hearty thanks to our Guide, **Mr.K.Yokeswaran M.E**, Assistant Professor, Department of Automobile Engineering for providing us kind advice his constant support and guidance offered to us during the course of our project by being one among us.

REFERENCE

- [1] Ali Belhocine, Mostefa Bouchetara” Simulation of fully coupled thermomechanical analysis “ 2013.
- [2] M.Nouby, K.Srinivasan,”Disc Brake Squeal Reduction through Pad Structural Modifications”, 2009.
- [3] Piotr Grzes, “Finite Element Analysis of DiscTemperature during Braking Process”.
- [4] Swapnil R. Abhang, D.P.Bhaskar,”Design and Analysis of Disc Brake”, 2014.
- [5] Gnanesh, Naresh and Syed Altaf Hussain, “Finite Element Analysis of Normal and Vented Disc Brake Rotor”,2014.