

Structural and Vibrational Analysis of Six axis ARISTO robot using ANSYS

Mr. P. G. Chitte¹, Mr. S. S. Bansode², Mr. S. S. Rathod³, Mr. N. S. Motgi⁴
^{1,2,3}Asst.Prof., Walchand Institute of Technology, Solapur
⁴Asst.Prof., Dypiemr, Akurdi, Pune

Abstract- Six axis ARISTO robot is a main component of FMS Setup and it is crucial part of automation industries. This paper deals with static and vibrational analysis with the help of ANSYS software so as to decide which material we should use and how much load robot will bear.

Index Terms- ARISTO robot, arm, static and vibrational analysis.

I. INTRODUCTION

1.1 FMS (Flexible Manufacturing Systems):-

A Flexible Manufacturing System (FMS) is a production system consisting of a set of identical and/or complementary numerically controlled machine which are connected through an automated transportation system. Each process in FMS is controlled by a dedicated computer (FMS cell computer).

A flexible manufacturing system (FMS) is an arrangement of machines ... interconnected by a transport system. The transporter carries work to the machines on pallets or other interface units so that work-machine registration is accurate, rapid and automatic. A central computer controls both machines and transport system.

“FMS consists of a group of processing work stations interconnected by means of an automated material handling and storage system and controlled by integrated computer control system.”



Fig 1.1 FMS Set-Up

1.1.1 Robot:-

Robot is a machine that collects the information about the environment using some sensors and makes a decision automatically. People prefers it to use different field, such as industry, some dangerous jobs including radioactive effects. In this point, robots are regarded as a server. They can be managed easily and provides many advantages.

A robot arm is known manipulator. It is composed of a set of joints separated in space by the arm links. The joints are where the motion in the arm occurs. In basic, a robot arm Consists of the parts: base, joints, links, and a gripper. The base is the basic part over the arm, it may be fix or active. The joint is flexible and joins two separated links. The link is fix and supports the gripper. The last part is a gripper. The gripper is used to hold.

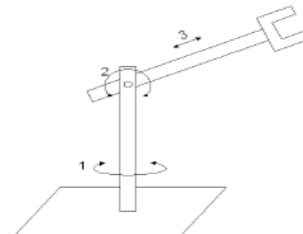

Fig.1.2 Basic robot arm. 1. Base, 2. Joint, 3. Link and the last part, gripper.

The static analysis is calculates the effects of steady loading conditions on a structure & calculate the effect of damping in the various load condition on any point of robot body.

Vibration analysis is the analysis of different vibration acting on the robot body when the parts or links are in the moving condition after loading. Vibration is the physical movement or oscillation of a mechanical part about a reference position.

The Static analysis is not difficult to analyses. It is solved by analytical method. On the

other hand, the vibration analysis is hard to analyses using Ansys software and it will be harder with increase in degree of freedom.

1.1.2 Six Axis Aristo Robot:-

ARISTO is six axis articulated robotic arm of industrial for training and research and is manufactured to industrial standards. The robot is capable of lifting up to 2.5kg of pay load. The robot can be used with pneumatic or electrical grippers.

ARISTO has simulation software that allows the user to learn robot functions, application & programming.

ARISTO can be integrated in to an FMS or CIM set up of controlled via FMS or CIM software

Aristo robot is the pick and place type six axis robot.

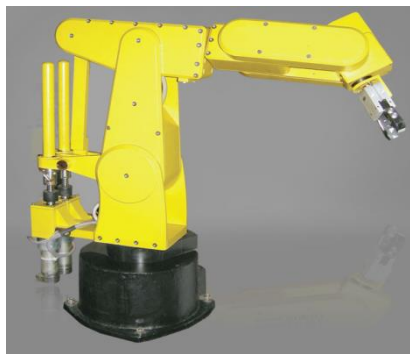

Fig 1.3 Six Axis Aristo Robot

1.1.3 Importance of the Project Area:-

The evolution of the performance of robots and programming software provides new machining solutions. For complex parts, six axes robots offer more accessibility than a machining center CNC 5 axis and allow the integration of additional axes to extend the workspace. Robots have seen in recent years an expansion of their field of use with new requirements related to the increasing use of composites. The robots are then considered for machining operations (polishing, cutting, drilling etc.) that require high performance in terms of position, orientation, followed by trajectory precision and stiffness. For drilling operations, the performance of position and orientation of the Tool Center Point are high priority. During the off-line programming of robots machinists, many factors are degrading the accuracy of the machining operation performed. As part of the proposed study, we focus on dynamical phenomena associated with the power. The objective of this work is to characterize the dynamical behavior of the robot to point out the influence of the task position in the robot workspace

concerning the dynamical response of the structure. This analysis is done in three stages: the first step is determining the self-excited frequencies of the robot structure in different configurations of work. The second step aims to analyze the dynamical vibration of the robot structure. During this step, the robot moves along with vertical axis but without holding the object in orders to highlight the impact frequencies in the dynamic case. In the last step, measurement and analysis of the robot structure vibration are conducted during the robot holder hold object and move.

1.1.4 Problem Identification:-

We visited our FMS laboratory in the college and saw the FMS setting very carefully. In that FMS set-up there was a six axis Aristo robot working well but there were many vibrations acting on the robot body. So we decided to do the analysis on this robot by using ANSYS software to calibrate the causes of vibration in the robot by this we identified the problem in this project.

1.1.5 Objectives of the work:-

The following are the objectives of the work:

1. Learn and control an articulated robot for broad application or special purpose application through robot control function and programming.
2. To identify the static and vibrational analysis of the six axis robot
3. To learn the software like Solidworks, Catia, Ansys etc.

II. LITERATURE REVIEW

2.1 Introduction:-

C. Devol (U.S. Patent 2988237 and J. Engelberger [1] state that an industrial robot is officially defined ISO [1] as an automatically controlled, reprogrammable, multipurpose manipulator programmable in three or more axes. The modern concept of industrial robotic manipulators was only introduced in late **1950s** by **G. C. Devol (U.S. Patent 2988237)** and later joined by **J. Engelberger** to start up Unimation Inc. They are the originators of the first industrial robot by Unimation Inc. in the 1959. The first installation of the Unimate robot for loading/unloading a die-casting machine at GM was in 1961 [2].

Early industrial robots were developed to perform operations in hostile environments such as inside radioactive chambers. Later, robots were applied to perform work in undesirable environments and in applications which were dull and monotonous. Today industrial robots can be found in

almost all manufacturing applications, ranging from machine servicing to welding to painting. Usage of robots for pick and place applications is the fastest growing segment of robotic. This is where the robot picks up an item, perhaps changes its orientation and puts it back, or moves it to another location and releases it there.

There are many types of industrial robots that are being used in industries nowadays. A simple example is an industrial robot manipulator with six degrees of freedom. It has the features of a human chest, upper arm, forearm and wrists respectively [3]. Therefore, it can be said that robots are designed to emulate human hand. The only difference is that it is much bigger compared to human hand.

A similar machine is used for winding of the electric wire for electric motors. Here wire is wound on the plate and it is taken out. Here the number of rotations is counted manually which is deciding the length of the wire. The machine is specially designed for the winding purpose only.

Rishu Sharma (Asth Professor, Maharaja Agrasen Institute of Technology Delhi, India) and **Piu Jain** (Asth Professor, Maharaja Agrasen Institute of Technology Delhi, India) and **Garima Sharma** (Asth Professor, Maharaja Agrasen Institute of Technology Delhi, India) state about Flexible Manufacturing Process [2]

III. GEOMETRICAL 3D MODELING OF SIX AXIS ARISTO ROBOT WITH HELP OF SOLID WORKS SOFTWARE:

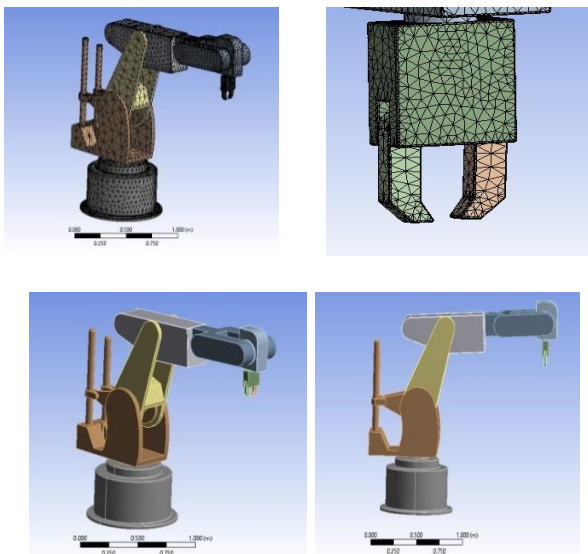

IV. STRUCTURAL ANALYSIS OF SIX AXIS ARISTO ROBOT

Material: Aluminum

(A) **Structural analysis results in below conditions (10kg):-**

1. **Equivalent (von-Mises) Stress :-**

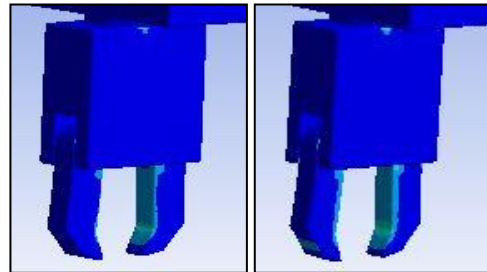

Fig. 4.1 Equivalent stress conditions of gripper

Minimum	1.8741e-009 Pa
Maximum	1585.2 Pa
Minimum Occurs On	Part 8
Maximum Occurs On	Part 1

Table 4.1 Results of Equivalent stresses

(B) **Structural analysis results in below conditions (10kg):-**

Material: Structural Steel

1. **Equivalent (von-Mises) Stress:-**

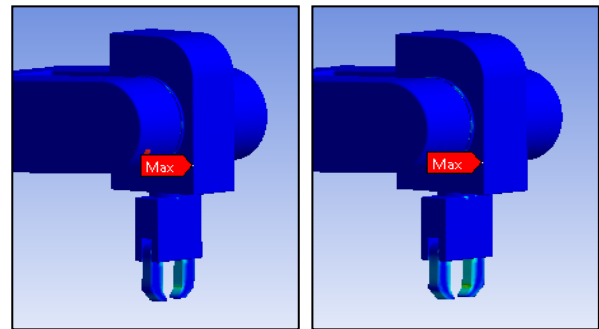

Fig. 4.2 Equivalent stress conditions of gripper

V. VIBRATIONAL ANALYSIS (NODAL)

Six Axis Aristo Robot

A) Vibrational (Nodal) analysis results in below conditions (Freq. 0-200Hz) :-

Material: Aluminum

1. Directional Deformation:-

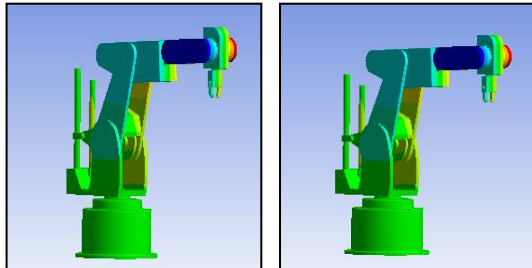

Fig.5.1 Directional Deformation conditions

Table 5.1 Results of Directional Deformation

Minimum	-0.28375 mm
Maximum	0.24427 mm
Minimum Occurs On	Part 5
Maximum Occurs On	Part 5

2. Effects on Robot While the Frequency Range increases:-

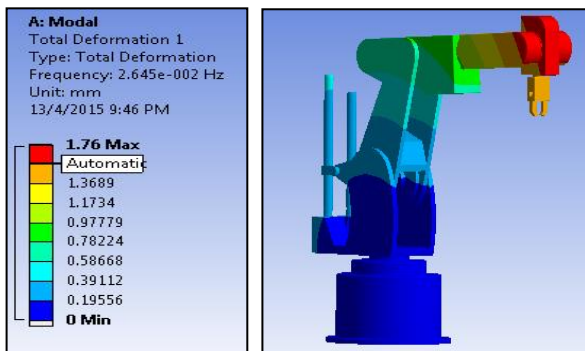

Fig. 5.2 Effects on Robot While the Frequency Range increases (1)

Table 5.2 Results of different frequency ranges (1)

Frequency level	Frequency (2.645e-002)	Frequency (5.6529e-002)
Minimum	0. mm	
Maximum	1.76 mm	2.6112 mm
Minimum Occurs On	Part 9	
Maximum Occurs On	Part 2	Part 8

B) Vibrational (Nodal) analysis results in below conditions (Freq. 0-200Hz):-

Material: Structural steel

1. Directional Deformation:-

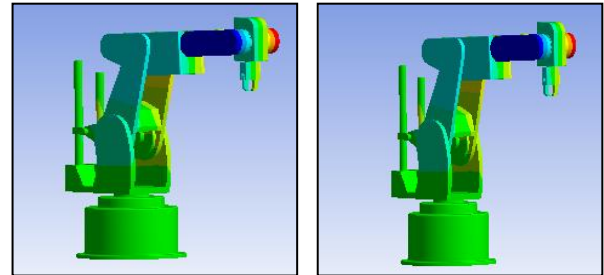

Fig. 5.3. Directional Deformation condition

Minimum	1.3047e-011 mm/mm
Maximum	1.1511e-003 mm/mm
Minimum Occurs On	Part 9
Maximum Occurs On	Part 4

Table 5.3 Results of Directional Deformation

2. Effects on Robot While the Frequency Range increases

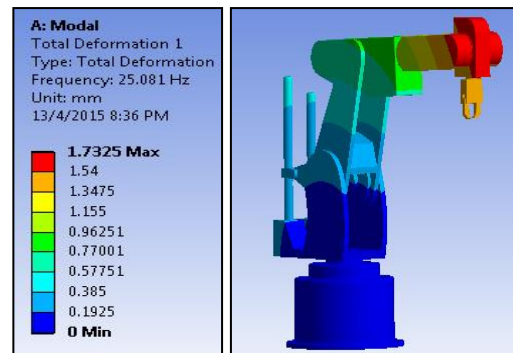

Fig. 5.4 Effects on Robot While the Frequency Range increases

Table 5.4 Results of different frequency ranges

Frequency level	Frequency (25.081)	Frequency (54.285)
Minimum	0. mm	
Maximum	1.7325 mm	2.5523 mm
Minimum Occurs On	Part 9	
Maximum Occurs On	Part 2	Part 8

VI. CONCLUSIONS AND FUTURE SCOPE

6.1 Conclusion:-

1. When we are applying the weight of (10kg) then this load is capable for the jaw of gripper and maximum load occurs on the gripper jaw
2. When we applying the weight of 12 kg or more than that then the gripper fails to sustain that load and it will break so we got the extreme weight capabilities of the jaws.
 - More conclusions by vibrational analysis & structural analysis are as follows:-
1. The current research aimed to reduce the weight of the structure, minimizing its structural deformations on directions Ox, Oy, Oz in order to improve the stiffness, on the basis of calculus of the loading forces applied in a static study. The suggested variants may be chosen from better shape, weight, stiffens, static and dynamic behavior.
2. Therefore the paper provides a methodology of analysis on the criteria of stiffness and mass while the static analysis determines a solution for a part of the arm that has been detailed. An optimization of a part of the structure from these points of view was performed and we have established the first analysis leading the best results.
3. Research methodology was developed to validate the theoretical results obtained by numerical analysis, finite element method (both those related to static analysis), the frequency modes and the optimization.
4. We have to point out that the design elements of the structure should carefully avoid discontinuities, variations in thickness, sudden changes of direction, small diameter holes and especially sharp angles in order to avoid concentration of stresses.

An improvement of the static behavior of the elements of the structure led to finding a constructive solution from the point of view of optimum weight, shape and static stiffness with changes imposed by successive loads and choosing the best option. Design objective is to find the form that provides maximum stiffness for a given mass. Its structural shape optimization requires a considerable computing time, many trials, is very dependent on user

5. continuous or composite structures. Topological optimization to obtain optimum generalized form of a structure is one of the priority areas of implementing the new techniques. The goal is to find the best use of the material for a structure subjected to the action of a force or more forces distribution.
6. From this perspective the aim of the topological optimization for structure design elements is to achieve a maximum rigidity and to optimize the topology with the mass control criteria and interference between the different composite materials.
7. experience rather than solve a local problem and can only improve certain aspects of structural behavior.
8. Topological optimization is a technique to determine the spatial pattern of its structure or to establish optimum generalized form of

6.2 Future Scope:-

A number of questions remain open for future work and some of them are indicated below

- The dynamic model, including other factors like frictional forces, actuator dynamics and etc., which influence the formulation of the dynamic model can be designed and researched.
- This research work is an evidence for the possibility of implementing the numerical tool in the practical control system of the manipulators. Other numerical tools may be used in the same work.
- This research work may be extended to 'n' number degrees of freedom of the robot manipulators and the vibration factors in linear joint may also be considered in the future work.
- By pointing out a few such avenues for future work, this study, the researcher believes, has provided the needed impetus in the direction.

REFERENCES (BIBLIOGRAPHY)

- **C. Devol (U.S. Patent 2988237)**-The first installation of the Unimate robot for loading/unloading a die-casting machine. Page no. 1, Year - 1961
- **Rishu Sharma** (Asth Professor, Maharaja Agrasen Institute of Technology Delhi, India) and **Piu Jain** (Asth Professor, Maharaja Agrasen Institute of Technology Delhi, India) and **Garima Sharma** (Asth Professor, Maharaja Agrasen Institute of Technology

Delhi, India)-Flexible Manufacturing Process.

Page no. 12, Year - April 2013

- Tutorials of solidworks (Solidworks 2013) – help - tutorial
- Reference Book of Finite Element Method – Mike Fagan,
- Reference Book of Flexible Manufacturing System - MTLAB booklet, Hand book of FMS Nand K. Jha
- Reference Book of Robotics -
- Tutorials of Ansys software (2013)
- www.scinedirect.com used papers for the previous work & references
- Vibrational Analysis – Adams, Groover
- Reference book of SOLIDWORKS-Solidworks team