

Study on Modern Ration Distribution System Techniques

Aishwarya Lodha¹, Shital R. Shegokar²

¹Student at Poornima College of Engineering, Department of Electronics Instrumentation and Control

²Assistant Professor, Department of Electrical Engineering, PCE, Jaipur

Abstract— This paper is all about automation in the field of Ration Distribution in India. In the modern times many unlawful activities are taking place in the ration shops. Ration Distribution Shops were made to distribute essential commodities (which includes staple food grains, such as wheat, rice, sugar, and kerosene) to a large number of people who are in below poverty line but Now a day ration card is very important for every home and used for various field such as family members details, to get gas connection, it act as address proof for various purposes etc. It is done by the Public distribution system but yet faces a lot of problems like corruption, ration hijack, false ration delivery and etc. All these happen because every job in the ration shop involves manual work and there are no specific hi-tech technologies to automate the job. Our main objective here is to automate the process of the ration distribution. The old method involves customer to tell the person handling the ration shop, the amount of the commodity he/she needs and the type too. The person working then measures the commodity and gives it to the customer. In this paper we are going to discuss different types of automatic ration distribution system implemented for the automatic ration distribution. It is a new concept which takes into account the various social, economic and general aspects relating to technical as well as day to day disciplines.

Index Terms— RFID, GSM, Embedded System, Microcontroller, Solenoid Control Circuits, Motor, PDS, Mechanical Parts

I. INTRODUCTION

India's Public Distribution System (PDS) is the largest retail system in the world. The execution of PDS scheme in a country like India is not an easy task; India is capital of largest chain of Fair Price Shops (FPS). The PDS is being executed and maintained by food and public distribution (PD) ministry of Indian Government. Public distribution system provides a ration card issued under an order or authority of the State Government which provides various grains like, Wheat, Rice, kerosene etc. on a subsidized rate, thus the poor's can be benefited. Even after knowing that PDS plays an important role in food security bill of Indian Government, yet this PDS system is affected by corruption, ration hijack and etc.

In India every family is issued a Ration card by Government of India and the families are to receive concision in food grains as per the card. Quantities of different food like rice, sugar, kerosene etc. is fixed for every month per families depending upon their income and total number of persons in family.

The aim behind this paper is to organize and atomize the ration distribution system. In order to make it centralize and secure system for ration distribution. State Government issues distinctive ration cards like yellow ration card, saffron ration card, and white ration card depending on family annual income. The consumer material is supplied to ration card holders in the first week of every month by ration shopkeeper. The proposed system aids to control malpractices which are present in ration shop by replacing manual work with automatic system.

II. LITERATURE SURVEY

In present days most of the people having their ration card to buy the materials from the ration shops first needs to submit the ration card to the ration distributor. After verifying the information on the card the distributor gives the material according to requirement but as per the allotment by Government. They will put sign on ration card depending on the materials taken and will issue the materials through weighing system with the help of human but there are two drawbacks- firstly, weight of materials may be inaccurate due to human error and secondly, if any card holder do not buy the materials by the end of the month then shopkeeper buy to other and doing deception.



Fig. 1. Manual Ration Distribution at Ration Shops

The current public distribution system (PDS) involves corruptions and illegal activities of goods during manual ration distribution process. This is one of the widely controversial issue that gives the wrong information about utilization of material allotted for the card holder. Fig. 1. shows the existing public distribution system.

III. DRAWBACKS WITH THE OLD SYSTEM

As there are many ration shops and the customers coming to buy material from ration shops are normally believed to be below poverty line and illiterate. There are complaints related to the quality of the product, the quantity they receive is many a times less than the quantity demanded by them as the shopkeeper steal from it. Moreover, they end up paying more for the quantity they receive. Also the quantity which is added in the ration card is wrong. So they cannot buy more the next time they need. So there is a lot of cheating and fooling of the customers that takes place. 55% of the PDS food grains does not reach the intended people.

According to the environmental conditions and government rule the price of material varies and it is different for people according to the type of ration card. Many a times it is observed that the ration distributors do not disclose the rate chart with proper reference date decided by the govt. of India. Due to which consumer are forced to pay as per rate decided by the distributors.

IV. SUGGESTED SOLUTIONS

Automating the existing system is our primary solution to the various problems existing. The various things that we can do to automate this system are explained below. The quantity of

weight required by the customer can be asked by the shopkeeper to enter into the application running on the computer at the outlet by the customer itself. Once the quantity is entered, the employee can place a container on the weighing machine. Now instead of him doing manually taking the grains weight, the customer /shopkeeper can push the start button that would be provided on the user interface of the application. Once the start button is clicked, a small door-like opening in a container placed at a height, above the place where the container is put for collecting the required amount of grains, will be opened by a solenoid valve. The grains start getting collected in the container. The weight will keep increasing continuously. It can be displayed on the weighing apparatus itself and also on the application running on the computer. Just when the weight reaches the quantity that was entered by the customer, the solenoid valve which opened the door-like opening in the container of grains; it will close that opening, as the required quantity has been reached. This detail can be entered into the database maintained at that shop through the application, by adding various details about the customer in the different fields provided. Thus the main delusion involved in the fooling of customer where they receive fewer amounts than what they have asked for and end up paying more, false entries in the ration card like making false entries or double entries etc., are all dealt with in this implementation of the system.

V. METHODS AND ALGORITHMS

The existing conventional ration distribution system has two basic issues one is renewing the ration card every year and corruption by the distributors by doing malpractices like diverting food grains to open market to make profit. To overcome these problems we need to develop ration distribution system.

The basic fundamental elements of such system are RFID and GSM Technology. Global System for Mobile Communication (GSM) is a globally accepted standard for digital cellular communication and RFID reader continuously transmits a 125 kHz carrier signal using its antenna. Such systems can be implemented with the different processor such as system using ARM7, PLC and PIC microcontroller.

A. Automatic Ration Distribution using ARM 7

In this system LPC2148 (ARM 7) plays a vital role of actual processing unit. It takes input from power supply of 3.3V for its operation. It is versatile processor designed for mobile device and other lower electronics.

Disadvantages with ARM 7

1. Cost is high

2. Complex instruction set
3. Complicated to designs because of more no. of pins

B. Automatic Ration Distribution using PLC

A PLC (Programmable Logic Controller) is an industrial computer used to monitor inputs and outputs depending upon their decisions based on its program or logic (On/Off) its output to automate a machine or process but PLC based ration distribution system has some disadvantages-

1. Difficulty with changes or replacements
2. Difficulty in finding errors
3. Hold-up time is indefinite, usually long
4. Cost of PLC iss high

C. Automatic Ration Distribution using PIC Controller

In this system microcontroller plays the vital role. It is a RISC based architecture. It is of low cost and is used for real time application. Its size is smaller as compared to PLC and ARM 7.

Advantages of PIC microcontroller-

1. Supports upto 32 endpoints
2. High performance RISC CPU
3. Four timer modules
4. On-chip USB Transceiver with On-chip Voltage Regulator

D. Automatic Ration Distribution using RFID and GSM

System consists of microcontroller-LPC2148, RFID, GSM, motor driver, solenoid valve circuitry, LCD and keypad. The proposed system demonstrates distribution of solid as well as liquid consumer materials. RFID reader, ultrasonic sensor, load cell and keypad acts as inputs to system and LCD is used for displaying ration stock and related activities. The microcontroller outputs are used to drive motor and solenoid valve.

Algorithm of proposed system is:

1. Every consumer is provided with a RFID card which is registered by the Government authority.
2. At the time of ration distribution at ration shop, first password of consumer is verified.
3. User ID verified with the database provided by the Government authority which is stored in the microcontroller.
4. Once verification is successful, consumer is asked for a select type of material and quantity required through push buttons and keypad respectively.

5. Based on type of material chosen, the motor or solenoid valve is activated.
6. The load cell or level indicator is checked for proper quantity.
7. After collecting proper quantity material motor or solenoid is disabled.
8. GSM module will send the information in form of SMS to the user as well as PDS authority.
9. Current stock in the ration shop is displayed using LCD.

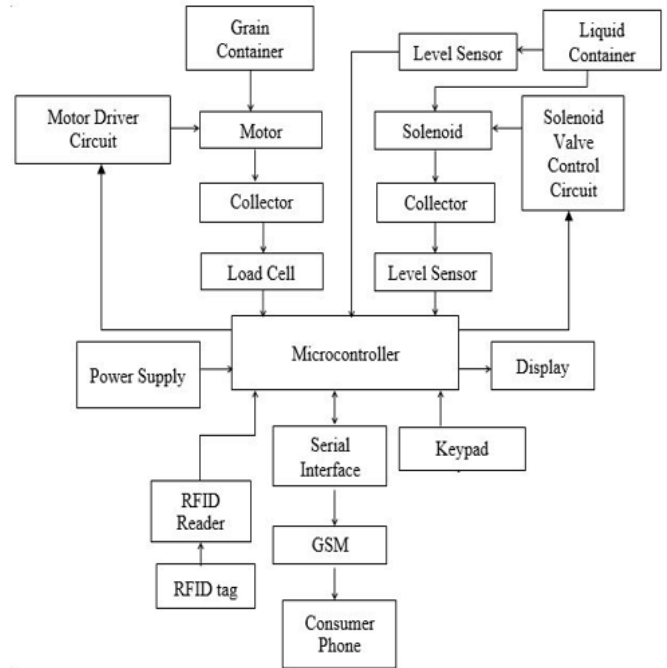

Fig. 2. System Block Diagram

VI. DESIGN AND IMPLEMENTATION

The diagram shown below represents the system architecture of the proposed system. It is a logical view of all the components that are required and how they will be connected. It shows the connection between various blocks of the projects set-up.

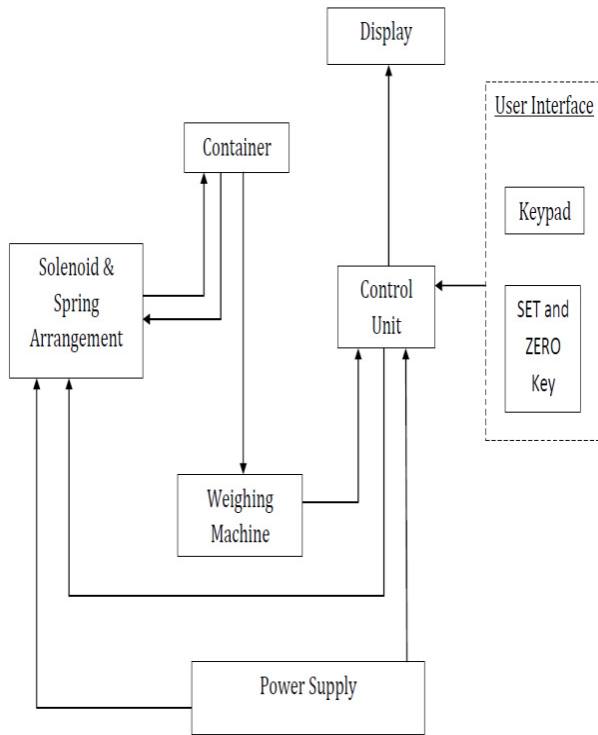

Fig. 3. System Design

The power supply is connected to the solenoid coil to activate it and it is given to the control unit. The control unit is connected to the keypad so that the user can enter the needed quantity of ration. The output of the control unit is given to the solenoid coil to activate and deactivate accordingly and the output is also given to the display to show the weight of the ration. The container is also connected to the weighing scale. The ration that flows out of the container falls on the weighing scale and is measured on it. The output of the weighing machine is given to the control unit to check whether the weight of the ration given to the customer and entered quantity is same or not. The container and the solenoid coil are connected together. When the solenoid coil is activated, it opens the flap of the container for the ration to flow out and when the coil is deactivated, the flap of the container is closed.

For implementing the above proposed automated solution, there are various hardware components that are required for making the setup. Also proper software is required for making the application which would work along with the hardware properly.

A) Hardware:

For the hardware part, the following components are required- A load cell which has the maximum weighing capacity according to the requirements, An ADC circuit, which can convert the analog signals that are received from the load cell and convert it to digital signals which can be used by microcontroller for further processing, A LCD display for displaying the weight which would be converted through the ADC by the microcontroller in digital format, A keypad which would be used for calibrating the load cell and the microcontroller so that the measurements are done properly, A power supply of +/- 5V and +12V and ground. The above components together make the entire one sub component, i.e. the weighing machine circuitry.

Another sub component is one for controlling the solenoid valve which opens and closes the opening of the container storing the commodity. It involves the following components- A microcontroller, a solenoid valve which pushes and pulls on giving a signal, a relay circuit. We will be using serial communication between the controller circuits and the computer. Thus RS232 serial port and IC MAX232 is required for connecting computer with weighing machine circuitry for receiving the weight that is calculated to be stored in the computer for comparison and computation purposes. The RS232 and IC MAX232 are also needed for communication between the microcontroller controlling the solenoid actuator and the computer. A signal from the computer will be passed so as to when open the container and when to close it. These are the various hardware components required for implementing the proposed solution.

B) Software:

For making the software of this project, we need to implement serial communication. Hence we need to select such software which provides such a feature. We can use Visual Basic 6 for this purpose. It provides us with a communication object MSCOMM which can be used for serial communication. By setting the various parameters like baud rate and other threshold values, we can send and receive data to and from the various controller circuits. It also provides us with data control feature to connect with various types of databases like MS ACCESS, SQL, etc. Thus VB6 is a good software choice to make a desktop application for the project.

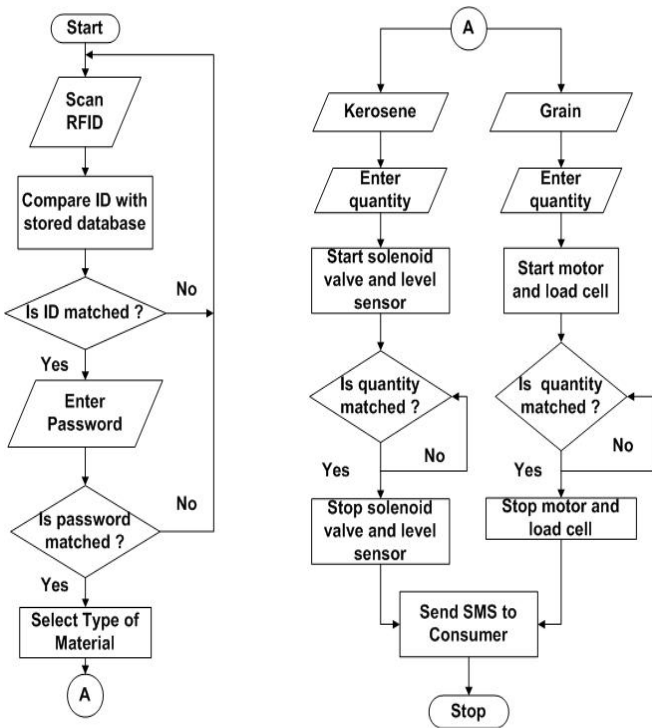

Fig. 4. Flow Chart of the system

VII. RESULT

Below we have shown the final block diagram of resulting system. The system is shown in two views- the front view and the side view through which we can understand and visualize the entire system about how it will actually look

FRONT VIEW

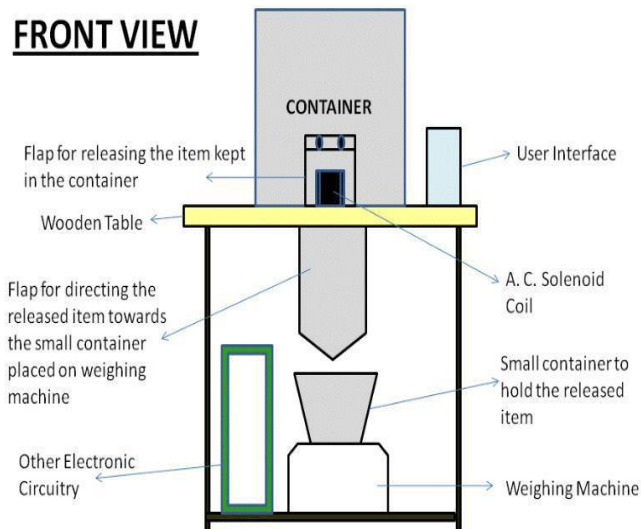

Fig. 5. Front View of the system

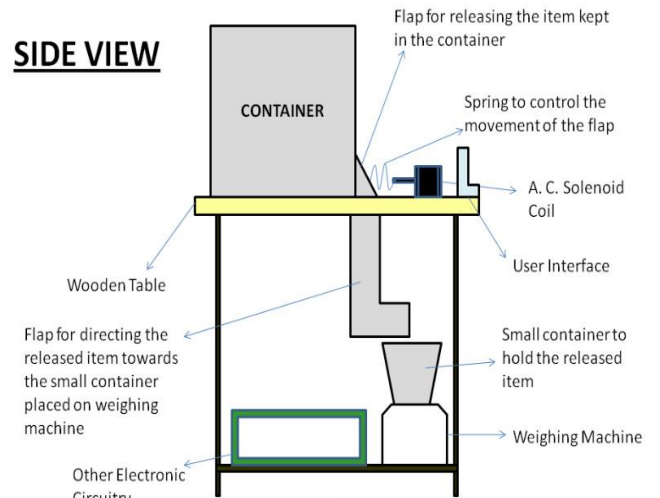

Fig. 6. Side View of the System



Fig. 6: Overall ration distribution system with mechanical parts

TABLE I

S.No.	Existing System	Proposed System
1	Ration Sheets Used	RFID tag act as a Ration Card
2	Ration Materials are distributed with the help of humans	Ration materials distributed automatically without the help of humans
3	Inaccurate	Accurate

Table 1. Comparative study of existing and proposed locker system

VIII. CONCLUSION

Existing manual ration distribution system leads to corruption. Distributors does not release the actual rate decided by government of India for the people below poverty line according to the card issued. Hence people are paying rate according to rate given by distributors not by the govt. and also the incorrect data of quantity availability. Through this paper, we have made intent to introduce a new technology which helps to remove the drawbacks of the existing system and also has its own advantages which are useful for other applications. It acts corruption to a great extent, which was one of the primary reasons we thought of while coming up with the idea.

REFERENCES

- [1] Jinali Goradia, Sarthak Doshi, "Automated Ration Distribution System," International Conference on Advanced Computing Technologies and Applications, USA (ICATA).
- [2] Swapnil R. Kurkute, Chetan Medhe, Ashlesha Revgade, Ashwini Kshirsagar, "Automatic Ration Distribution System-A Review", IEEE 2016.
- [3] S.Valarmathy, R.Ramani, "Automatic Ration Material Distributions Based on GSM and RFID Technology" International Journal Intelligent Systems and Applications, 2013, Vol. 11, pp. 47-54.
- [4] Vinayak T. Shelar, Mahadev S. Patil, " RFID and GSM based Automatic Rationing System using LPC2148" International Journal of Advanced Research I Computer Engineering and Technology (IJARCET).
- [5] Shubham Maheshwari, Mukesh Tiwari, M.Tech Student, Department of Electronics and Communication, SSSIST, Sehore, M. P, India "A Smart Public Ration Distribution System", International Journal of Innovative Research in Computer and Communication Engineering, Vol. 4, Issue 3, March 2016.
- [6] Prasanna Balaji.R1, Manikandan.T2, Automatic Public Distribution System, IJCSMC, Vol. 2, Issue. 7, July 2013, Pg.93 – 107.
- [7] Rajesh C. Pingle_And P. B. Boroley, Automatic Rationing For Public Distribution System (Pds) Using Rfid And Gsm Module To Prevent Irregularities, HCTL Open IJTIR, Volume 2, March 2013.
- [8] Gyanendra K Verma, Pawan Tripathi, "A Digital Security System with Door Lock System Using RFID Technology", International Journal of Computer Applications (IJCA) Volume5,11,August2010
- [9] Dhanoj Mohan, Rathikarani, Gopakumar, "Automation of Ration Shop Using PLC" International Journal of Modern Engineering Research, 2013, Vol. 3, Issue. 5.
- [10] S. Sukhumar, K. Gopinathan, "Automatic Rationing System Using Embedded System Technology" International Journal of Innovative Research in Electrical, Electronics, Instrumentation and Control Engineering, 2013, Vol. 1, Issue 8