

# Implementation of Novel Spray and Weeding Robot Using Mobile for Agriculture Field

Subramanian<sup>1</sup>, Dr.V .Mohan<sup>2</sup>, S.Sivamani<sup>3</sup>, S.Latha<sup>4</sup>

<sup>2</sup>Professor, Department of EEE, E.G.S.Pillay Engineering College, Nagapattinam, Tamilnadu, India

<sup>1,3,4</sup>Assistant Professor, Department of EEE, E.G.S.Pillay Engineering College, Nagapattinam, Tamilnadu, India

**Abstract-**A robot is an apparently human automation, intelligent and obedient but impersonal machine. It is relatively, that robots have started to employ a degree of Artificial Intelligence (AI) in their work and many robots required human operators, or precise guidance throughout their missions. Slowly, robots are becoming more and more autonomous. In our project a spray pump and Small Tank are combined with robotic mechanism. We can fill the compound of Chemical to the tank. The robotic mechanism will move forward or reverse depend upon Mobile key tone (DTMF) operation. Pump will pull the Chemical Compound from tank when we press the spray key. We are using matrix type keypad Mobile and each key operate different movement. LCD displayed for corresponding function or operation. This project is very useful for agriculture applications. Our aim of the project is to reduce the man power for agriculture field. How is to be possible means we give three or four level in program for the controller. Unwanted leaf removes with help of weeding mechanism. In this project, the robot is controlled by a mobile phone that makes a call to the mobile phone attached to the robot. In the course of a call, if any button is pressed, a tone corresponding to the button pressed is heard at the other end of the call. This tone is called 'dual-tone multiple-frequency' (DTMF) tone. The robot perceives this DTMF tone with the help of the phone stacked in the robot.

**Index Terms-** Spraying, Weeding, DTMF, Artificial Intelligence

## I. INTRODUCTION

The Robotics is the branch of mechanical engineering, electrical engineering and computer science that deals with the design, construction, operation, and application of robots, as well as computer systems for their control, sensory feedback, and information processing. These technologies deal with automated machines that can take the place of

humans in dangerous environments or manufacturing processes, or resemble humans in appearance, behavior and or cognition. Many of today's robots are inspired by nature contributing to the field of bio-inspired robotics. The concept of creating machines that can operate autonomously dates back to classical times, but research into the functionality and potential uses of robots did not grow substantially until the 20th century. Throughout history, it has been frequently assumed that robots will one day be able to mimic human behaviour and manage tasks in a human-like fashion. Today, robotics is a rapidly growing field, as technological advances continue; researching, designing, and building new robots serve various practical purposes, whether domestically, commercially, or militarily. Many robots are built to do jobs that are hazardous to people such as defusing bombs, finding survivors in unstable ruins, and exploring mines and shipwrecks.

## II. PROPOSED SYSTEM

The proposed system based on PIC microcontroller is found to be more compact, user friendly and less complex, which can readily be used in order to perform several tedious and repetitive tasks. Though it is designed keeping in mind about the need for industry, it can extended for other purposes such as commercial & research applications. Due to the probability of high technology (PIC microcontroller) used in this system is fully software controlled with less hardware circuit. The feature makes this system is the base for future systems. The principle of the development of science is that "nothing is impossible". So we shall look forward to a bright & sophisticated world.

III. DESIGN AND IMPLEMENTAION

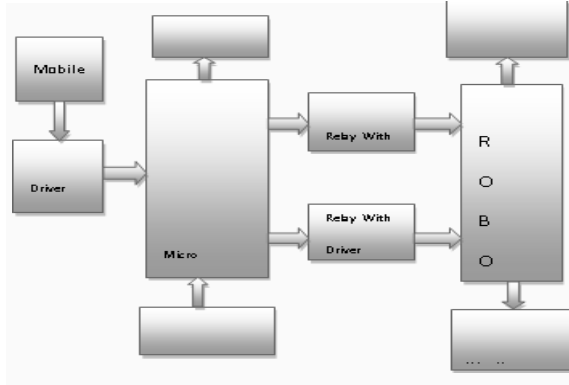

A. Transmitter Section



Fig.1 Block Representation

An electric motor uses electrical energy to produce mechanical energy. The reverse process, that of using mechanical energy to produce electrical energy, is accomplished by a generator or dynamo. Traction motors used on locomotives often perform both tasks if the locomotive is equipped with dynamic brakes. Electric motors are found in household appliances such as fans, refrigerators, washing machines, pool pumps, floor vacuums, and fan-forced ovens.

Most electric motors work by electromagnetism, but motors based on other electromechanical phenomena, such as electrostatic forces and the piezoelectric effect and thermal motors, also exist.

The fundamental principle upon which electromagnetic motors are based is that there is a mechanical force on any current-carrying wire contained within a magnetic field. The force is described by the Lorentz force law and is perpendicular to both the wire and the magnetic field. Most magnetic motors are rotary, but linear motors also exist. In a rotary motor, the rotating part (usually on the inside) is called the rotor, and the stationary part is called the stator. The rotor rotates because the wires and magnetic field are arranged so that a torque is developed about the rotor's axis. The motor contains electromagnets that are wound on a frame.

Though this frame is often called the armature, which term is often erroneously applied. Correctly, the armature is that part of the motor across which the input voltage is supplied. Depending upon the design of the machine, either the rotor or the stator can serve as the armature.



Fig.2 Electric Motor

Soil moisture sensors measure the water content in soil. A soil moisture probe is made up of multiple soil moisture sensors. This Soil Moisture Sensor can be used to detect the moisture of soil or judge if there is water around the sensor, let the plants in your garden reach out for human help. Insert this module into the soil and then adjust the on-board potentiometer to adjust the sensitivity. The sensor would outputs logic HIGH/LOW when the moisture is higher/lower than the threshold set by the potentiometer. Water monitoring

B. Features

- 1) Nickel plating to avoid corrosion
- 2) Working voltage: 3.3V-5V
- 3) On-board LM393 chip
- 4) Dimension of the board: 3.2cm \* 1.4cm



Fig.3 Soil Moisture Sensor

A relay is an electrically operated switch. Current flowing through the coil of the relay creates a magnetic field which attracts a lever and changes the switch contacts. The coil current can be on or off so

relays have two switch positions and they are double throw (changeover) switches. Relays allow one circuit to switch a second circuit which can be completely separate from the first. For example a low voltage battery circuit can use a relay to switch a 230V AC mains circuit. There is no electrical connection inside the relay between the two circuits; the link is magnetic and mechanical.

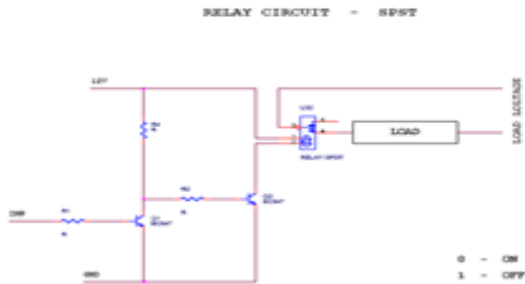

Fig.4 Relay Circuit

The coil of a relay passes a relatively large current, typically 30mA for a 12V relay, but it can be as much as 100mA for relays designed to operate from lower voltages. Most ICs (chips) cannot provide this current and a transistor is usually used to amplify the small IC current to the larger value required for the relay coil. The maximum output current for the popular 555 timer IC is 200mA so these devices can supply relay coils directly without amplification. Relays are usually SPDT or DPDT but they can have many more sets of switch contacts, for example relays with 4 sets of changeover contacts are readily available. Most relays are designed for PCB mounting but you can solder wires directly to the pins providing you take care to avoid melting the plastic case of the relay. The animated picture shows a working relay with its coil and switch contacts. You can see a lever on the left being attracted by magnetism when the coil is switched on. This lever moves the switch contacts.

The relay's switch connections are usually labeled COM, NC and NO:

- 1) COM = Common, always connect to this; it is the moving part of the switch.
- 2) NC = Normally Closed, COM is connected to this when the relay coil is off.
- 3) NO = Normally Open, COM is connected to this when the relay coil is on.

A relay is an electrically operated switch. Current flowing through the coil of the relay creates a magnetic field which attracts a lever and changes the

switch contacts. The coil current can be on or off so relays have two switch positions and they are double throw (changeover) switches. Relays allow one circuit to switch a second circuit which can be completely separate from the first. For example a low voltage battery circuit can use a relay to switch a 230V AC mains circuit. There is no electrical connection inside the relay between the two circuits; the link is magnetic and mechanical.

IV. HARDWARE DESIGN

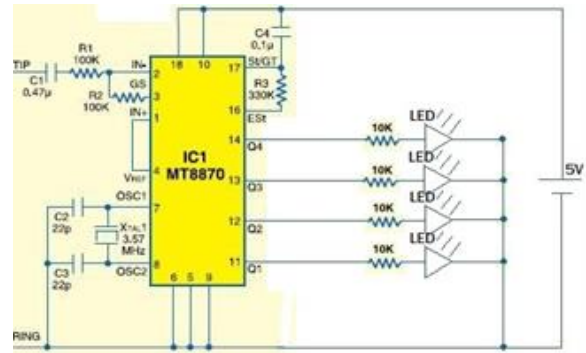

Fig.5 DTMF circuit

The received tone is processed by the ATmega16 microcontroller with the help of DTMF decoder MT8870. The decoder decodes the DTMF tone into its equivalent binary digit and this binary number is sent to the microcontroller. The microcontroller is preprogrammed to take a decision for any given input and outputs its decision to motor drivers in order to drive the motors for forward or backward motion or a turn. The mobile that makes a call to the mobile phone stacked in the Load acts as a remote. So this simple Load control project does not require the construction of receiver and transmitter units.

DTMF signaling is used for telephone signaling over the line in the voice- frequency band to the call switching center. The version of DTMF used for telephone tone dialing is known as 'Touch-Tone.' DTMF assigns a specific frequency (consisting of two separate tones) to each key so that it can easily be identified by the electronic circuit. The signal generated by the DTMF encoder is a direct algebraic summation, in real time, of the amplitudes of two sine (cosine) waves of different frequencies, i.e., pressing '5' will send a tone made by adding 1336 Hz and 770 Hz to the other end of the line. The tones and assignments in a DTMF system are shown in Table I.

An MT8870 series DTMF decoder is used here. All types of the MT8870 series use digital counting techniques to detect and decode all the 16 DTMF tone pairs into a 4-bit code output. The built-in dial tone rejection circuit eliminates the need for pre-filtering. When the input signal given at pin 2 (IN-) in single-ended input configuration is recognized to be effective, the correct 4-bit decode signal of the DTMF tone is transferred to Q1 (pin 11) through Q4 (pin 14) outputs.

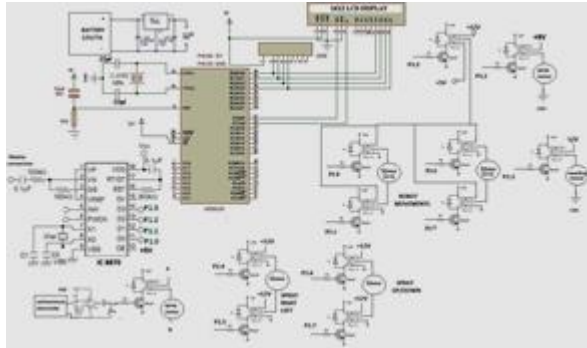

Fig.6 Circuit diagram

V. RESULTS AND DISCUSSIONS

When the key is pressed, its input goes through the microcontroller; the microcontroller takes to control the relay action. The relay is activated by very few transistor controlled voltage but it provides the voltage depend on the motor driving from the uncontrolled supply voltage. The motor can work efficiently by the way of switching relay. The below table shown the discussion of result obtained.

Time taken by weeding mechanism in minutes	Time taken by spraying mechanism in minutes	Time taken by sensing moisture content in minutes	Total time taken by overall system in minutes
01	03	01	05



Fig.7 Photo snaps of weeding mechanism



Fig.8 Testing of prototype module



Fig.8 Sprayer photo snap

VI. CONCLUSION

The progress in science & technology is a non-stop process. New things and new technology are being invented. As the technology grows day by day, we can imagine about the future in which thing we may occupy every place. The proposed system based on PIC microcontroller [microchip] is found to be more compact, user friendly and less complex, which can readily be used in order to perform several tedious and repetitive tasks. Though it is designed keeping in mind about the need for industry, it can extended for other purposes such as commercial & research applications. Due to the probability of high technology (PIC microcontroller) used this “Implementation of Spray and Weeding Robot Using Mobile Control for Agriculture Field” is fully software controlled with less hardware circuit. The feature makes this system is the base for future systems.

VII. ACKNOWLEDGEMENT

We express to wish our sincere thanks for “The Institution of Engineers (India)”, Kolkata for funding the project.

## REFERENCES

- [1] Albert-Jan Baerveldt, Björn Åstrand An Agricultural Mobile Robot with Vision-Based Perception for Mechanical Weed Control, Springer – Journal of Autonomous robots, July 2002, Volume 13, Issue 1, pp 21–35
- [2] Åstrand, B. and Baerveldt, A.J. 1999a. Mechatronics in agriculture—robust recognition of plant rows. In 2nd International Conference on Recent Advances in Mechatronics (ICRAM'99), Istanbul, Turkey, pp. 135–141.
- [3] Åstrand, B. and Baerveldt, A.J. 1999b. Robust tracking of plant rows using machine vision. In Sixth International Conference on Mechatronics and Machine Vision in Practice, Middle East Technical University, Ankara, Turkey, pp. 95–101.
- [4] Åstrand, B. and Baerveldt, A.J. 2000. A vision based row-following system for agricultural robots. In Proceedings of the Symposium on Image Analysis, Swedish Society for Automated Image Analysis (SSAB), Halmstad, Sweden, pp. 113–117.
- [5] Baerveldt, A.J. 1997. Vision-guided mechanical weed-control. In 2nd International Workshop on Mechatronic Computer Systems for Perception and Action (MCPA'97), Pisa, Italy, pp. 135–138.
- [6] Becker, B. 1999. Development of the real time software for an agricultural robot. Diploma Thesis in Computer Science, Halmstad University—Fachhochschule Ulm.
- [7] Billingsley, J. and Schoenfisch, M. 1995. Vision-guidance of agricultural vehicles. *Autonomous Robots*, 2:65–76.
- [8] Bishop, C.M. 1997. *Neural Networks for Pattern Recognition*, Oxford University Press: New York.
- [9] Bondesson, F. Minas, M., and Winberg, U. 1998. Classification of sugar-beet plants among weeds using machine vision. Master Project Electrical Engineering, Halmstad University.
- [10] Brivot, R. and Marchant, J.A. 1996. Segmentation of plants and weeds for a precision crop protection robot using infrared images. *Proceedings of the IEE, Vision, Image and Signal Processing*, 143(2):118–124.
- [11] Harmon, S.Y., Bianchini, G.L., and Pinz, B.E. 1986. Sensor data fusion through a distributed blackboard. In 1986 IEEE International Conference on Robotics and Automation, San Francisco, CA, pp. 1449–1454.
- [12] Jain, A.K. 1989. *Fundamentals of Digital Image Processing*, Prentice Hall: Englewood Cliffs, New Jersey.
- [13] Lee, W.S. Slaughter, D.C., and Giles, D.K. 1997. Robotic weed control systems for tomatoes using machine vision system and precision chemical applications. In *Proceedings of the 1997 ASAE Annual International Meeting*, Minneapolis, Minnesota, Paper No. 97–3093.
- [14] Marchant, J.A. 1996. Tracking of row structure in three crops using image analysis. *Computer and Electronics in Agriculture*, 15(2):161–179.
- [15] Marchant, J.A. and Brivot, R. 1995. Real-time tracking of plant rows using a Hough transform. *Real-Time Imaging*, 1:363–371.
- [16] Ollis, M. and Stentz, A. 1996. First result in vision based crop line tracking. In *Proceedings of the 1996 IEEE International Conference on Robotics and Automation*, Minneapolis, Minnesota, pp. 951–956.
- [17] Otsu, N. 1979. A threshold selection method from gray-level histograms. *IEEE Trans. on Systems Man and Cybernetics*, 9(1):63–66.
- [18] Shapiro, L.G. and Haralick, R.M. 1992/1993. *Computer and Robot Vision Volume I and II*, Addison, Wesley Publishing Company: Reading, MA.
- [19] Slaughter, D.C., Chen, P., and Curley, R.G. 1997. Computer vision guidance system for precision cultivation. In *ASAE Meeting Presentation*, Minneapolis, Minnesota, Paper No. 97–1079.
- [20] Tillett, N.D., Hague, T., and Marchant, J. A. 1998. A robotic system for plant-scale husbandry. *Journal of Agricultural Engineering Research*, 69:169–178.