

# An Adaptive Fuzzy Repetitive Control Scheme for Harmonic Suppression of Circulating Current in Modular Multilevel Converters

Mr. M.Siva Reddy<sup>1</sup>, T. Naveen<sup>2</sup>,

<sup>1</sup>Assistant professor, Newton's Institute of Engineering

<sup>2</sup>PG student, Newton's Institute of Engineering

**Abstract-** In a modular multilevel converter (MMC), the interaction between switching actions and fluctuating capacitor voltages of the submodules results in second- and other even-order harmonics in the circulating currents. These harmonic currents will introduce extra power loss, increase current stress of power devices, and even cause instability during transients. Traditional methods for circulating current harmonic suppression have problems such as limited harmonic rejection capability, limited application area, and complex implementation.

This paper presents a plug-in repetitive control scheme with fuzzy logic controller is implemented to solve the problem. It combines the high dynamics of fuzzy controller and good steady-state harmonic suppression of the repetitive controller, and minimizes the interference between the two controllers. It is suitable for multiple harmonic suppression, easy to implement, and applicable for both single-phase and three-phase MMCs. Simulation and experimental results on a singlephase MMC inverter proved the validity of the proposed control method.

## I. INTRODUCTION

Multilevel converters have successfully made their way into industrial high-power applications. Among the multilevel topology family, the modular multilevel converter (MMC) is attracting increasing interests for the advantages of modular structure, inherent redundancy, distributed and reliable dc capacitors, improved power quality, four-quadrant operation, freedom from multiple isolated dc sources, ease of expandability, In a modular multilevel converter, the chief ripple component of the submodule (SM) capacitor voltage is the fundamental one. It can produce second-order harmonic in the output voltage of the SMs. The latter then causes second-order harmonic in the circulating current that

flows through the dc source and the phase leg. Without proper control, the amplitude of the second-order circulating current can be significant, and it can trigger a series of higher, even-order current harmonics.

## II. CONCEPT OF MULTILEVEL CONVERTER

Power quality is the set of limits of electrical properties that allows electrical systems to function in their intended manner without significant loss of performance or life. The term is used to describe electric power that drives an electrical load and the load's ability to function properly with that electric power. Without the proper power, an electrical device (or load) may malfunction, fail prematurely or not operate at all. There are many ways in which electric power can be of poor quality and many more causes of such poor quality power

The electric power industry comprises electricity generation (AC power), electric power transmission and ultimately electricity distribution to an electricity meter located at the premises of the end user of the electric power. The electricity then moves through the wiring system of the end user until it reaches the load. The complexity of the system to move electric energy from the point of production to the point of consumption combined with variations in weather, generation, demand and other factors provide many opportunities for the quality of supply to be compromised.

An inverter is an electrical device that converts direct current (DC) to alternating current (AC); the converted AC can be at any required voltage and frequency with the use of appropriate transformers, switching, and control circuits.

Static inverters have no moving parts and are used in a wide range of applications, from small switching power supplies in computers, to large electric utility high-voltage direct current applications that transport bulk power. Inverters are commonly used to supply AC power from DC sources such as solar panels or batteries.

The electrical inverter is a high-power electronic oscillator. It is so named because early mechanical AC to DC converters was made to work in reverse, and thus were "inverted", to convert DC to AC.

**CASCADED H-BRIDGES INVERTER:**

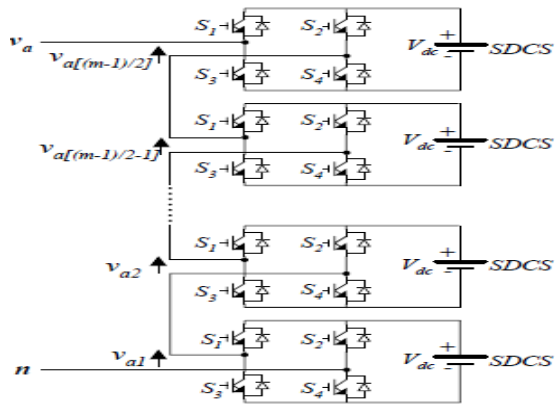

Single-phase structure of a cascaded H-bridge inverter

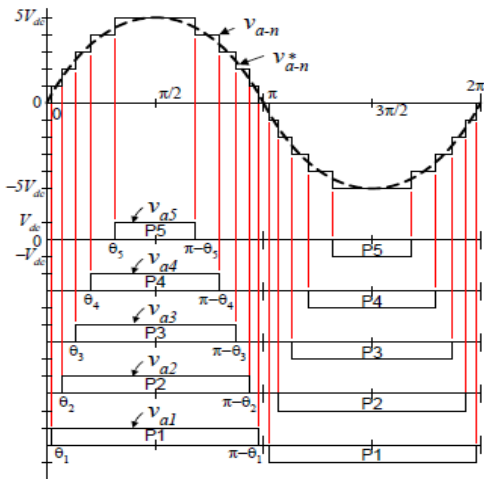

Output phase voltage waveform of an 11-level cascade inverter with 5 separate dc sources

**DIODE-CLAMPED MULTILEVEL INVERTER:**

The neutral point converter proposed by Nabae, Takahashi, and Akagi in 1981 was essentially a three-level diode-clamped inverter. In the 1990s several

researchers published articles that have reported experimental results for four-, five-, and six-level diode-clamped converters for such uses as static VAR compensation, variable speed motor drives, and high-voltage system interconnections.

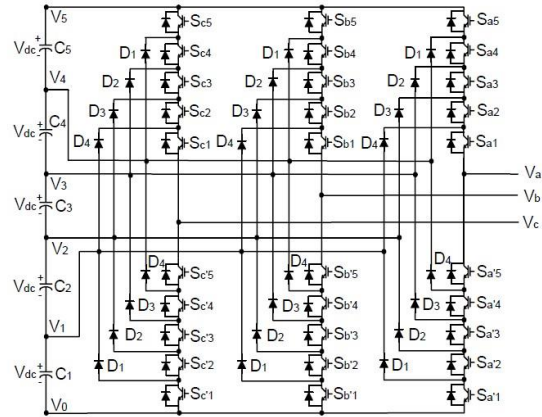

Three-phase six-level structure of a diode-clamped inverter.

**FLYING CAPACITOR MULTILEVEL INVERTER:**

Meynard and Foch introduced a flying-capacitor-based inverter in 1992. The structure of this inverter is similar to that of the diode-clamped inverter except that instead of using clamping diodes, the inverter uses capacitors in their place. The circuit topology of the flying capacitor multilevel inverter is shown in Figure 31.7. This topology has a ladder structure of dc side capacitors, where the voltage on each capacitor differs from that of the next capacitor. The voltage increment between two adjacent capacitor legs gives the size of the voltage steps in the output waveform

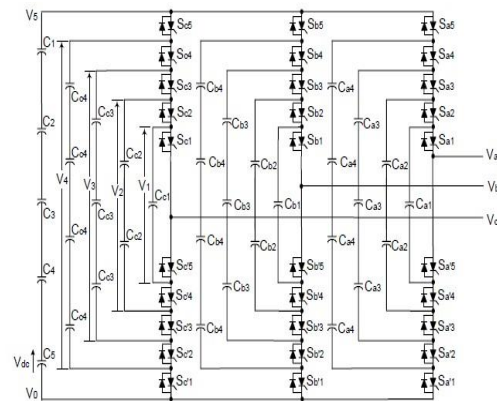

Three-phase six-level structure of a flying capacitor inverter

One advantage of the flying-capacitor-based inverter is that it has redundancies for inner voltage levels; in other words, two or more valid switch combinations can synthesize an output voltage. Table 31.2 shows a list of all the combinations of phase voltage levels that are possible for the six-level circuit shown in Figure 31.7. Unlike the diode-clamped inverter, the flying-capacitor inverter does not require all of the switches that are on (conducting) be in a consecutive series.

### III. MODELING AND ANALYSIS OF CIRCULATING CURRENT

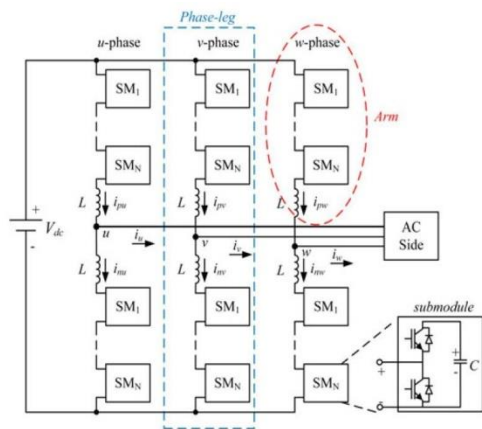

The total output voltages of the SMs in the upper (or lower) arm of each phase can be modeled as controlled voltage sources  $v_{px}$  (or  $v_{nx}$ ), as shown in Fig. 2(a). The circulating current is defined as

$$i_{zx} = (i_{px} + i_{nx})/2. \tag{1}$$

$$\begin{cases} v_{px} = \frac{V_{dc}}{2} - v_x - L \frac{di_{px}}{dt} - Ri_{px} \\ v_{nx} = \frac{V_{dc}}{2} + v_x - L \frac{di_{nx}}{dt} - Ri_{nx} \end{cases} \tag{2}$$

$$\begin{cases} i_{px} = i_{zx} + \frac{i_x}{2} \\ i_{nx} = i_{zx} - \frac{i_x}{2} \end{cases} \tag{3}$$

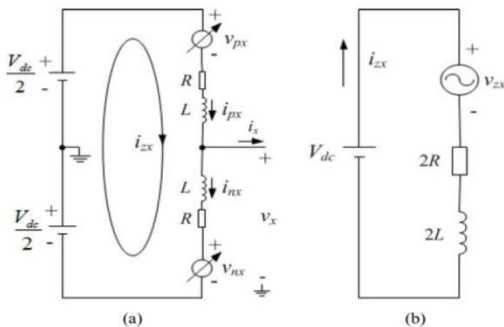

Substituting (3) into (2) yields

$$2L \frac{di_{zx}}{dt} + 2Ri_{zx} = V_{dc} - (v_{px} + v_{nx}). \tag{4}$$

Therefore, the control of  $i_{zx}$  is realized by adjusting  $(v_{px} + v_{nx})$ , i.e., the common mode component of the arm voltages, defined as  $v_{zx}$ . The equivalent circuit of  $i_{zx}$  is shown in Fig. 2(b). According to [5] and [6], if the modulating signals for the SMs are purely

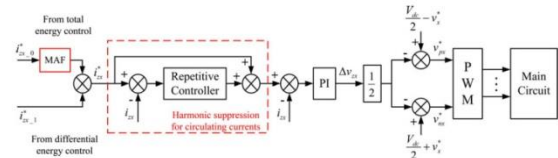

Overall circulating current control of MMC (for phase x).

normal components of the arm voltage references ( $V_{dc} \cos \omega t - v_x$  and  $V_{dc} \cos \omega t + v_x$ ) to form the final references ( $v_{*px}$  and  $v_{*nx}$ ).  $v_{*x}$  is the desired ac output voltage of phase x

$$v_x^* = M \frac{V_{dc}}{2} \sin(\omega t + \varphi_x), \quad M \in [0, 1]. \tag{5}$$

### IV. DESIGN AND ANALYSIS OF THE PROPOSED REPETITIVE CONTROLLER

For its better transient performance, the PI control is kept as a preliminary measure of harmonic suppression. The block diagram and the Bode plot of the PI controlled circulating current loop are as shown in Fig. 4. The transfer function of the PI controller is:

$$PI(s) = \frac{K_p s + K_i}{s}. \tag{6}$$

According to (3), the transfer function of plant  $G(s)$  is

$$G(s) = \frac{1}{2Ls + 2R}. \tag{7}$$

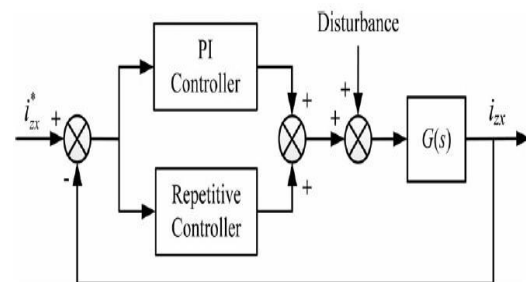

Control structure of pi based controller

In [15], a repetitive controller is paralleled with the PI controller to improve harmonic suppression. The resulted control structure is shown in Fig. 5. Such a parallel configuration of a repetitive controller and the existing high-dynamic controller (the PI controller in this case) can also be found in [17]–[20]. In this paper, however, a different structure as shown in Fig. 6 is adopted. An important consideration behind a parallel structure is perhaps the transient performance. It seems that by paralleling the two controllers instead of cascading them, the quick response of the PI controller will not be affected by the slow repetitive controller. But the seemingly “cascaded” structure in Fig. 6 can also

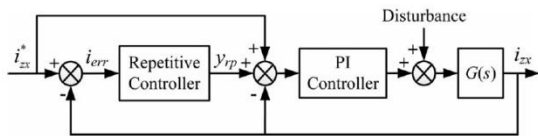

Proposed plug-in repetitive control structure.

The proposed control structure also provides a more friendly “plant” for the repetitive controller. In Fig. 6 or Fig. 7, the plant (i.e., all the dynamics from  $y_{rp}$  to  $i_{zx}$ ) as seen from the repetitive controller is the PI-controlled circulating current loop, with the transfer function

$$P(s) = \frac{PI(s)G(s)}{1 + PI(s)G(s)} \tag{8}$$

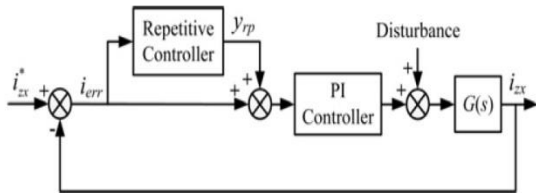

Equivalent form

The frequency characteristics of  $P(s)$  has already been given in Fig. 4(b). It exhibits unity gain from zero frequency up to the break frequency, and then a monotonically decreasing gain after the break frequency. This is a frequency characteristic that is most desirable for the repetitive controller design [23]. With the parallel structure, the plant of the repetitive control is

$$P'(s) = \frac{G(s)}{1 + PI(s)G(s)} \tag{9}$$

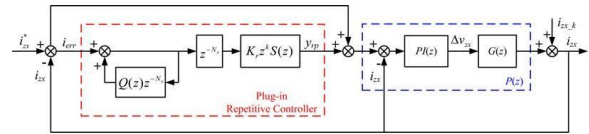

Detailed block diagram of the proposed repetitive control scheme for circulating current.

Upper arm current  $i_{fp}$ , lower arm current  $i_{fn}$ , and circulating current  $i_z$  (simulation results). (a) With PI

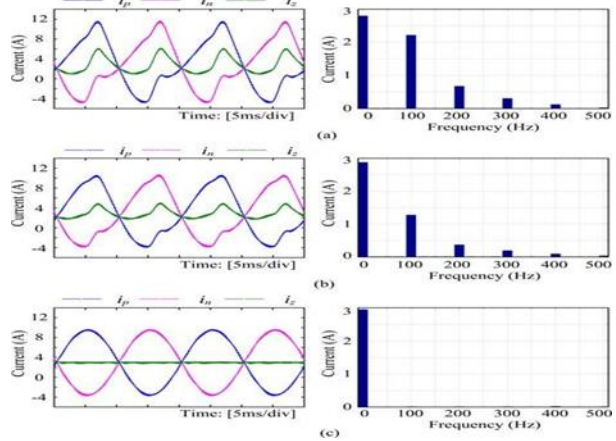

controller only. (b) With MAF + PI controller. (c) With MAF + PI controller +proposed repetitive controller

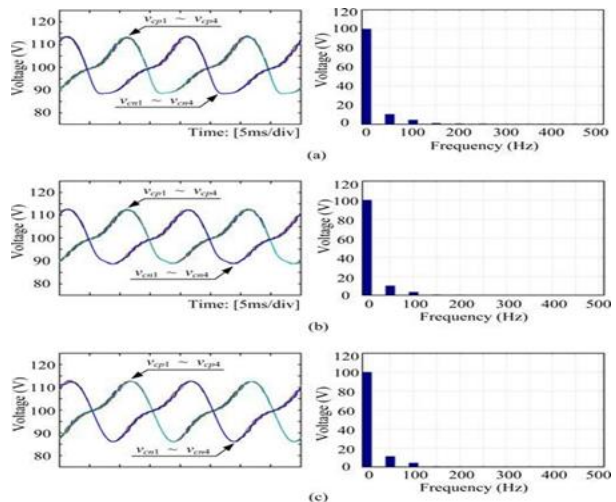

Capacitor voltages of all SMs in one phase leg (simulation results).With PI controller only. (b) With MAF + PI controller. (c) With MAF + PI controller +proposed repetitive controller. reduced, indicating better command-following and disturbance rejection at these frequencies.

### B. Harmonic Rejection Ability

The transfer function of a repetitive controller

$$z^{N_s} i_{err}(z) = H(z) i_{err}(z) \tag{14}$$

FUZZY LOGIC:

In recent years, the number and variety of applications of fuzzy logic have increased significantly. The applications range from consumer products such as cameras, camcorders, washing machines, and microwave ovens to industrial process control, medical instrumentation, decision-support systems, and portfolio selection.

To understand why use of fuzzy logic has grown, you must first understand what is meant by fuzzy logic.

Fuzzy logic has two different meanings. In a narrow sense, fuzzy logic is a logical system, which is an extension of multivalve logic. However, in a wider sense fuzzy logic (FL) is almost synonymous with the theory of fuzzy sets, a theory which relates to classes of objects with unsharp boundaries in which membership is a matter of degree. In this perspective, fuzzy logic in its narrow sense is a branch of fl. Even in its more narrow definition, fuzzy logic differs both in concept and substance from traditional multivalve logical systems.

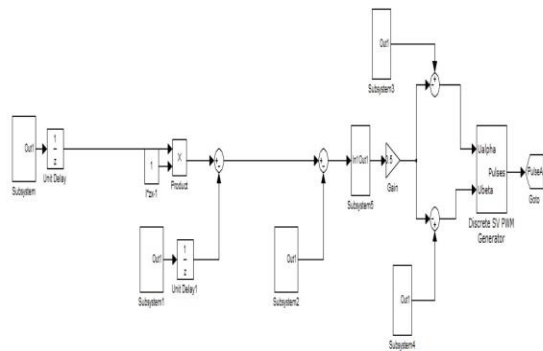

V. SIMULATION RESULTS

A simulation model of a single-phase MMC inverter is established in MATLAB/Simulink to verify the proposed control scheme. The parameters are already given in Table I. Three cases are simulated: 1)  $i_z$  is controlled by the PI controller only; 2) the moving average filter (MAF) is added; and 3) the proposed repetitive controller is also added. The arm currents and circulating currents in the steady state are shown in Fig. 13, which indicates that the moving average filter provides positive but limited effect on harmonic suppression, while the proposed repetitive controller can eliminate nearly all the harmonics in the circulating current.

The peak values of arm currents in the above three cases are respectively 11.7, 10.6, and 9.2 A. The reduced peak current is beneficial for the power devices. This advantage becomes more important for high-power applications. Now that the circulating current is rid of the second-order content, the dc source of the MMC no longer supplies the second-order ripple power consumed by the single-phase load. The latter then has to be supplied solely by the SM capacitors.

(a) Submodules of the MMC inverter



(a) Submodules of the MMC inverter

(b) DSP+FPGA control panel

The above simulation results are for a single-phase MMC inverter. In a three-phase MMC inverter, the circulating current of each phase can be controlled independently. Therefore, the proposed control scheme can be directly applied to three-phase scenario"

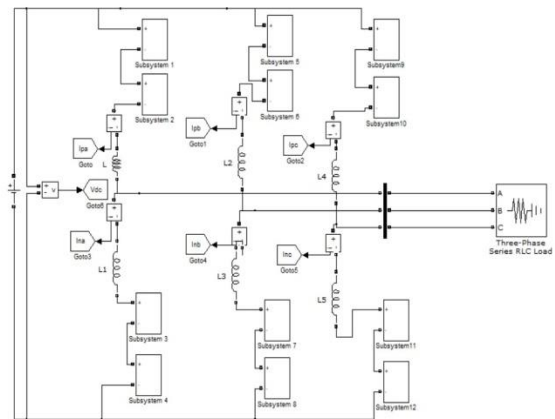

The topology of a three-phase MMC inverter.

control system with fuzzy logic system  
CASE A: Steady-State Performance

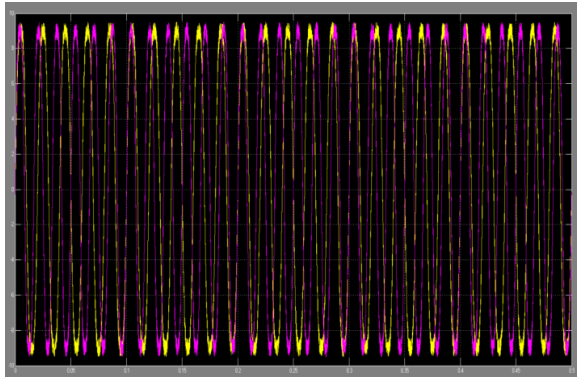

Upper arm current  $i_p$  , lower arm current  $i_n$  , and circulating current  $i_z$  proposed repetitive control scheme with fuzzy logic controller

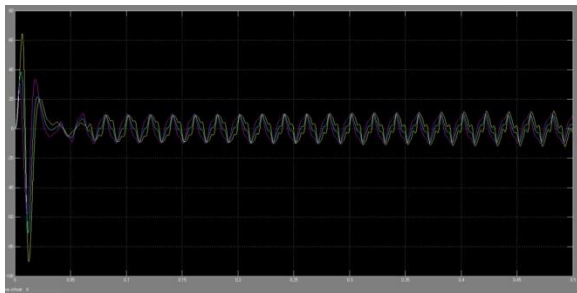

AC output voltage  $v_o$  and current  $i_o$  (with proposed control scheme)

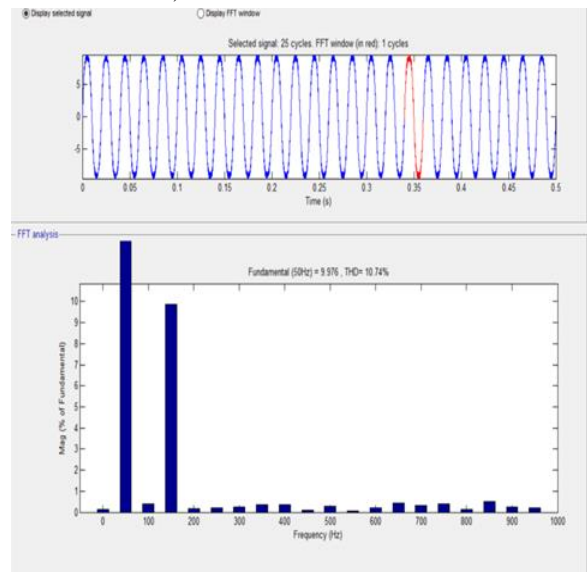

FFT analysis for case A

## VII. CONCLUSION

The second-order as well as other higher order harmonics in circulating current brings extra power losses and may affect stable operation of the MMC. This paper proposed a “Fuzzy + Repetitive” control

scheme to suppress these harmonics in the circulating current. It greatly improves the harmonic suppression of the conventional PI controller. It is applicable to both single-phase and three-phase systems, and is able to eliminate multiple harmonics with a single controller. Compared with another “PI + Repetitive” control scheme in which the two controllers are paralleled, the control structure proposed in this paper results in a more friendly plant for the repetitive controller, and poses no design limit on the PI controller.

Simulation experiments are made on a single-phase MMC inverter. The results show good harmonic suppression of the proposed control scheme, and indicate that the plug-in repetitive controller does not affect the transient performance of the PI controller. The results also show that after the second-order harmonic in the circulating current is cut out, there is no significant increase of second-order ripple in the SM capacitor voltages.

## REFERENCES

- [1] S. Kouro, M. Malinowski, K. Gopakumar, J. Pou, L. G. Franquelo, B. Wu, J. Rodriguez, M. A. Pérez, and J. I. Leon, “Recent advances and industrial applications of multilevel converters,” *IEEE Trans. Ind. Electron.*, vol. 57, no. 8, pp. 2553–2580, Aug. 2010.
- [2] A. Lesnicar and R. Marquardt, “An innovative modular multilevel converter topology suitable for a wide power range,” in *Proc. IEEE Power Tech Conf.*, 2003, pp. 1–3.
- [3] M. Glinka and R. Marquardt, “A new AC/AC multilevel converter family,” *IEEE Trans. Ind. Electron.*, vol. 52, no. 3, pp. 662–669, Jun. 2005.
- [4] H. Akagi, “Classification, terminology, and application of the modular multilevel cascade converter (MMCC),” *IEEE Trans. Power Electron.*, vol. 26, no. 11, pp. 3119–3130, Nov. 2011.
- [5] Q. Song, W. Liu, X. Li, H. Rao, S. Xu, and L. Li, “A steady-state analysis method for a modular multilevel converter,” *IEEE Trans. Power Electron.*, vol. 28, no. 8, pp. 3702–3713, Aug. 2013.
- [6] K. Ilves, A. Antonopoulos, S. Norrnga, and H.-P. Nee, “Steady-state analysis of interaction

- between harmonic components of arm and line quantities of modular multilevel converters,” *IEEE Trans. Power Electron.*, vol. 27, no. 1, pp. 57–68, Jan. 2012.
- [7] A. Antonopoulos, L. Angquist, and H.-P. Nee, “On dynamics and voltage control of the modular multilevel converter,” in *Proc. Eur. Conf. Power Electron. Appl.*, Barcelona, Spain, Sep. 8–10, 2009, pp. 1–10.
- [8] L. Angquist, A. Antonopoulos, D. Siemaszko, K. Ilves, M. Vasiladiotis, and H. Nee, “Inner control of modular multilevel converters—An approach using open-loop estimation of stored energy,” in *Proc. Int. Power Eng. Conf.*, Sapporo, Japan, Jun. 21–24, 2010, pp. 1579–1585.
- [9] K. Ilves, A. Antonopoulos, L. Harnefors, S. Norrga, and H.-P. Nee, “Circulating current control in modular multilevel converters with fundamental switching frequency,” in *Proc. Int. Power Electron. Motion Control Conf.*, Harbin, China, Jun. 2–5, 2012, pp. 249–256.
- [10] M. Hagiwara and H. Akagi, “Control and experiment of pulsewidthmodulated modular multilevel converters,” *IEEE Trans. Power Electron.*, vol. 24, no. 7, pp. 1737–1746, Jul. 2009.
- [11] Q. Tu, Z. Xu, and L. Xu, “Reduced switching-frequency modulation and circulating current suppression for modular multilevel PWM Converters,” *IEEE Trans. Power Del.*, vol. 26, no. 3, pp. 2009–2017, Jul. 2011.
- [12] X. She and A. Huang, “Circulating current control of double-star chopper cell modular multilevel converter for HVDC system,” in *Proc. Annu. Conf. IEEE Ind. Electron. Society*, IETSMontréal, QC, Canada, Oct. 25–28, 2012, pp. 1234–1239.