

Minimization of THD for 29-Level Asymmetrical Multilevel Inverter Using Genetic Algorithm

S. Gayathri¹, M. Thamilarasi², Aadyasha Patel³

^{1,2} UG Student, EEE, B.E, Prince Shri Venkateshwara Padmavathy Engineering College, Tamilnadu

³Assistant Professor, M.Tech, EEE, Prince Shri Venkateshwara Padmavathy Engineering College

Abstract- Multilevel inverters have many benefits viz., low cost, good efficiency, better reliability and etc, and some application such as PV panels and fuel cells. This work presents a 29-level Asymmetric Cascaded H-bridge MLI that uses the Genetic Algorithm. Optimized gating angles are proposed using GA. In this paper, minimization of THD is done by adjusting switching times of switches for 29-level inverter. For this purpose, first THD is defined as a function of these switching angles and then for minimization of this function, the optimization algorithm GA is used. The proposal is validated in frequency domain and FFT analysis is done.

Index Terms- Multilevel inverter (MLI), Genetic algorithm (GA), Photo voltaic (PV), Total Harmonic Distortion (THD), Fast Fourier Transform (FFT).

I. INTRODUCTION

Nowadays, DC-AC converters are essential in power electronics applications, such as motor drives, renewable sources integration, reactive power compensation, just to name a few. One of the main concerns in this matter are the harmonics generated in the AC waveforms due to the commutating frequency of the power switches. An attractive alternative to mitigate the negative effects of the unwanted switching harmonics, is the use of multilevel converters; which have been a widespread solution for power conversion in different fields [1]. Among the multilevel converters, a growing technological trend is the asymmetric multilevel converter, which can generate a high number of levels, depending on the amount of power switches and the asymmetry ratios. In fact, these converters – with the same number of semiconductor devices than their symmetric counterpart – can achieve higher amount of levels [2] and therefore reduce the switching harmonics in the resulting AC waveform.

II. MULTILEVEL INVERTER

The MLIs have been recently drawing growing attention especially in distributed energy resources (DER). These MLIs can be applied for batteries, fuel cells, solar cells, wind and microturbine. Also, MLIs can be used to feed a load or connected to ac grid without balancing problems. An advantage of MLIs is that their switching frequency is lower than traditional inverters that means the switching losses are decreased. These MLIs [3] has increased the output voltage and introduced a solution to limitation of classical semiconductor switches.

Fig.1 illustrates some of advantage of the H-bridge MLI. The technology of MLIs is based on production different DC voltage levels and composition of these levels to obtain better output voltage waveform. The output voltage waveform by adding step has lower total harmonic distortion (THD) and reduced the harmonics in comparison to square wave inverters. MLIs can have one of three basic types: cascaded H-bridge, diode clamped and flying capacitor converters. A cascaded MLI has two or more separate DC voltage sources that can be batteries, fuel cells or solar cells or other independent sources of DC voltage. Cascaded MLI has a modular topology and for this reason, it has higher reliability and can achieve higher output voltage.

Cascaded H-bridge are classified based on DC input source applied, in two types: The Symmetric Multilevel Inverter (with equal DC voltage source) and Asymmetric Multilevel Inverter (with unequal DC voltage source). Different switching methods for reducing harmonics and THD of output voltage waveform such as sinusoidal pulse width modulation (PWM) and space vector PWM schemes are suggested. Although, these methods are useful the PWM schemes are complex and increases the switching frequency. In this, a method for tuning

switching angles with genetic algorithm (GA) is presented. Analytical process for solution in case of unequal DC sources is proposed and, algorithms to solve for the angles is presented. In this paper, first the topology of asymmetrical MLI is described. Then switching table for a 29-level inverter is stated. In third section of paper a review of optimization method used in paper is done [4]. An algorithm GA is used to optimize THD in MLI. Theoretical and Simulated results are presented. Finally, a conclusion of paper is presented.

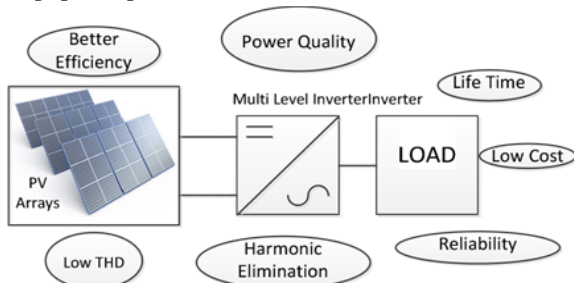

Fig 1 Some of the advantages of H-bridge MLI

III.GENETIC ALGORITHM

The genetic algorithm(GA) is a method for solving both constrained and unconstrained optimization problems based on a natural selection process that is inspired from biological evolution process. At each step, the GA randomly selects the individuals from the current population and uses them as parents to produce the children for the next generation. Over successive generations, the population evolves an Optimal solution.

By using Fourier series analysis for output voltage waveform, it can be written as follows:

$$V_o(t) = \sum_{n=1}^{\infty} \frac{4V_{dc}}{n\pi} (\cos(n\alpha_1) + \cos(n\alpha_2) + \dots + \cos(n\alpha_{14}))$$

The following steps summarizes how the Genetic Algorithm works:

1. The algorithm begins by creating a random initial population.
2. It then, creates a sequence of new populations at each step, the individuals in the current step creates next population in the following steps:
 - a. Computation of fitness value.
 - b. Converts into more usable range of values.

- c. Selects members called parents, based on usable values.
 - d. The lower fit individuals are passed to the next generation.
 - e. Produces children from the parents. It can be done by either Mutation or crossover.
 - f. Current population is replaced by the children to form next generation.
3. When the stopping conditions are met, it can be stopped.

In this paper, the Genetic Algorithm is used as an Optimization Algorithm in order to minimize the THD, by varying the switching angles of the MLI.

The aim is to determine the optimum switching angles that generate an output voltage with the required fundamental component and the possible minimum THD. This is a problem to be solved by an optimization algorithm. In this paper, GA is used which is a simple, powerful, and evolutionary technique, inspired from the laws of natural selection and genetics. It is a general-purpose stochastic global search algorithm, with no need of functional derivative information to search for the solutions that minimize (or maximize) a given objective function. GA reduces the computational burden and search time, while solving complex objective functions. The number of iterations used here is 100.

IV.PRINCIPLE OF OPERATION

The principle used in this paper can be explained with the help of the following circuit diagram shown in fig 2.

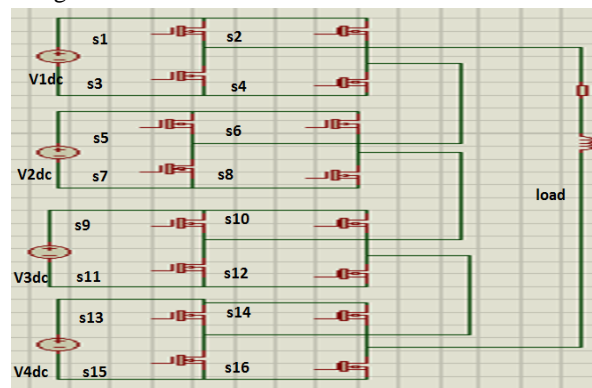

Fig 2 Circuit diagram of proposed system

It consists of several MOSFET switches, which has higher efficiency in low power applications compared to other semi-conductor switches. It also consists of the RL-load, different voltage sources

(asymmetric voltages). The mode of operation will be explained as below in fig.3. The mode of operation for producing a voltage of 1V is shown, likewise the other modes of operation can be configured in a similar manner. For various levels of voltage, different modes of operation are used in order to produce the desired output voltages. This can be described in the following table shown in fig.4. It depicts the quarter half-cycle operation.

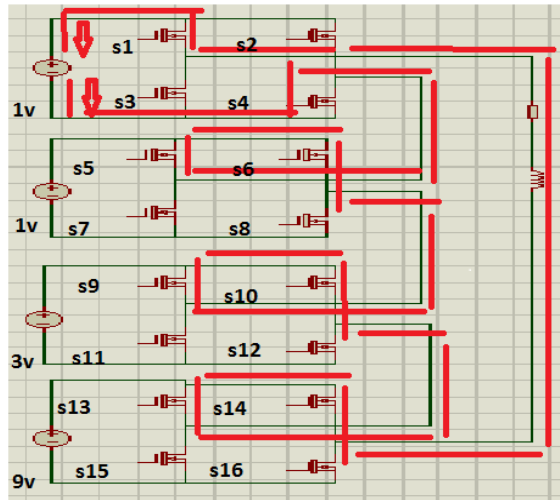

Fig 3 Mode of operation

	0	1	2	3	4	5	6	7	8	9	10	11	12	13	14
S1	1	1	1	1	1	1	1	0	0	1	1	1	1	1	1
S2	1	0	0	1	0	0	1	1	1	1	0	0	1	0	0
S3	0	0	0	0	0	0	0	1	1	0	0	0	0	0	0
S4	0	1	1	0	1	1	0	0	0	0	1	1	0	1	1
S5	1	1	1	1	1	1	1	0	1	1	1	1	1	1	1
S6	1	1	0	1	1	0	1	1	1	1	1	0	1	1	0
S7	0	0	0	0	0	0	0	1	0	0	0	0	0	0	0
S8	0	0	1	0	0	1	0	0	0	0	0	1	0	0	1
S9	1	1	1	1	1	1	0	1	1	1	1	1	1	1	1
S10	1	1	1	0	0	0	1	1	1	1	1	1	0	0	0
S11	0	0	0	0	0	0	1	0	0	0	0	0	0	0	0
S12	0	0	0	1	1	1	0	0	0	0	0	0	1	1	1
S13	1	1	1	1	1	1	1	1	1	1	1	1	1	1	1
S14	1	1	1	1	1	1	0	0	0	0	0	0	0	0	0
S15	0	0	0	0	0	0	0	0	0	0	0	0	0	0	0
S16	0	0	0	0	0	0	1	1	1	1	1	1	1	1	1

Fig 4 Table Showing the Switching Pattern

V. SOFTWARE SIMULATIONS

The MATLAB/Simulink software is used for the simulation of the MLI. The input voltage waveform is given by fig.5

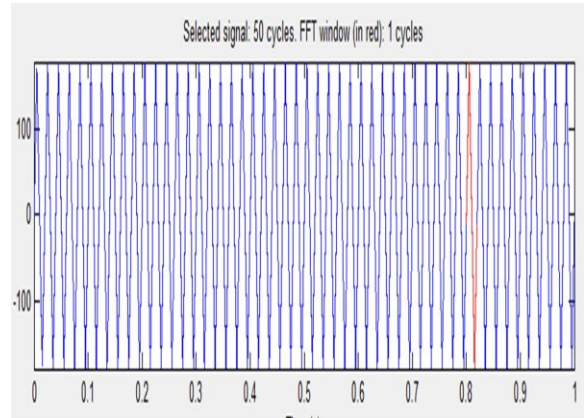

Fig 5 Input Voltage Waveform

It consists of harmonics, which are minimized by implementing the GA. The output waveforms are shown in fig.6 and fig.7

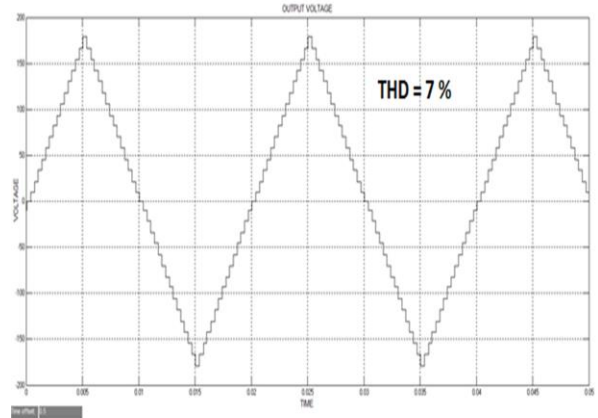

Fig 6 Output Waveform

The output waveform is nearly sinusoidal with THD of about 7% which is comparatively less than the existing methods.

The output waveform is analysed using FFT analysis and the output is represented in frequency domain viz., in discrete form as shown in fig.7.

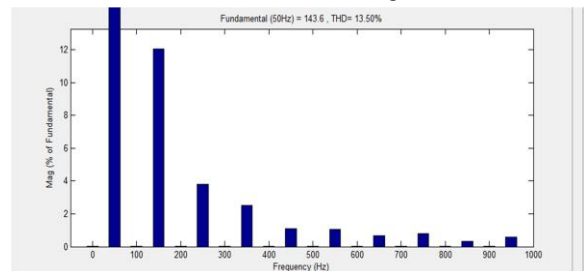

Fig 7 FFT Analysis of Output Waveform

The simulation is done by modelling the hardware components and by feeding in the values of the optimized switching angles, which are the results of the GA. The simulation diagram is shown in fig.8

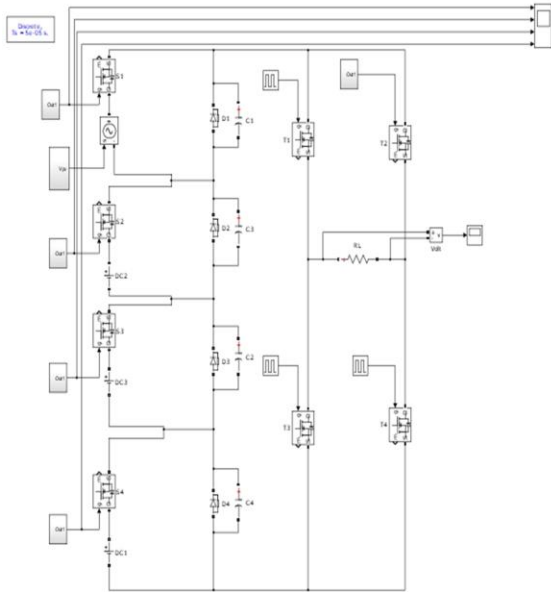

Fig 8 Simulation Diagram

VI.HARDWARE IMPLEMENTATION

The hardware components used in this paper are MLI, power supply unit, CRO, driver circuit and PIC micro-controller. They are explained as below:

1.Driver circuit

The driver circuit is supplied using a step-down transformer 230V/12V AC. In, this paper, the driver circuit is mainly used to amplify the pulse output coming from the microcontroller circuit. The opto-coupler is used to isolate the voltages between the main circuit and microcontroller circuit.

2.Multi-level inverter

The multi-level inverter circuit consists of asymmetrical cascaded H-bridge inverters consisting of MOSFETs and RL-load. The various switches used can be MOSFET, IGBT, GTO etc depending upon the applications.

3.Power supply unit

All the electronic components starting from diode to Intel IC's only work with a DC supply ranging from -+5V to 0+12V. We are utilizing the same, cheapest and commonly available energy source of 230V-50Hz by stepping down, rectifying, filtering and regulating the voltage.

4.PIC Micro-controller

We are using PIC 16F877A for producing switching pulses to multilevel inverter. This eliminates

common mode voltage. Also, it is used to eliminate capacitor voltage unbalancing. The microcontroller is driven via the driver circuit, so as to boost the voltage, triggering signal to 9V. To avoid any damage to micro controller, due to direct passing of 230V supply to it, we provide an isolator in the form of optocoupler in the same driver circuit.

5. CRO

The cathode ray oscilloscope is used to view the output. The CRO is a common laboratory instrument that provides accurate time and amplitude measurements of voltage signals over a wide range of frequencies. It provides visual images of varying electrical quantities. In this paper, we use the CRO to view the output waveform. The measurement of THD can be done with the help of PQA (power quality analyzer). As it is not affordable, we can use the CRO to view the output waveform.

The hardware can be depicted with the help of the snapshot shown in fig.9. The overall circuit diagram that depicts the hardware modelling of the 29- level MLI is shown in fig.11

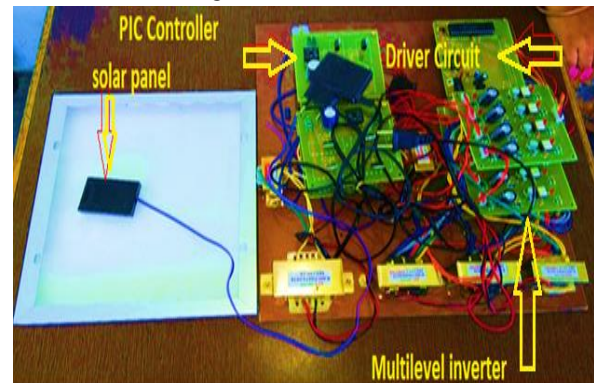

Fig 5 Hardware Snapshot

The output voltage displayed is viewed through the CRO. The output voltage for a 29-level inverter is shown in the fig.10

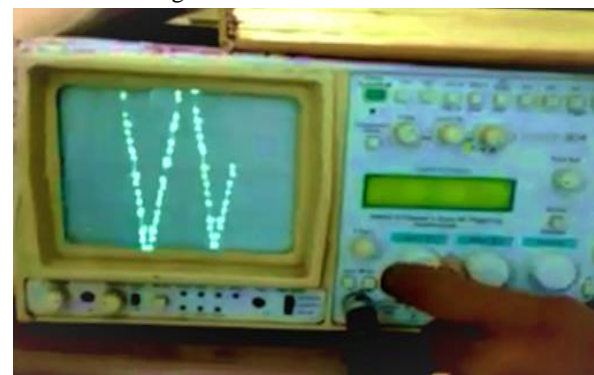

Fig 10 Snapshot of Output Voltage

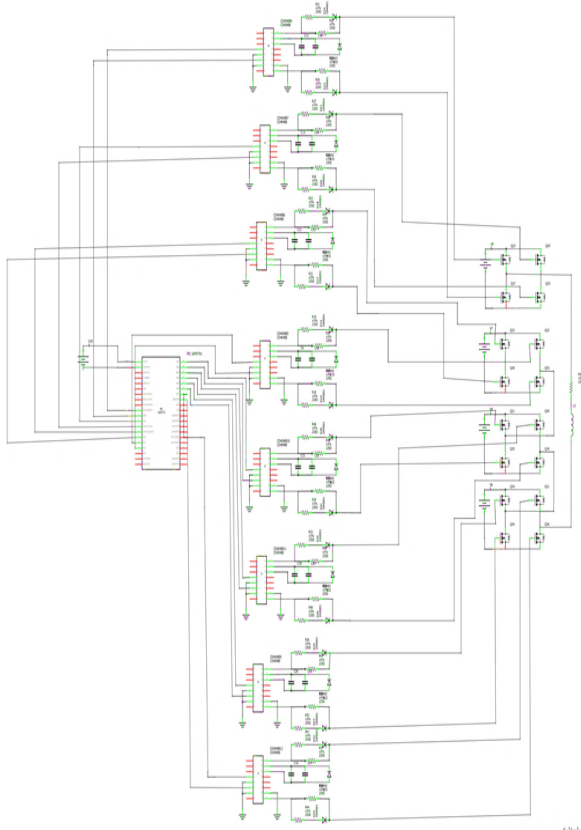

Fig 11 Overall Hardware Circuit Diagram

VII. CONCLUSION

In the proposed system, 29-level was achieved. In the future, nearly 43 levels can be achieved by increasing the switches. The different optimization algorithms can be used in order to limit the THD. The system can be applied in micro-grid applications, DC power source utilization, power factor compensators, back to back frequency link systems and interfacing with renewable energy resources.

VIII. FUTURE ENHANCEMENTS

1. Modeling and control of trinary asymmetric multilevel inverters in FACTS devices, HVDC transmission lines and large wind turbine applications can be studied as future work.
2. Future work related to this research is to perform complete realization of proposed multilevel inverter fed induction motor drive in closed loop control system.

3. Investigation of proposed multilevel inverters to replace the conventional inverters used in the micro-grid applications.

REFERENCES

- [1] J. Ye and A. Emadi, "Power electronic converters for 12/8 switched reluctance motor drives: A comparative analysis," 2014 IEEE Transportation Electrification Conference and Expo (ITEC), Dearborn, MI, 2014, pp. 1-6.
- [2] B. P. Kadu and J. A. Khobragade, "Investigation of cascaded H-Bridge multi-level Inverter as Distribution Static Compensator in Power System for compensation of reactive power and harmonics," 2015 International Conference on Energy Systems and Applications, Pune, 2015, pp. 432- 436.
- [3] J. Rodriguez, Jih-Sheng Lai and Fang Zheng Peng, "Multilevel inverters: a survey of topologies, controls, and applications," in IEEE Transactions on Industrial Electronics, vol. 49, no. 4, pp. 724738, Aug 2002.
- [4] M. Vasquez, J. Pontt and J. Vargas, "Predictive control of a Hybrid asymmetric multilevel converter with floating cells," 2014 IEEE International Conference on Industrial Technology (ICIT), Busan, 2014, pp. 278-283.
- [5] S. A. Verne, S. A. González and M. I. Valla, "A hybrid predictive controller for a Cascade Asymmetric Multilevel Converter," 2015 IEEE 24th International Symposium on Industrial Electronics (ISIE), Buzios, 2015, pp. 166-171.
- [6] L. David Pabón Fernández, E. A. Caicedo and J. L. Díaz Rodríguez, "Comparative analysis of 9 levels cascade multilevel converters with selective harmonic elimination," 2015 IEEE Workshop on Power Electronics and Power Quality Applications (PEPQA), Bogota, 2015, pp.
- [7] T. D. C. Busarello, J. A. Pomilio, A. S. Bubshait and M. G. Simões, "Staircase modulation- based battery storage system with Asymmetric Cascaded H-Bridge Multivel Inverter," 2015 IEEE Power & Energy Society General Meeting, Denver, CO, 2015, pp. 1-5.
- [8] M. S. A. Dahidah, G. Konstantinou and V. G. Agelidis, "A Review of Multilevel Selective Harmonic Elimination PWM: Formulations,

- Solving Algorithms, Implementation and Applications," in IEEE Transactions on Power Electronics, vol. 30, no. 8, pp. 4091-4106, Aug. 2015.
- [9] H. Hashim and I. Abdel-Qader, "Generalized solutions for THD investigation in cascaded multicell multilevel converters modulated with selective harmonic elimination PWM switching method," 2016 IEEE 7th Annual Ubiquitous Computing, Electronics & Mobile Co
- [10] Flores, P.; Dixon, J.; Ortuzar, M.; Carmi, R.; Barriuso, P.; Moran, L., "Static Var Compensator and Active Power Filter With Power Injection Capability, Using 27-Level Inverters and Photovoltaic Cells," Industrial Electronics, IEEE Transactions on, vol.56, no.1, pp.130,138, Jan. 2009.
- [11] J. Muñoz, P. Gaisse, C. Baier, M. Rivera, R. Gregor and P. Zanchetta, "Asymmetric multilevel topology for photovoltaic energy injection to microgrids," 2016 IEEE 17th Workshop on Control and Modeling for Power Electronics (COMPEL), Trondheim, 2016, pp. 1-6.
- [12] IEEE Recommended Practice and Requirements for Harmonic Control in Electric Power Systems," in IEEE Std 519-2014 (Revision of IEEE Std 519-1992), vol., no., pp.1-29, June 11 2014.