

Automated Smart Personal Transporter

mohanram.c¹, naganathan.n², nagaraj.g³, Nirmal.m.s⁴, dr.kalippan.e⁵

^{1,2,3,4} *UG students, Department of EEE, Easwari Engineering College, Chennai*

⁵ *HOD Associate professor, Department of EEE, Easwari Engineering College, Chennai*

Abstract- A fully functional self -balancing vehicle capable of bearing the human load as well as heavy loads is proposed in this paper. Requirement of the venture includes the designing and fabrication of the transporter, modeling of the system and implementation of control for stabilization. Indigenous electronic circuitry, voltage controller and four channel relay are used in the system. 500 Watt power DC motor makes this transporter capable of bearing the heavy lead. An ultrasonic sensor is used to detect the obstacles in the way. This transporter has one platform and two wheels on the sides and the rider stands on the platform. Our proposed system enables the user to transport both human and heavy loads and both and is capable of working in automatic and manual modes. The theoretical analysis of this paper will be verified by a hardware model.

Index Terms- Personal transporter, DC motor, Electric vehicle, Self balancing vehicle.

I. INTRODUCTION

With the recent developments of usage of sensors and electronics in a synergistic combination with the mechanical developments has led the emergence of innovative field of Mechatronics. This field has found itself a very prominent place in production, manufacturing, robotics etc. But in 2001, this field found itself a great application in the transportation field when DEAN KAMEN designed the “SEGWAY” a self balancing transportation device. Companies have constantly tried to make pollution free vehicles or environmentally friendly vehicles. Since the beginning of 21st century, air pollution, global warming, and the need of preserving conventional resources has pushed the designers to design green powered vehicles [6]. The self balancing vehicle is designed with intention for easy city transportation and can be considered as a small platform for experimentation by the engineers. This vehicle is also designed keeping in mind the ever increasing problem of air pollution and global

warming. The Self balancing personal transportation device was introduced in the year 2001 by Dean Kamen [6]. It is commercially manufactured by Segway Inc. of New Hampshire, USA [1]. The Segway HT is a vehicle which has two coaxial wheels driven independently by a controller that balances the vehicle both with and without a rider. The balancing is regulated by feedback from an array of tilt sensors and gyroscopes [9]. The self balancing human transportation device is based on the principle of inverted pendulum that will keep an angle of zero degrees with vertical at all times Ease of Use [2]. The device uses combined gyroscopic and accelerometer sensor to detect the motion of the rider so the vehicle can accelerate, brake or steer. This project uses combined fundamentals of mechanics, vehicle dynamics, control systems and programming [9]. This self balancing device uses Arduino Uno controller board, gyroscopic sensors and accelerometers and battery powered electric motors. This vehicle is a two coaxial wheeled device running on battery powered motors. The device has no brakes or accelerator, but has a handgrip for making turns. It is the only vehicle able to turn in place, just like a person, because its wheels have the ability to turn in opposite directions. For two-wheeled self balancing robots, stability is vital as they cannot remain upright (balanced) without effort [4].

II. LITERATURE SURVEY

The United States began regulating Segways in 2002, just after the product began to be marketed and a year after a media campaign promoting the Segway HT and its inventor Dean Kamen. At the time this report was written, 40 states and the District of Columbia had introduced regulations governing the use of Segway HTs on sidewalks, bicycle paths and some roads. The laws vary from state to state, but most define the Segway as an —electronic self balancing personal vehicle. Few states also resolute to redefine

the phenomenon pedestrian to include —a person using a Segway.[14] In fact, the first step toward approval of Segway HTs on sidewalks was adoption of national legislation in June 2002 that legalized their use on sidewalks under federal jurisdiction. This legislation defined the Segway HT as a new vehicle class an two wheel self balanced personal artifice separating it from other motorized vehicles such as scooters. However, Senate Bill 2024, which defines the Segway as an electric transportation device with a stabilized platform between two parallel wheels, gives states and local authorities the power to pass legislation governing the use of Segways at the regional and local level. It approves the use of Segways on sidewalks under federal authority and on private property. According to the Bill’s wording, the device —employs advances in technology and effectiveness to fully and safely integrate the user with personal transportation;|...—enables individuals to travel farther and carry more without use of traditional vehicles,|| and —promotes gains in utility; minimizes environmental impacts; and facilitates better use of public roadways.|| This two wheeled balanced aritfice is promoted as a viable transport alternative to other mainstream option. Additionally this robot has features suited to adventure, commuting, law enforcement and transportation in general[4].

Two-wheeled, self balancing systems are studied in many different concepts. They can be considered as robotic platform or as electric vehicle/transporter. Researchers focus on various issues besides the main problem stability. Segway Human Transporter (HT), which is invented by Dean Kamen, is known as the first two-wheeled, selfbalancing system in the literature. Flexibility, safety and performance are important due to being commercial product. Segway HT is demonstrated in fig. Also, Segway brings out two wheeled self balancing robotic platform which is called Robotics Mobility Platform (RMP)[5].



Fig.1 Segway

Hardware design

This section discussed the compositions of the hardware components and software implementations used for designing and constructing the project. The fabrication of the chassis and casing of the system are also discussed.

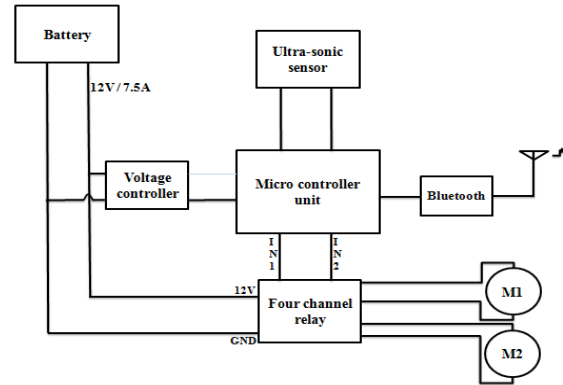

Fig.2 Block Diagram

Frame

The frame is the most important part of the Segway. It is made up of iron angles that form a rectangle of 22”x20”. The platform will be made up of a perforated metal sheet welded to the frame as shown in Fig.1. The motors and the wheels will also be attached to the frame below. The top part of the frame holds the handle bar and the battery container. The handlebar is made of metal bar that is at optimal average height, designed to be held comfortably. The base of the handlebar is firmly attached to the frame and the handlebar freely rotates in one plane about its axis. The battery container is designed to move back and forth to help balance the Segway at Stand by. This helps the user to begin at the neutral axis to the ground that the Segway will stand on. The frame also constitutes a set of small tyres that will be placed at the front end and the back end of the Segway to prevent the user to bend more than the Segway can handle, this adds a safety feature that helps the user to not fall during his commute.



Fig 3. Frame of the SUC, including the handle and wheels

Design & Development of Segway:

The main concern would be the selection of materials, motors, and load bearing members for the proper functioning of the Segway. This mainly involves the selection of motor, selection of wheels and tires, selection of bearings, chains, and sprockets just to name a few

Design Factors for the proposed Segway

Load Capacity : 80 Kgs.

Base Width : 17"

Base Length : 29"

Mast Length : 32"

Types of motion: Forward, Backward, Left, Right

Travel Speed : 5 Km/h

Power Supply : 12V, 7 Ah Pb-Acid Battery

Materials Used For Each Part

Body of the Segway : Wood

Mast : Metal piping Angle

brackets : Mild Steel

Wheels : Nylon Design of Parts Selection of

Driving Motor

$$P = 2\pi NT/60000$$

Where,

P = Power of Motor (KW)

N = Speed (in rpm)

T = Torque (Nm)

T = W x R Where,

W = Total load on wheels = Weight of the operator + weight of the mast + weight of the base + weight of the two motors + weight of the two batteries + weight of the electronics + weight of the wheels

$$= 55+3+22 = 80 \text{ Kgs.}$$

$$= 2\pi NT/60000$$

$$= 2\pi (2750) (0.003 \times 80 \times 9.81)/60000$$

$$P = 0.338 \text{ Kw}$$

i.e. Power of a single motor = 0.338 kW

$$P = 338W$$

III. ELECTRONIC COMPONENTS

The Segway constitutes an electronic system that helps it to operate smoothly. The brain of the Segway is the Arduino Uno motherboard which is shown in Figure. This motherboard is used to process the input and take the required decision accordingly. The Uno board is connected to the batteries, the motor controller and the Android Phone. The Android Phone sends the orientation in real time to the

Arduino and it accordingly sends the required input to the motor controllers which control the motors to turn or accelerate as required. The Android Phone has inbuilt sensors of various kinds. Accelerometer, proximity sensor, GPS, Magnetometer, Heart rate sensor, Light Sensor etc. and all of this information can be forwarded through the multiple output options like Bluetooth, Wi-Fi, Infrared, Audio-Video outputs etc. This can be used to control the Segway, to fine tune it and create unimaginable possibilities with this much information flowing just below the hood. The potential is huge for third party and native applications on the Android platform and the new application genre that will be customized for the Segway alone.

IV. ARDUINO UNO

Microcontroller will act as the brain of the robot. The robot movement will be decided by the microcontroller. In this system we will be using microcontroller named Arduino UNO which contains ATMEGA 328P microcontroller chip (Figure 1). The microcontroller is programmed with the help of the Embedded C programming. Arduino has its own programming burnt in its Read Only Memory (ROM). C program is very easy to implement for programming the Arduino UNO.



Figure 4. Arduino UNO.

Bluetooth Low Energy(BLE):

The Bluetooth module will act as an interface between Smartphone and microcontroller. We will be using BLE Bluetooth module for the system, which can be used as either receiver or transmitter. Generally our transmitter will be smart-phone and receiver will be Bluetooth module (Figure 2).

Bluetooth module will give the commands given by smart-phone to the microcontroller.

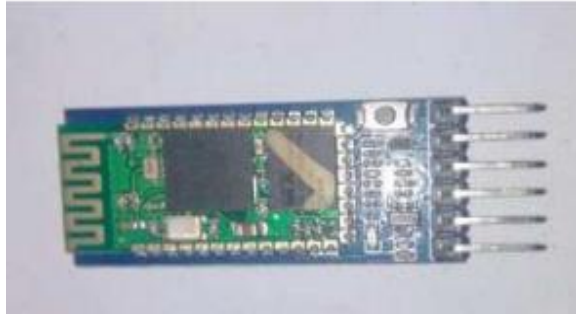

Figure 5. Bluetooth Module.

V. ULTRASONIC SENSOR

The object detection and distance measurement module performs the task of detection of objects and staircases and measures the distance to object/staircase. The detection of objects is at three levels, low level object, waist level object and head level object. The object/staircase detection is done using ultrasonic sensors.



Figure 6. Ultrasonic Sensor

VI. SMART PHONE

The smart phone is the transmitter of this circuit. It sends the data to microcontroller through Bluetooth module. It also helps to send the instruction of forward, backward, left, right to the microcontroller. Actually, the smart phone is used as a remote of this system. Here we the Bluetooth RC Controller application (Figure 3) as the operating remote of this system. The advantage of this project is that the application software designed for android phones is kept simple but attractive with all necessary built-in functions. The novelty lies in the simplicity of the design and functioning.

VII. POWER SOURCE

The Segway is powered by a 12Volt, 42 Ampere Hour battery that is used to power cars is shown in Fig.6. One battery is sufficient enough to take the Segway for a minimum of 2 hours. The battery will be placed on the top side of the frame between the leg space area. It has been given the freedom to move back and forth to help balance the Segway as a whole. There is provision to add another battery in this space if more battery life is required.



Fig. 7. The Lead –Acid battery used in the SUC

VIII. ALGORITHM

- [1] Start
- [2] Acquire the physical parameters using the Inertial Movement Unit.
- [3] Use Complementary Fusion Technique to detect the corresponding change.
- [4] If the robot is leaning, drive the wheels in the direction of the lean.
- [5] If you lean more, go faster.
- [6] If you lean quickly, go faster.
- [7] Turns out to be a control systems problem:
 - a. Input variable is platform angle.
 - b. Output variable is motor speed.
- [8] By controlling the output variable, attempt to keep the input variable zero.
- [9] When lean zero with respect to the original vertical positions, stop driving the wheels.
- [10] Stop

IX. RESULTS

The fabricated Segway was tested on flat platform and it was running smoothly. The load bearing capacity was limited to 80Kg. Thus with the use of Arduino UNO R3 controller all the motions of the Segway was stable.



Figure.8. Fabricated Model

X. APPLICATIONS

1. This personal transporters are becoming more popular as gas prices rise and variety of its uses are found.
2. Helps staff in various roles to travel throughout large bases and vast facilities quickly allows riders to easily travel indoors, outdoors, through doorways and into elevators.
3. Military bases are very large properties which are often home to dozens of buildings. It can take an airman on this device 20 minutes to travel the same distance that would take him 45 minutes to walk. That type of increase in efficiency is valuable.
4. Elevates the visibility, responsiveness and productivity of critical staff.
5. Securities in malls using this vehicle for patrolling is an increasing sight nowadays.

XI. CONCLUSION

Thus we have developed a working model of this self balancing transportation device similar to SEGWAY which is portable and economical using open source microcontrollers and sensors. This project is implemented with an idea to find an effective solution to transportation problem. The main objective is to achieve space utilization and minimize the fuel consumption especially for commuting over shortest distance. Fabricated a Clone Segway of a prototype which clearly demonstrates the advantages of this design for application as a safe and green

personal transport. This design has been thoroughly tested, and all aspects have been taken into consideration. The proposed design may be used for fabrication of a full-scale personal transporter for personal use and is sure to cost much less compared to the original Segway, which costs a fortune in comparison. The vehicle uses electricity to power both of its motors, hence there is zero pollution. The vehicle is able to carry a person easily and with an added luggage too if necessary for the commute for at least two hours. With an added battery pack, we can increase the duration to four or even 8 hours. The vehicle is able to travel for up to 30 kmph, which is more than enough speed for people to commute in. The original Segway is 5, 00,000 INR but the model we've made took only 25,000 INR, hence this allows for easier purchasing at schools and other campuses or even for a common man to commute in.

XII. FUTURE SCOPE

To enhance the functionality and performance of the vehicle there are some areas that could be developed further:

1. Shielding of the steering sensor signal and/or replace the sensor with a less disturbance sensitive sensor.
2. Proper Cushioning of the IMU to reduce the impact of disturbances.
3. Add communication to a web server for logging of data.
4. Bluetooth communication for remote control and remote logging of data.
5. Employing a new remote control mode for the vehicle without rider.

REFERENCES

- [1] M Thompson, J.Beula Julietta Mary, "Design and fabrication of fail safe segway," International Journal of Mechanical and Industrial Technology, vol. 2, no. 1, pp. 767-782, April 2014.
- [2] Sadhana Pai, Jayesh Yadav, Rupesh Ramane, Pooja Pangare, Aniket Paranjpe, "Design of segway personal transporter," International Journal of Advance Foundation And Research In Science & Engineering (IJAFRSE) Volume 1,

Special Issue , Vivruti 2015. Impact Factor:
1.036, Science Central Value: 26.54

- [3] <http://arduino.cc/en/Main/arduinoBoardUno>
- [4] Prof.Yogesh Risodkar ,Mr.Ganesh Shirsath, Ms.Monali Holkar, Mr.Mayur Amle, “Designing the self-balancing platform,” International Journal of Science, Engineering and Technology Research (IJSETR), Volume 4, Issue 9, September 2015.
- [5] <http://en.wikipedia.org/wiki/segway>
- [6] Mikael Arvidsson, Jonas Karlsson, 2012, “Design, construction and verification of self balancing vehicle,” Chalmers University of Technology, Gothenberg, Sweden.
- [7] <http://futureofmechanical.blogspot.in/2012/04/segway-report.html>.
- [8] Nii Adjetey Sowah, 2012, “Dynamic balancing (Segway style),” Project report, Ashesi University College, Ghana.
- [9] M. A. Clark, J. B. Field, S. G. McMahon, P. S. Philps, October 27, 2005, “EDGAR, A Self-Balancing Scooter,” Project report, The University of Adelaide, Australia.