

Solar tracking system

Akash Dubey¹, Sameer Bhamri²

^{1,2}Dept. of Electrical and Electronics Engineering, PSIT Kanpur, Uttar Pradesh, India

Abstract- This paper deals with the efficiency of solar cell with and without tracking system . It also includes a proposed plan of simple dual axis tracking device which is based on servo motors which are in turn interfaced using arduino microcontroller kit . The instructions to the ser- vo motor comes from highly efficient light dependent resistors which are responsible for moment of PV panels towards maximum light intensi- ty.

Index Terms- Arduino Uno, Active and passive trackers, dual and single axis trackers, LDRs, Servo motors, Source code , Circuit diagram.

1. INTRODUCTION

There can be no denying in the fact that solar energy is an effective source of power , one that is going to serve us for long. Despite the need to harness this energy, very little re- search has been conducted to make photovoltaic cells cost ef- fective and thereby available for utilization by masses for their various devices. Photovoltaic cells use sunlight and convert it directly to electricity without leaving any residual elements that can pollute the environs, and is therefore believed to be energy source that could be available to mankind. Besides be- ing used in power generation, photovoltaic cells find applica- tions in other non -space application programs. The ability of solar cells to help produce significant quantities of hydrogen , which has been difficult to produce on a substantial scale till now ,is an encouraging sign as it indicates the possibility that hydrogen could be used as an alternative fuel source in future. Given this scenario, many people wonder why the scientific

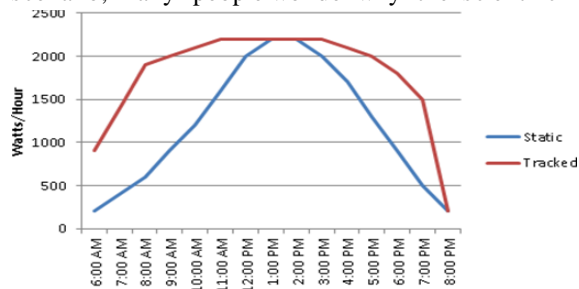

GRAPH 1.1.

Community is not aggressively promoting this naturally and abundantly available energy source. The fact is that the overall picture is not as sunny as it appears on the surface. The eco- nomics of generating solar power is a severe drawback and till date the efficiency levels have been far from satisfactory, till now scientists seem to have maintained the unidirectionality of their research and focused only on single-crystal silicon cells, the efficiency of which is ridiculously low. therefore, research funds , by and large ,have been used for costly and inefficient silicon cells and seem to hold little promise even in the future. Extensive research on non-silicon based cells is the need of the hour as fossil fuels like petrol will be exhausted soon . But what sure holds promising is use of solar tracking systems which has shown us from time to time , improvement in the efficiency speaking statistically. In the case where solar cells are used for conversion of solar energy into electricity, maximum efficiency is possible when solar panels are held perpendicular to the suns rays where tracking comes into picture . Trackers are devices used to change the orientation of the PV panels towards the sun to capture maximum energy . There are many types of trackers available which are prominently divided based on their mounts and drive types which are further discussed below. The graphs below gives a clear comparison about the efficien- cy of solar panel equipped with tracking system to that with- out tracking system.

2. TYPES OF SOLAR TRACKERS BASED ON DRIVE TYPES

A. Passive trackers

The passive solar tracker works on basic thermo hydraulic principles. It consists of two tube tanks attached along the side of the PV panel. The working principle is not as complex as active trackers . When the PV panel is not aligned towards the sun , the fluid(low boiling point compressed gas fluid) inside the tube tank heats up resulting in

formation of uneven pressure within the tube. This pressure allows the fluid to move from one side of the tube to another causing movement of PV panel towards the sun.

On the bright side passive trackers are less expensive and also are less prone to get damaged because of lighting. They might not be as compelling as active trackers but they do offer promising results. But a look at the downside reveals that they tend to be sluggish in morning.

A Fixed solar system **B** Solar tracking system

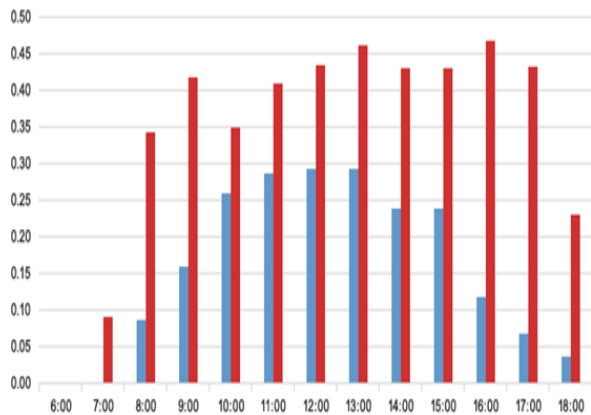

FIG 2. BOOST IN POWER PRODUCTION

4. Tilted single axis tracker, TSAT

5. Vertical single axis trackers, VSAT (which has axis of rotation along vertical axis).

B. Dual axis trackers

Dual axis trackers have two degrees of rotation i.e azimuth rotation (which allows the panel to move in a circular path parallel to the surface) and horizontal rotation, also called elevation angle rotation (which allows the panel to move up and down). The dual axis trackers are able to orient themselves towards the sun so that the panel can be in direct contact of the sun for maximum power generation.

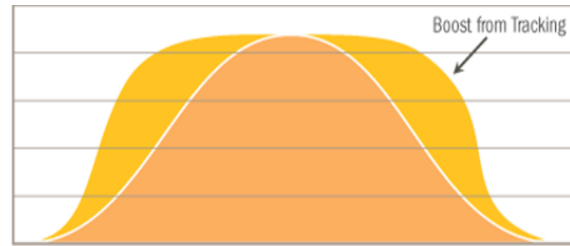

DAILY POWER PRODUCTION TRACKER COMPARED TO FIXED MOUNT
FIG.3. AZIMUTH ANGLE ROTATION

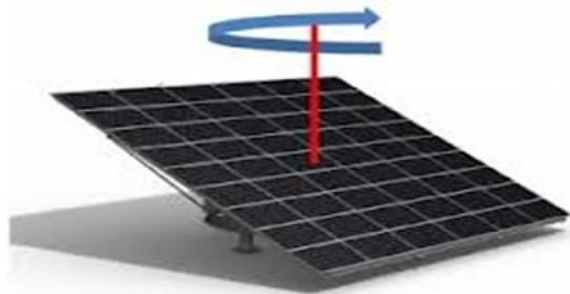

FIG.4 SINGLE AND DUAL AXIS TRACKERS

B. Active trackers

Active trackers are comprised of motor and gear assembly which is controlled by means of controller that responds to the sun's position. Because they consist of motors and moving parts, regular maintenance is required. But they do offer better utilization of solar energy compared to passive trackers.

3. TYPES OF SOLAR TRACKERS BASED ON AXIS

A. Single axis trackers

Single axis solar trackers rotate along one fixed axis. The first solar trackers were single axis trackers and a peek into efficiency reveals that they produce 20 to 25% more electricity as compared with mounted solar panels with no tracker. There are plethora of single axis trackers that are available for tracking purposes based on place and requirements, viz

1. Horizontal single axis trackers, HSAT (which has axis of rotation along horizontal axis).
2. Horizontal single axis tracker with tilted modules, HTSAT (which has axis of rotation along horizontal direction with tilted PV panel).
3. Polar aligned single axis trackers, PSAT (which are aligned along polar direction).

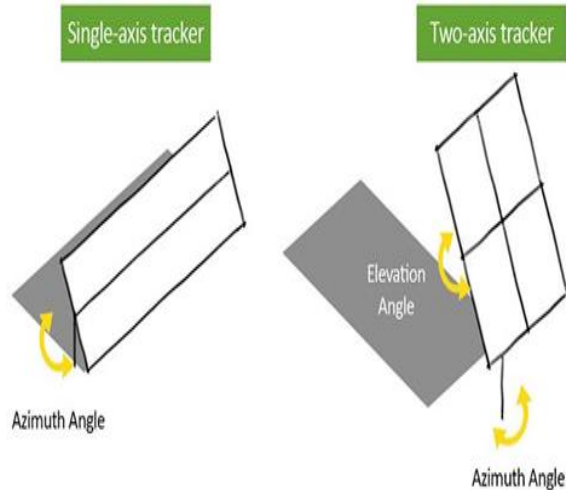

4. DESIGN OF PROPOSED DUAL AXIS SOLAR TRACKER

The proposed plan has to satisfy certain requirements which are as follows

1. It should be reliable under harsh conditions like change in temperature, wind, dust, and humidity.
2. It should consume minimum electricity so that there can be optimum performance to cost ratio.
3. Since solar panels are costly affair, the tracker should give good results with small investment.
4. Taking into account all the parameters the proposed plan to drive the solar panel is based on below mentioned components ;
5. A servo electric motor, light dependent diodes, potentiometers for speed control and tolerance, ATmega328P microprocessor based arduino uno .
6. A measurement system for light intensity applied to the PV panel, representing the sensor that commands the solar panel movement

Light dependent resistors :

Light Dependent Resistor or Photoresistor, which is a passive electronic component, basically a resistor which has a resistance that varies depending of the light intensity. A photoresistor is made of a semiconductor which has high resistance that absorbs photons and based on the quantity and frequency of the absorbed photons the semiconductor material give bound electrons enough energy to jump into the conduction band. The resulting free electrons conduct electricity resulting in lowering resistance of the

photoresistor. The number of electrons is dependent of the photons frequency.

Servo motor :

A servomotor is a rotary actuator or linear actuator that allows for precise control of angular or linear position, velocity and acceleration. It consists of a suitable motor coupled to a sensor for position feedback. It also requires a relatively sophisticated controller, often a dedicated module designed specifically for use with servomotors.

5. COMPONENTS REQUIRED

The components required are as follows ,Arduino uno , servo motors , light dependent resistors , 10K resistors and 10K potentiometers .

Arduino uno : Arduino Uno is a microcontroller board based on the ATmega328P . It has 14 digital I/O pins , 6 analog inputs, a 16 MHz quartz crystal, a USB connection, a power jack, ICSP header and a reset button.

Technical specification:

Microcontroller	ATmega328P
Operating voltage	5V
Input voltage (recommended)	7-12V
Input voltage limit	6-20V
Digital I/O pins	14(of which 6 provide PWM output)
Digital I/O PWM pins	6
Input analog pins	6
Dc current per I/O pin	20mA
Dc current for 3.3V pin	50mA
Flash memory	32KB (ATmega328P) of which 0.5KB used by bootloader
SRAM	2KB (ATmega328P)
EEPROM	1KB (ATmega328P)
Clocks speed	16MHz

6. SOURCE CODE

```

#include <Servo.h> // include Servo library
Servo horizontal; // horizontal servo
int servoh = 90; // stand horizontal servo
Servo vertical; // vertical servo
int servov = 90; // stand vertical servo
// LDR pin connections
// name = analogpin;
int ldrt = 0; //LDR top left int ldrt = 1; //LDR top
right int ldrl = 2; //LDR down left int ldrr = 3; //ldr
down right
void setup()
{
Serial.begin(9600);
// servo connections
// name.attach(pin); horizontal.attach(9);
vertical.attach(10);
}
void loop()
{
int lt = analogRead(ldrt); // top left int rt =
analogRead(ldrr); // top right
int ld = analogRead(ldrl); // down left int rd =
analogRead(ldrr); // down right
int dtme = analogRead(4)/20; // read potentiometers
int tol = analogRead(5)/4;
int avt = (lt + rt) / 2; // average value top
int avd = (ld + rd) / 2; // average value down int avl =
(lt + ld) / 2; // average value left
int avr = (rt + rd) / 2; // average value right
int dvert = avt - avd; // check the diffrence of up and
down int dhoriz = avl - avr; // check the diffrence og
left and right
if (-1*tol > dvert || dvert > tol) // check if the
diffrence is in the tolerance else change vertical
angle
{
if (avt > avd)
{
servov = ++servov; if (servov > 180)
{
servov = 180;
}
}
else if (avt < avd)
delay(dtme);
}
}

```

7. CIRCUIT DIAGRAM

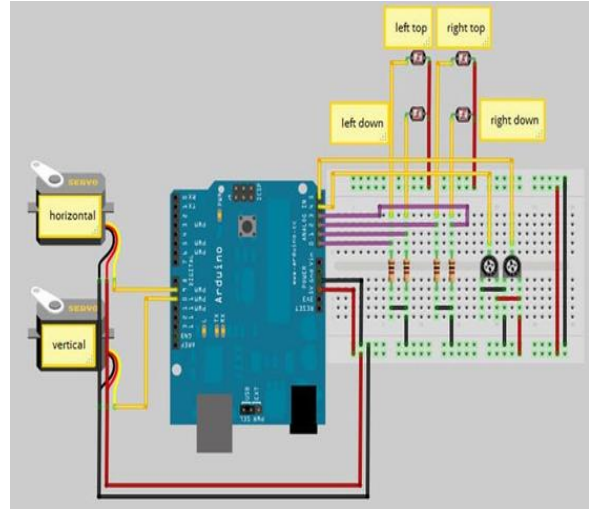

8. ADVANTAGES

- [1] Solar trackers are highly efficient installations. The operating costs are extremely low once the initial investment of building a solar power plant has been spent.
- [2] As solar tracker is directly exposed to solar rays, they can generate more electricity compared to their stationary counterparts.
- [3] Solar trackers continuously direct photovoltaic panels towards the sun, maximizing the investment on photovoltaic systems.
- [4] Roughly, in the same amount of space needed for fixed tilt systems if solar trackers are installed, solar trackers can generate more electricity making way for ideal usage of land.
- [5] Solar trackers can be utilized most efficiently in areas with low horizons and locations which are shade free from daybreak to dusk every day.
- [6] Depending on degree of latitude, installation size, local weather and electrical requirements, there are many different kinds of solar trackers available such as single axis, dual axis trackers which can perfectly fit as per the required conditions.

9. CONCLUSION

The paper gives a brief overview of solar tracking system based on microcontroller and also describes about the simple and attractive features of tracking system. This solar tracker operation costs and maintenance cost are comparatively low. Here the use of stepper motors in solar trackers enables accurate

tracking of the sun and light dependent resistor are used to determine the solar light intensity. The paper concludes that solar tracking system provides more effective method to track the solar insolation and provide economic consistency for generation of electric power. Solar power technology is constantly advancing and improvements will intensify in future.

REFERENCES

- [1] <https://www.arduino.cc/en/Main/arduinoBoardUno>
- [2] Tiberiu Tudorache, Liviu Kreindler - Technosoft, 266-268 Calea Rahovei, Sect. 5
- [3] J. A. Beltran, J. L. S. Gonzalez Rubio, C.D. Garcia-Beltran: Design, Manufacturing and Performance Test of a Solar Tracker Made by an Embedded Control, CERMA 2007, Mexico
- [4] M. A. Panait, T. Tudorache: A Simple Neural Network Solar Tracker for Optimizing Conversion Efficiency in Off-Grid Solar Generators, ICREPQ 2008, Spain
- [5] "Portable solar trackers", Moser, LLC