

Design of Maximum Power Point Tracking (MPPT) Technique Based On Swarm Intelligence Algorithms

Rachuri srinivasulu¹, Mruthyunjaya Reddy²

¹M.Tech., PG Scholar, Akshaya Bharathi Institute of Technology, R.S. Nagar, Siddavatam, Kadapa

²Assistant Professor, Dept of EEE, Akshaya Bharathi Institute of Technology, R.S. Nagar, Siddavatam, Kadapa

Abstract- Main objective of this paper is to develop an intelligent and efficient Maximum Power Point Tracking (MPPT) technique. Most recently introduced of intelligent based algorithm Cuckoo search algorithm has been used in this study to develop a novel technique to track the Maximum Power Point (MPP) of a solar cell module. The performances of this algorithm has been compared with other evolutionary soft computing techniques like FA and PSO. Simulations were done in MATLAB/SIMULINK environment and simulation results show that proposed approach can obtain MPP to a good precision under different solar irradiance and environmental temperatures.

Index Terms- Maximum Power Point Tracking (MPPT), Cuckoo Search (CS) Algorithm, Firefly Algorithm (FA), Particle Swarm Optimization (PSO), Photovoltaic cell.

I. INTRODUCTION

On-site generation (OSG) constitute a major part of power delivery systems (PDS). With the increasing demand for power, the On-site generation systems play a vital role in providing continuous supply of power. Photovoltaic (PV) energy becomes an important alternative as it is ubiquitous, environment friendly, freely available, and has low operational and maintenance costs [1]. Over the past few years, many researches committed their works to increase the efficiency of a solar cell and to make solar energy cheap for practical uses. In this point of view it is covet to operate the PV module at the Maximum Power Point (MPP) to extract maximum power from it. Various literatures have been studied [1]-[4], for the MPPT in PV systems. Recently developed swarm intelligence optimization technique which is inspired from the social behavior of various species like ants, fireflies, honey bees, termites. There are many methods for determining the maximum power point

of a solar cell. These methods can be differentiated based on their characteristics towards PV module:

1. Direct method- the instantaneous values of current and voltage are varied in order to reach the maximum power point. This direct method drawback can be overcome by using artificial intelligence.
2. Artificial intelligence - This method directly depends upon the solar cell model. They are based on the evolutionary biology and swarm intelligence algorithms. These algorithms generate duty cycle for operating point of PV module, by the change in external parameters.

In this paper it is proposed a soft computing technique based on Intelligence optimization technique to track the Maximum Power Point of a solar cell. We concentrated our focus on most recently introduced nature-inspired metaheuristic based [5] algorithm Cuckoo Search (CS). Cuckoo Search Algorithm (CSA) is inspired by obligate brood parasitism of some cuckoo species which lay their eggs in the nest of some other host bird species. On the other hand Artificial Bee Colony is inspired from the intelligent exploration for food sources of honey bees and Firefly Algorithm simulates the social behavior of tropical fireflies and is based upon their characteristic flashing pattern. On the other hand Particle Swarm Optimization (PSO) is population-based evolutionary search algorithm (EA) method, modeled after the behavior of a flock of birds.

In conventional methods MPPT was achieved by using P&O, IC but it has the disadvantages of longer convergence time and failed to track GMPP which produces oscillations of power output around the MPPT even under steady state illumination. The IC also produces the oscillations and can perform erratically under rapidly changing atmospheric conditions. By combining P&O and IC algorithms for

MPPT are prone to failure in case of large changes in irradiance.

To overcome the difficulties in conventional methods, this work proposes the best performance of MPPT using soft computing oscillations and obtain MPPT to a good precision under different solar irradiance and environmental temperatures. The work will be carried out in MATLAB/SIMULINK environment.

II EQUIVALENT CIRCUIT MODEL OF A PHOTOVOLTAIC CELL

A solar cell can be modeled by the equivalent circuit shown in fig 1. An ideal solar cell can be modeled using a constant current source and a diode in parallel. But in practical cases, there are series and parallel resistors associated with the PV module which imply non-ideal characteristics. The series resistor indicates the internal resistance and the parallel resistors associated with a leakage current (I_{sh})

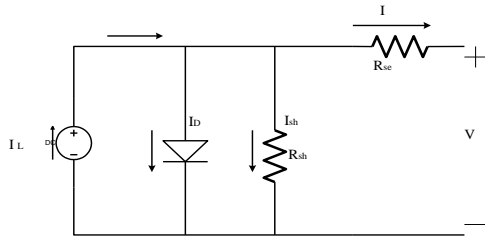

Fig. 1 Equivalent circuit model of solar cell

I-V characteristic equation of a solar cell can be easily deduced from the above equivalent circuit of a solar cell. It can be written as:

$$I = I_L - \left(e^{\frac{v+R_s I}{\eta V_t}} - 1 \right) - \left(\frac{V + R_s I}{R_{sh}} \right) \quad (1)$$

$$P = V * \left(I_L - \left(e^{\frac{v+R_s I}{\eta V_t}} - 1 \right) - \left(\frac{V + R_s I}{R_{sh}} \right) \right) \quad (2)$$

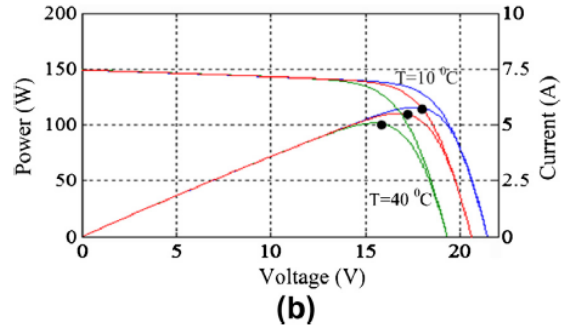
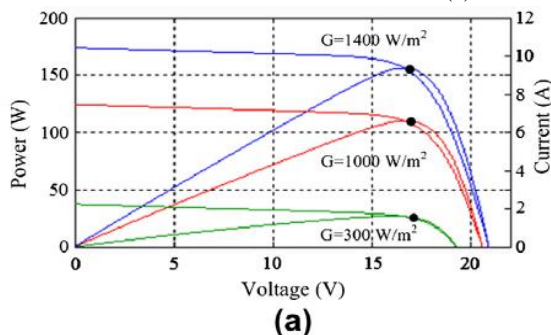

Fig.2 The I-V and P-V curves of the PV module under varying (a) solar irradiance and (b) under varying temperature.

In (1) I and V are output current and voltage from the solar cell. R_s and R_{sh} are series and parallel resistances associated with the solar cell. From this equation it can be observed that the output current of a solar cell is a function of I_L and environmental temperature. η is the ideality factor of the P-N junction. The above model was realized and effects of the parameters (irradiance level and temperature) on the P-V characteristics were observed.

III. METAHEURISTICS OPTIMIZATION METHODS FOR MPPT

Maximum Power Point Tracking, usually referred as MPPT, is an electronic system that allows the Photovoltaic (PV) modules to operate in a manner to produce all the power they are capable of producing. From Maximum Power Transfer theorem, the power output from a circuit is maximum when the load impedance of the circuit matches with the source impedance. Hence MPPT problem is impedance matching problem. By using Maximum power point tracking technique efficiency of the solar panel is ameliorated. During day time the irradiance on a PV panel and its operating temperature changes. PV module output power is dependent on the insolation. P-V characteristics can vary with insolation and temperature.

For conventional MPPT, the methods include incremental conductance, hill climbing, perturb and observe, short circuit current, open circuit voltage, ripple correlation control and current sweep method. These methods are satisfied under uniform solar irradiance conditions. In normal condition, it is able to track efficiently, but continuous oscillations occur around MPP, loss of power in a steady state

condition. These techniques are failing to track global maximum power point (GMPP) and cannot capable of handling partial shading conditions. In soft computing method, the methods such as artificial neural network, fuzzy logic controller, Ant-colony optimization, and particle swarm optimization and differential evolution. Recent approaches in software computing methods are Artificial Bee Colony, cuckoo search and firefly algorithm. Comparing with conventional MPPT, soft computing method able to track the GMPP in multiple peaks.

In this paper we concentrate our focus on four popular soft computing intelligence based algorithms: Particle Swarm Optimization (PSO), Firefly Algorithm (FA), Artificial Bee Colony (ABC) Algorithm and Cuckoo Search (CS) Algorithm.

A. Particle Swarm Optimization

Particle swarm of optimization (PSO) is a stochastic, population-based evolutionary search algorithm (EA) method, modeled after the behavior of a flock of birds [6]. The PSO algorithm maintains individual swarms (called particles), where each particle represents a candidate solution. Particles follow a simple behavior: emulate the success of neighboring particles and its own achieved successes.

The position of a particle is, therefore, influenced by the best particle in a neighborhood P_{best} as well as the best solution found by all the particles in the entire population G_{best} . Movement of particles in the optimization process using

$$x_i^{k+1} = x_i^k + \phi_i^{k+1} \quad (3)$$

Where, the velocity component ϕ_i represents the step size. The velocity is calculated by

$$\phi_i^{k+1} = w\phi_i^k + c_1r_1\{P_{best_i} - x_i^k\} + c_2r_2\{G_{best} - x_i^k\} \quad (4)$$

Where w is the inertia weight, c_1 and c_2 are the acceleration coefficients, $r_1, r_2 \in U(0, 1)$, P_{best_i} is the personal best position of particle i , and G_{best} is the best position of the particles in the entire population. If position is defined as the actual duty cycle while velocity shows the disturbance in the present duty cycle, then (3) can be rewritten as

$$d_i^{k+1} = d_i^k + \phi_i^{k+1} \quad (5)$$

However, for the case of PSO, resulting disturbance in the present duty cycle depends On P_{best_i} and G_{best} . If the present duty cycle is far from these two

duty cycles, the resulting change in the duty cycle will also be large, and vice versa. Therefore, PSO can be thought of as an adaptive form of HC. In the latter, the perturbation in the duty cycle is always fixed but in PSO it varies according to the position of the particles. With proper choice of control parameters, a suitable MPPT controller using PSO can be easily designed. This method suffers from the partial optimization, which degrades the regulation of its speed & direction. Problems with non-coordinate systems & PSO functioning only one objective function at a time.

B. Firefly Algorithm

The Firefly Algorithm is a metaheuristic, stochastic search algorithm which is inspired from the tropical firefly's social behavior [7]. They interact with each other through varying flashing patterns that uses bioluminescence. The rate of flashing, intensity and rhythm of flashes creates a pattern which attracts both the females and males to each other. Another important function is potential prey is attracted by flashing. The fireflies flashing characteristics can be summarized by following rules:

1. Fireflies are unisex. Hence regardless of sex every firefly will move towards more attractive one.
2. The attractiveness of one firefly is proportional to its flashing intensity, Thus for two flashing fireflies less bright will move towards the brighter one. If there are no brighter fireflies than it the firefly will move randomly through the space.
3. Attractiveness will decrease as the intensity of the light decreases with distance.
4. The flashing intensity of a particular firefly concurs with the fitness value of the objective function to be optimized.
5. Thus there are two important factors involved for firefly algorithm: formulation of attractiveness and variation of light intensity. It is evident that if distance from the source increases accordingly light intensity varies.

In simplest cases light intensity varies according to light absorbing coefficient and inverse square law, which provide the following Gaussian form:

$$I(r) = I_0 e^{-\gamma r^2} \quad (6)$$

Here I_0 is the intensity at the source. Depending on the medium properties Light intensity also varies. For a medium having light absorbing coefficient γ . Firefly's attractiveness is proportional to the light intensity seen by the adjacent fireflies. So, if we define attractiveness variable as β it will be quite similar to the variation in light intensity.

$$\beta = \beta_0 e^{-\gamma r^2} \quad (7)$$

Here β_0 is the attractiveness at $r=0$ and r is the adjacent distance between two fireflies. The case $r=0$ implies two fireflies were found at the same exact point on the search space. The value of light absorbing coefficient γ plays a critical role on the performance of the speed of convergence and the algorithm. In most of the practical optimization problems the value of γ we assumed to be between 0.1 and 10. The distance between two fireflies can be computed as the Cartesian distance B between them. For example, the distance between i^{th} and j^{th} fireflies can be given as:

$$r_{ij} = |x_i - x_j| = \sqrt{\sum_{k=1}^d (x_{ik} - x_{jk})^2} \quad (8)$$

The main position update formula for i^{th} firefly which is attracted to another more attractive (brighter) firefly j can be given as:

$$x_i^{t+1} = x_i^t + \beta_0 e^{-\gamma r_{ij}^2} (x_j - x_i) + \alpha \epsilon_i \quad (9)$$

Here randomization parameter is ϵ_i . It is a vector of random numbers being drawn from Gaussian or other distribution. And α is the parameter controlling the step size. In some variants of Firefly Algorithm, the movement of the fireflies is gradually decreased by controlling the parameter α . It has some disadvantage such as getting trapped into several local optima. FA parameters are set fixed & they do not change with the time. In addition FA does not memorize or remember any history of better situation for each firefly & this causes to move regardless of its previous better situation.

C. Cuckoo Search Algorithm

Cuckoo Search Algorithm (CSA) is one among such nature inspired optimization algorithms developed by scientists Xin-She Yang and Suash Deb in the year 2009. It was inspired by obligate brood parasitism of

some cuckoo species which lay their eggs in the nest of some other host bird species and manipulates the host bird to raise their young ones. Specific egg laying and breeding of cuckoos by the host bird forms the basis of this optimization algorithm. Cuckoos used in this optimization method exist in two forms as mature cuckoos and eggs. Mature cuckoos lay eggs in the host bird's nests and if these eggs are not recognized or killed by host birds, they grow into a mature cuckoo. Environmental features and the immigration of societies of cuckoos help them to converge and find the best habitat for breeding and reproduction. This best habitat is the global maximum of objective function [11].

Cuckoos are fascinating birds because of the beautiful sounds they can make and also because of their reproduction adaptation to continue their generations. Some species such as the ani and Guira cuckoos lay their eggs in communal nests and remove others' in order to increase the chance of hatching of their eggs in communal nests. Some species undertakes the obligate brood parasitism by laying their eggs in the nests of other host bird species in which the host cannot find any difference between the eggs present in nest. There are three basic types of brood parasitism: intraspecific brood parasitism, cooperative breeding, and nest takeover. Some host birds engage direct conflict with the intruding cuckoos. If a host bird discovers the cuckoo eggs it will throw these alien eggs away or abandons its nest and builds a new nest elsewhere. Some cuckoo species have evolved in such a way that female parasitic cuckoos mimic colour and pattern of the eggs of a few chosen host species. This increases the probability of egg hatching, thus increasing their chances to reproduce next generation.

(i). Levy Flights:

Searching for a suitable host bird's nest is an important part of cuckoo's reproductive adaptation. Normally, the search for the nest is similar to the search for food, which takes place in a random or a quasi-random form. In general, while searching for food and mate, animals choose directions of path or trajectories that can be modelled by certain mathematical functions. One of most common model is the Levy flight. A Levy Flight can be understood as a random walk where the step size has a Levy probability distribution. In CS, nest searching is

characterized by Levy flight. Mathematically, a Levy flight is a random walk where step sizes are extracted from Levy distribution according to a power law [12] as shown below:

$$Levy(\lambda) \approx u \approx l^{-\lambda}, (1 < \lambda < 3) \quad (13)$$

Where l is the flight length and λ is the variance. Since $1 < \lambda < 3$, y has an infinite variance. Due to the virtue of Levy distribution, the steps consist of many small steps and also large-step, long distance jumps. Comparing to other metaheuristic algorithms, these long jumps may increase the search efficiency of cuckoo search significantly especially for multimodal, nonlinear problems.

(ii). Cuckoo Search via Levy Flights

Three idealized rules for CS based on cuckoo's brood parasitic behavior: (1) Each cuckoo lays one egg at a time and laces it in a randomly chosen nest (2) The best nest with the highest quality of eggs will be carried over to the next generation (3) The number of available nests is fixed and the number of cuckoo eggs discovered by the host bird maintains a probability P_a , where $0 < P_a < 1$ [9]. For maximization problems, the fitness of a solution can be proportional to the value of the objective function. For simplicity, we can use the following representations that each egg in a nest represents a solution, and a cuckoo egg represents a new solution. Our aim is to use the new and potentially better solutions (i.e. Cuckoos) to replace a not-so-good solution in the nests. When generating a new solution for a cuckoo, a Levy flight is performed as in the following expression:

$$x_i^{k+1} = x_i^t + \alpha \oplus Levy(\lambda) \quad (14)$$

Where \mathbf{X}_i^t is samples/eggs, i is the sample number, t is the number of iteration and α is the step size, which is related to the scales of the problem of interests. In most cases, we can use $\alpha = 1$. A random walk is a Markov chain whose next location depends only on the current location (the first term in the above equation) and the transition probability (the second term). The product \oplus means entry wise multiplications. In most cases α is used as in the following equation, i.e.

$$\alpha = \alpha_0 (x_j^{(t)} - x_i^{(t)}) \quad (15)$$

Where α_i is the initial step change. In this equation, the difference between two samples is used to determine the subsequent step size. An important advantage of this algorithm is its simplicity and uniqueness. The applications of Cuckoo Search in engineering optimization problems have shown its promising efficiency. Some of Applications are spring design and welded beam design problems, Design optimization of truss structures, Engineering optimization Steel frames, Wind turbine blade and Stability analysis.

IV. INTELLIGENCE BASED MPP TRACKING

In this section we propose an intelligent approach to track the Maximum Power Point (MPP) of a solar cell. The intelligence based algorithms are used to track global MPP of a PV module. The main objective of the proposed model is to deliver a constant power, which corresponds to P_{max} of the solar cell at that given irradiance level and temperature. The most important function of the Intelligent based controller is to take output voltage and current of the PV module as input and compute a duty cycle corresponding to the peak power at the particular G and temperature in which the PV module is operating. Then this duty cycle is fed to a boost type dc-dc converter which delivers the desired constant power to the load. A simple schematic of the proposed approach is given in the fig.3.

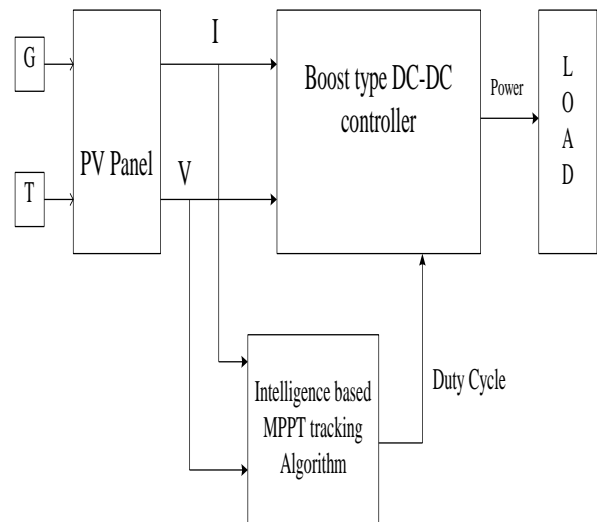

Fig.3 Schematic representation of the proposed approach

V. RESULTS AND DISCUSSIONS

The model described in section IV was realized in Matlab/Simulink environment. Cuckoo Search (CS), Artificial Bee Colony (ABC), Firefly Algorithm (FA) and Particle Swarm Optimization (PSO) were separately used in the model. Simulation for each case has been given. Table 2 demonstrates MPP for a given solar cell at different irradiance levels and temperature found by Simulink model described in section IV. Parameters of REC-AE220 PV module under standard test condition [12] is selected for this purpose which are given in table I. Fig 7 demonstrates the controller output at 500 W/m²&25°c when using CS as MPPT tracking algorithm. Fig 4, 5, 6 demonstrates the controller output at same condition when PSO,FA and ABC respectively was used as MPPT tracking algorithm. Table 1: Model parameters of rec-ae220 PV module under STC

I_s	1.6×10^{-10} A
I_{ph}	8.206 A
R_s	0.47 Ω
R_{sh}	608 Ω
No. of cells in series per module	60

Table 2: Comparison of performances of different evolutionary algorithms

Operating condition		Power delivered to the load		
		CS	FA	PSO
100 w/m ²	15°c	22.59	21.67	21.53
	25°c	22.09	21.20	21.06
	35°c	21.61	20.73	20.06
	45°c	21.13	20.27	20.14
300 w/m ²	15°c	72.50	71.35	70.15
	25°c	71.79	70.66	69.47
	35°c	71.09	69.97	68.79
	45°c	70.40	69.28	68.12
500 w/m ²	15°c	126.0	122.8	122.6
	25°c	125.4	122.2	121.9
	35°c	124.7	121.5	121.3
	45°c	124.1	120.9	120.7
1000 w/m ²	15°c	259.6	256.3	254.6
	25°c	259.6	256.3	254.5
	35°c	259.5	256.2	254.5
	45°c	259.4	256.2	254.4

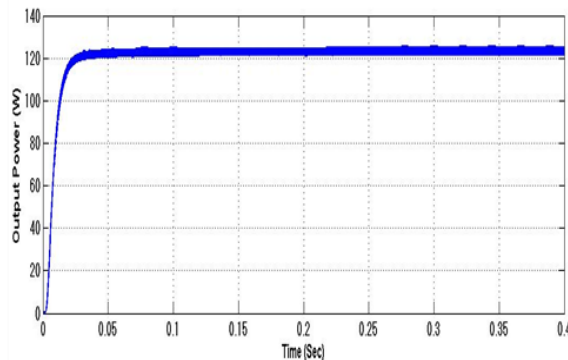

Fig. 4 Controller output at 500 w/m² & 25°c using PSO as MPPT tracking Algorithm

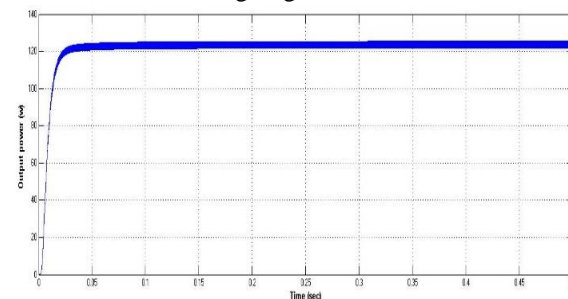

Fig.5 Controller output at 500 w/m² & 25°c using FA as MPPT tracking Algorithm

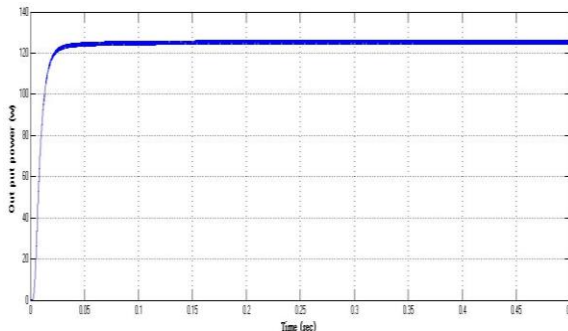

Fig. 6 Controller output at 500 w/m² & 25°c using CS as MPPT tracking Algorithm

VI. CONCLUSIONS

Soft computing intelligence is most popularity among researchers for its fast convergence rate that is also a necessary criterion for tracking Maximum Power Point (MPP) of a solar cell. Hence in this paper, we opted for different soft computing intelligence based optimization technique to track MPP of a solar cell. Also data given in table 3 suggest that the powers delivered to the load at different irradiance levels and temperatures are the Maximum Power Point of the solar cell for different soft computing techniques. The controller outputs given in fig. 7 suggest that

there has been almost zero steady state oscillation when Cuckoo Search (CS) are used as MPP tracking algorithm and also other algorithm also get a zero steady state oscillations, But in CS method we get maximum power delivered to the load at the same conditions. In [13], the authors showed the metaheuristic evolutionary computing techniques like ABC, FA and PSO are competent in the field of Maximum Power Point Tracking of a solar cell. In this paper we used those algorithms also in our simulation model. From our results it may be concluded that CS tracks MPP at a much faster rate than those algorithms. So, an important advantage of this algorithm is its simplicity and uniqueness. Compared to other metaheuristic algorithms such as particle swarm optimization and harmony search, there is essentially only a single parameter in Cuckoo Search (apart from the population size n). Therefore, it is very easy to implement. It gives better performance and fast convergence tracking speed, Cuckoo search is particularly suitable to track GMPP for partial shading conditions [14]. Faster response of the controller and efficient power delivery to load prove the validity of our work. The model is also versatile enough so that it can be used in case of multiple array of solar cells in future works.

REFERENCES

- [1] W. Xiao, N. Ozog, and W. G. Dunford, "Topology study of Photovoltaic interface for maximum power point tracking," *IEEE Trans. Ind. Electron.*, Vol. 54, No. 3, (2007), pp. 1696-1704.
- [2] E. Koutroulis, K. Kalaitzakis, and N. C. Voulgaris, "Development of a Microcontroller-based photovoltaic maximum power point tracking control System," *IEEE Trans. Power Electron.*, Vol. 16, No. 1, (2001), pp. 46-54.
- [3] N. Femia, G. Petrone, G. Spagnuolo, and M. Vitelli, "Optimization of Perturb and observe maximum power point tracking method," *IEEE Trans. Power Electron.* Vol. 20, No. 4 (2005), pp. 963-973.
- [4] I. William Christopher and R. Ramesh, "Comparative Study of P&O and InC MPPT Algorithms", *American Journal of Engineering Research (AJER)*, e-ISSN : 2320-0847 p-ISSN : 2320-0936, Volume-02, Issue-12, pp-402-408.
- [5] X. S. Yang, "Nature-inspired Metaheuristic Algorithm", *Luniver Press.* (2008).
- [6] R. Eberhart and J. Kennedy, "A new optimizer using particle swarm theory," in *Proc. 6th Int. Symp. Micro Mach. Human Sci.*, 1995, pp. 39-43.
- [7] Xin-She Yang, "Chaos-Enhanced Firefly Algorithm with Automatic Parameter Tuning," *International Journal of Swarm Intelligence Research*, December 2011.
- [8] D. Karaboga, "An idea based on honey bee swarm for numerical optimization", *Technical Report-TR06*, Erciyes University, Engineering Faculty, Computer Engineering Department, 2005.
- [9] D. Karaboga, B. Akay, "A comparative study of artificial bee colony algorithm", *Applied Mathematics and Computation*, In Press, 2009.
- [10] D. Karaboga, B. Basturk, "A powerful and efficient algorithm for numerical function optimization: artificial bee colony (ABC) algorithm," *Journal of Global Optimization* 39 (2007) 171-459.
- [11] Ramin Rajabioun, "Cuckoo Optimization Algorithm", *Applied Soft Computing*, 2011.
- [12] Farivar, G.; Asaei, B.; Mehrmami, S., "An Analytical Solution for Tracking Photovoltaic Module MPP," *Photovoltaics*, *IEEE Journal of*, vol. 3, no. 3, pp. 1053, 1061, July 2013.
- [13] Zainal Salam, Jubaer Ahmed, Benny S. Merugu, "The application of soft computing methods for MPPT of PV system: A technological and status review", *Applied Energy*, vol. 107, pp. 135-148, July 2013.
- [14] Xin-She Yang, Suash Deb, "Cuckoo Search via Levy Flights" *World Congress on Nature & Biologically Inspired Computing (NaBIC 2009)*, 2009.