

A Power Efficient Low input 12nm FinFET Level Shifter for near threshold circuits

Radhika¹, Dr. Jayadeva T²

¹Student, Dayananda Sagar College of engineering, Bangalore

²Asst. prof, Dayananda Sagar College of engineering, Bangalore

Abstract- Power has transformed into the basic arrangement plan for chip designers today. While Moore's law sustains to give extra transistors, power related requirements have begun to block those devices from being used. Nowadays, low power outlines, especially multi-voltage designs transform into a notable and capable way to deal with decrease in both dynamic power and static power utilization. A key parameter in outlining of powerful multi supply circuits is restricting the cost of the level change between different voltage spaces while keeping up the general strength of the design. To such a reason, level shifter (LS) circuits can be utilized. So as to accomplish lessening in power utilization, a proposed level shifter topology has been used as a part of this paper which utilizes a low dispute amongst PMOS and NMOS transistor because of which dynamic vitality utilization is decreased, speed is likewise expanded because of the utilization of criticism circle and furthermore because of the close limit figuring its vitality productivity is more. As 12nm innovation node conveys better thickness and an execution help over Global Foundries' present age 14nm FinFET, which fulfills the handling needs of the most requesting computer intensive applications from artificial intelligence and virtual reality to top of the line advanced cells and systems administration foundation, the proposed level shifter has been downsized to 12nm innovation node which is equipped for changing over close limit voltage level to above edge voltage signal (i.e. from 250mV to 500mV) with 284.1229nW of power dissipation.

Index Terms- 12nm FinFET's, level shifter, low power, near threshold circuits.

I. INTRODUCTION

With the creating enthusiasm of handheld contraptions like cell phones, blended media devices, individual notepads etc., low power utilization has ended up being essential design thought for VLSI circuits and frameworks. Power consumption in

VLSI circuit involves dynamic and static power consumption [8]. Dynamic power has two sections i.e. exchanging power due to the charging and discharging of the load capacitance and the short circuit power as a result of non-zero rise and fall time of the input waveforms[8]. The static energy of CMOS circuits is controlled by the leakage current through every transistor. Power utilization of VLSI circuits can be lessened by scaling supply voltage and capacitance. With the diminishing in supply voltage, issues of little voltage swing, leakage current and so forth starts. With the progression of development towards submicron region leakage power has ended up being vital piece of total power dissipation. Static power part of energy utilization must be given due idea if current examples of scaling of size and voltage supply ought to be maintained.

Manufacture of various components like analog, digital, passive component is done on a solitary chip in a framework on chip (SoC) design which needs unique voltages with a specific end goal to accomplish an ideal execution. The level shifters are adjusted to change over the rationale level or voltage starting with one voltage level then onto the next and frame the most considerable circuit part in VLSI frameworks. Level shifters are essentially utilized as a part of some multi voltage frameworks and can be used in the middle of center circuits and I/O circuit.

Starting at now, sundry level shifter plans have been proposed as of late. In a general sense the level shifter circuits can be predicated on following three methodologies: (i) Differential course voltage switch (DCVS) level shifter, (ii) Wilson current mirror[3]-[4] and (iii) A particular circuit topology utilized as a part of [2].

A Differential cascode voltage switch (DCVS) rationale is a CMOS circuit system which has potential focal points over traditional NAND/NOR

rationale as far as circuit delay, format thickness, power dissemination, and rationale flexibility[9].

The primary focal point of this brief is to have a power effective level shifter topology which works over a wide voltage go and braces voltages extending from a low voltage VDDL close to the edge voltage i.e approx. 250mV to a high voltage VDDH i.e approx. 500mV.

A circuit topology of proposed level shifter from [1] has been downsized to 12nm in this brief and has been recreated in Cadence virtuoso with Specter Simulator for checking the level moving of voltage from VDDL to VDDH.

The paper takes after as: In area II, a succinct elucidation of the circuit topology took after by causing the image of the same at 12nm Channel Length of the FinFET has been portrayed in segment III. Afterward, in segment IV the recreation aftereffect of the same has been advised.

II. PROPOSED WIDE VOLTAGE RANGE LEVEL SHIFTER FOR NEAR THRESHOLD CIRCUITS

The proposed level shifter is predicated on DCVS, homogeneous to the standard level moving circuit portrayed in Section II. Rather than increasing the span of the NMOS transistors, nonetheless, the proposed circuit progressively transmutes the current sourced by the applicable PMOS pull-up transistor (PL/PR) to discover that the feeble NMOS pull-down transistor (NL/NR) sinks more current than the PMOS pull-up (PL/PR) organize sources. The proposed low voltage level shifter is as showed up in Fig. 1.

A. Structure of the Proposed Wide Voltage Range Level Shifter.

The peculiarity of this circuit topology is the criticism circle. The criticism circle includes a postpone component that partners the output node D (high voltage area) to the contribution of two multiplexers, MUXL and MUXR. The defer component is predicated on two slightest estimated serially associated inverters. These inverters are given a high voltage (500 mV) and get a high voltage flag D as an information. This postpone component does not impact the deferral of the proposed level shifter, since the postpone component is inside the criticism circle that sets up the circuit for the

following progress. The MUXs are predicated on two arrangements of pass doors, as appeared in Fig. 1. The output of MUXL (high voltage space) is associated with the door of the PMOS pull-up transistor PL. Exactly when select is (high voltage space), the door of PL is associated with the moderate voltage Vddm, which vaporously drains PL[1]. Exactly when select is low, the entryway of PL is associated with node D, which protects the differential activity. Similarly, the output of MUXR is associated with the door of the PMOS pull-up transistor PR. Right when select is high, the door of PR is associated with node D, which safeguards the differential activity. Right when select is low, the door of PR is associated with the middle voltage Vddm, which vaporously undermines PR. An instance of this action is depicted in Section III-B.

This courses of action disposes of the purpose for the monstrously enormous NMOS pull-down transistors, NL and NR, in light of the fact that the fitting PMOS pull-up transistor is kept up at a low voltage predisposition for the forthcoming change. This approach withal uncommonly cuts down the change time as contrasted and other level shifters.

Symmetric movement of the proposed level shifter is protected over the outrageous working reach. Only a minor changing of the differential branches and the info inverter is required because of the low question between the draw up PMOS transistors and the draw down NMOS transistors. In the midst of the falling change, the information flag multiplies through a skewed inverter with a more extensive PMOS transistor to confine the charge time of the NL door. Node D is released with low clash from PL, which quickly turns on PR (as opposed to a standard high debate level shifter) to charge the output. Of course, the raising information incites a more speedy progress, since the hoisting input does not have a reversal delay.

This reversal delay is connected in the midst of the raising change by measuring NR more moment than NL (to take care of symmetry). Symmetric undertaking of the proposed level shifter is indicated by and large while working proximate to the outrageous voltage extend. With more modest voltage ranges (e.g., 0.5 to 0.79 V and less), the symmetry corrupts. The low clash between PMOS what's more, NMOS transistors furthermore adds to the higher dynamic essentialness proficiency of the

proposed circuit as contrasted and the other level shifters.

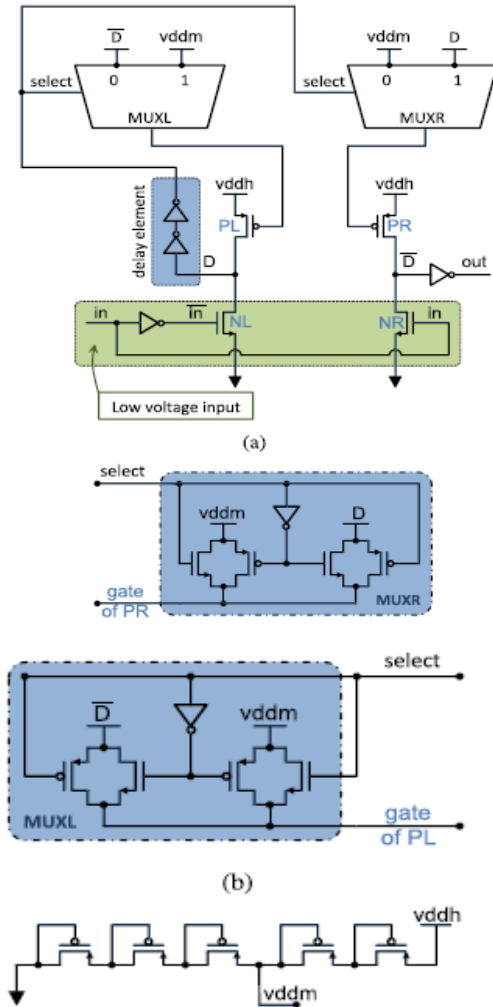

Fig. 1. Structure of the proposed wide voltage range level shifter, including (a) level shifter circuit, (b) internal MUX structures, and (c) intermediate voltage generator.

The intermediate voltage V_{ddm} is incited by a voltage divider, as appeared in Fig. 1, which contains five slightest measured diode associated PMOS transistors. In this setup, a steady partialness voltage of 350 mV is caused to cripple, as required, the draw up PMOS transistors.

The territory overhead is commensurable with the reference level shifters in light of the more moment zone of the draw down NMOS transistors. While the addition of the MUXs, delay components, and middle of the road voltage engenderer presents supplemental transistors, this region is much the same as the

territory required by the more unpredictable draw up system of the reference level shifters.

As portrayed in this segment, the proposed level shifter shows higher execution as contrasted and the other level shifters.

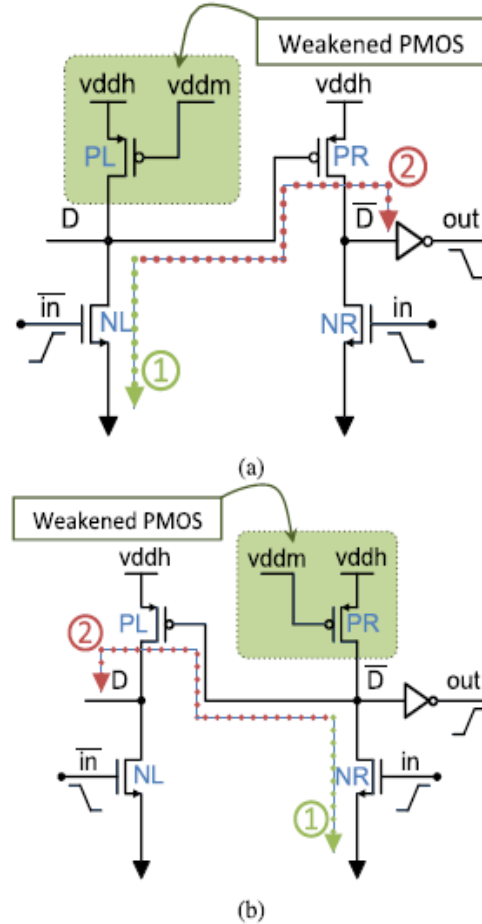

Fig. 2. Operation of proposed level shifter when (a) output is high and the next transition is falling, and (b) output is low and the next transition is rising.

The scurry improvement is because of the input circle that sets up the circuit for the following change. The dynamic imperativeness use is less a direct result of the low question between the PMOS and NMOS transistors.

B. Instance of Operation

The going with case is relied upon to additionally clarify the beforehand specified circuit activity. Just two possible state change subsist for this level shifter, when the yield is high and the accompanying progress is falling, or when the yield is low and the accompanying change is hoisting.

1) For the primary case, when the yield is high, the accompanying advancement is falling change is appeared in Fig. 2. To setup this progress, the entryway of PL is associated with the middle of the road supply voltage V_{ddm} and the door of PR is associated with node D. This association predispositions PL into the close cutoff locale of activity, which corrupts the drive life of PL. Without struggle from PL, as appeared in the figure, node D releases through the draw down system NL. As appeared in Fig. 2, node Db is charged to the full voltage by the draw up arrange PR. After a postponement, the criticism motion from node D proliferates to the select contribution of MUXL and MUXR (the input way appeared in Fig. 1), which is associated with the door of PL and PR. This event sets up the condition of the level shifter for the following change.

2) The second case is presented in Fig. 2. In this progress, the level shifter works likewise, as depicted in the in the primary case; regardless, every undertaking is reflected to the next differential branch.. Node D is released through NR, while the current gave by transistor PR is less because of the middle supply voltage V_{ddm} (associated with the door of PR).

III. SIMULATION RESULTS

The circuits from Fig. 1 are downsized to 12nm with reference to [5] and [6] for scaling from 16nm to 12nm is as per the following: (i)With the assistance of a verilog-A coding, a 12nm FinFET image was produced, (ii)Basic segments required for the proposed level shifter, for example, inverter, voltage divider and two multiplexers(MUXL and MUXR) were created utilizing 12nm FinFET's[7], and (iii)Finally, the level shifter circuit was built utilizing the fundamental segments as appeared in Fig.4. This was propelled with ADE L and recreated for DC examination as appeared in Fig.5. From Fig.5., we can watch that the low information voltage was moved from 250mV to 500mV. Fig.6. demonstrates the power dispersal of Fig.1.a topology when recreated in Cadence Virtuoso at 12nm innovation node which is 284.1229nW. This is around 23nW lesser contrasted and 16nm innovation node topology from[1].

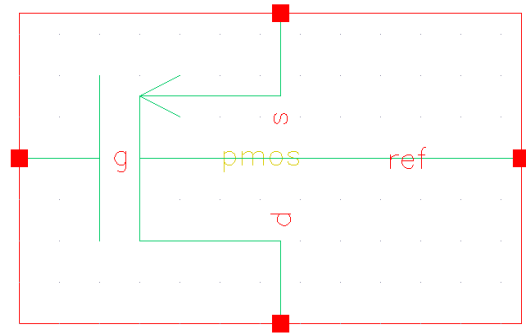

Fig.3. 12nm FinFET symbol generated using verilog-A coding.

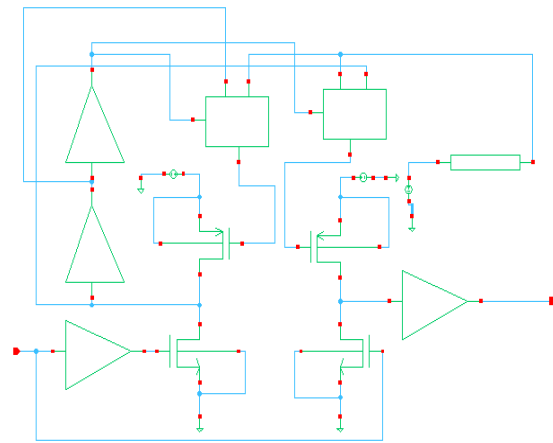

Fig.4. Level shifter circuit in Cadence Virtuoso for Fig.1.a.

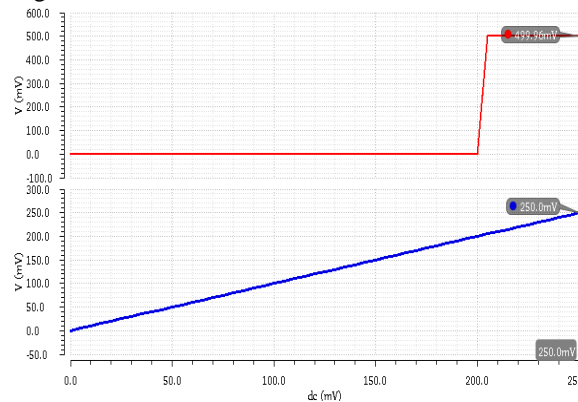

Fig.5. Simulated Output for level shifter of Fig.4. in Cadence Virtuoso Spectre simulator.

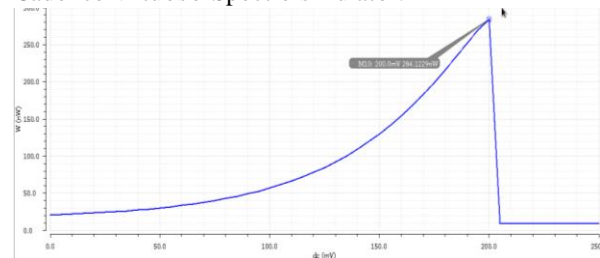

Fig.6. Power dissipation of Fig.1.a topology in Cadence Virtuoso.

Parameters	Dimensions	
Technology Node[L]	12nm	
Vt	200mV	170mV
Temperature	27° C	125° C
W _{fin}	10nm	
H _{fin}	4µm	
In	250mV	
Out	499.56mV	
V _{ddh}	500mV	
Total Power	284.1992nW	

Table I: Table 2: Design Parameters Used for 12nm FinFET Level Shifter of Fig.1. a

Table II Comparison table for 16nm [1] and 12nm level shifter topology

Sl. No	Technology node	Level shifting		Power
		From	To	
1	16nm[1]	250mV	790mV	307nW
2	12nm	250mV	500mV	284.1229nW

IV. CONCLUSION

The proposed level shifter has gave off an impression of being sensible for coordination in sub-30-nm multi-voltage zone microchips when downsized to 12nm. The reproductions demonstrate that the level shifter moves the low info voltage space from 250mV to 500mV with control dispersal of 284.1229nW(around 23nW not as much as the 16nm topology). The proposed converter, subsequently, reinforces close edge circuits despite the extended affectability to process assortments i.e The proposed converter, thusly, underpins close limit circuits notwithstanding the expanded affectability to process varieties.

V. FUTURE SCOPE

The converter must keep up symmetric rise and fall change times over the greatest voltage change at different temperatures. Also, the proposed converter must display critical enhancements in speed, vitality, and power proficiency.

ACKNOWLEDGMENT

I would like to take this opportunity to thank and express my gratitude to Dr. A Sreenivasan, PG Director and also to Dr. T C Manjunath, HOD, Dayananda Sagar College of Engineering, Bangalore. Their incessant encouragement and valuable technical support have been immense help in realizing this paper.

I would take this opportunity to express my sincere gratitude to Dr. Kiran Gupta, PG Co-ordinator, Department of E&C for her guidance which gave us the environment to enhance our knowledge, skills and to reach the pinnacle with sheer determination, dedicated and hard work.

Guidance and deadlines play a very important role in successful completion of the paper on time. I convey my gratitude to my guide, Dr. Jayadeva T S, Asst. Professor, Department of ECE,DSCE.

REFERENCES

- [1] "Power Efficient Level Shifter for 16 nm FinFET Near Threshold Circuits," Alexander Shapiro and Eby G. Friedman, IEEE Transactions On Very Large Scale Integration (Vlsi) Systems, Vol. 24, No. 2, February 2016.
- [2] V. Kursun, R. M. Secareanu, and E. G. Friedman, "CMOS voltage interface circuit for low power systems," in Proc. IEEE Int. Symp. Circuits Syst., vol. 3. May 2002, pp. 667–670.
- [3] S.-C. Luo, C.-J. Huang, and Y.-H. Chu, "A wide-range level shifter using a modified Wilson current mirror hybrid buffer," IEEE Trans. Circuits Syst. I, Reg. Papers, vol. 61, no. 6, pp. 1656–1665, Jun. 2014.
- [4] S. Lütkemeier and U. Ruckert, "A subthreshold to above-threshold level shifter comprising a Wilson current mirror," IEEE Trans. Circuits Syst. II, Exp. Briefs, vol. 57, no. 9, pp. 721–724, Sep. 2010.
- [5] M. Ashouei, H. Luijmes, J. Stuijt, and J. Huisken, "Novel wide voltage range level shifter for near-threshold designs," in Proc. 17th IEEE Int. Conf. Electron., Circuits, Syst., Dec. 2010, pp. 285–288.
- [6] B. H. Calhoun and D. Brooks, "Can sub threshold and near-threshold circuits go mainstream?," IEEE Micro, vol. 30, no. 4, pp. 80–85, Jul./Aug. 2010.

- [7] "Compact modeling of ultra - scaled . Triple gate finfets in verilog -A," Supervisor : charalambos dimitriadis, Ioannis messaris, thessaloniki, october 2013.
- [8] "Level shifter design for low power Applications," Manoj Kumar, Sandeep K. Arya, Sujata Pandey, International journal of computer science & information Technology (IJCSIT) Vol.2, No.5, October 2010.
- [9] "Design procedures for differential cascode voltage switch circuits," Kan m. Chu and david i. Pulfrey, member,IEEE, IEEE-journal of solid-statecircuits,vol. Sc--1,no. 6, december1986.