

A Study on Types of the Electricity Theft by Consumers

Shekhar Y Khot, Dr. Hari Kumar Naidu, Prof. Pratik Gutke

MTech student, Tulsiram Gayakwad Patil College of Engineering Nagpur, Rashtrasant Tukadoji Maharaj Nagpur University, Maharashtra, India

Professor electrical engineering department, Tulsiram Gayakwad Patil College of Engineering Nagpur, Rashtrasant Tukadoji Maharaj Nagpur University, Maharashtra, India

Assistant Professor electrical department, Tulsiram Gayakwad Patil College of Engineering Nagpur, Rashtrasant Tukadoji Maharaj Nagpur University, Maharashtra, India

Abstract- Electricity theft can be in the form of fraud (meter tampering), stealing (illegal connections), billing irregularities, and unpaid bills. The evidence shows that theft is increasing in most regions of the world. The financial impacts of theft are reduced income from the sale of electricity and the necessity to charge more to consumers. Electricity theft is closely related to governance indicators, with higher levels of theft in countries without effective accountability, political instability, low government effectiveness and high levels of corruption. Electricity theft can be reduced by applying technical solutions such as tamper-proof meters, managerial methods such as inspection and monitoring.

1. INTRODUCTION

1. Defining electricity theft

Four kinds of “theft” are prevalent in all power systems. The extent of the theft will depend upon a variety of factors from cultural to how the power utility is managed.

2. Fraud

Fraud is when the consumer deliberately tries to deceive the utility. A common practice is to tamper with the meter so that a lower reading of power use

3. Stealing electricity

Electricity theft can be arranged by rigging a line from the power source to where it is needed bypassing a meter.

4. Billing irregularities

Billing irregularities can occur from several sources. Some power organizations may not be very effective in measuring the amount of electricity used and unintentionally can give a higher or lower figure than the accurate one.

Some persons and organizations do not pay what they owe for electricity. Residential or business consumers may have left the city or an enterprise has gone bankrupt.

5. Method of electricity theft

Theft can be estimated, but not measured exactly. The most accurate estimate of theft is by conducting a thorough analysis of the power system

- Power theft

Defined as a conscience attempt by a person to reduce or eliminate the amount of money he or she will owe the utility for electric energy.

- Illegal Connection

- Meter related problems Meter bypass/ tamper Wrong readings “U- TOUCH” High meter position Faulty meter , meter ratings Over aged meters Incorrect C.T. multiplying factor Meter Transfers

- Billing Problems

- Premises connected but a/cs not set up in System.

- Wrong classification

- Under keying of meter reading

- Customers with zero readings

- Over clocked meter readings

- Un metered/flat rate supplies

- Under estimation

- Unpaid bills

II. TYPE OF ELCTRICITY STEALING IN ENERGY METER

- Short line-line connection.

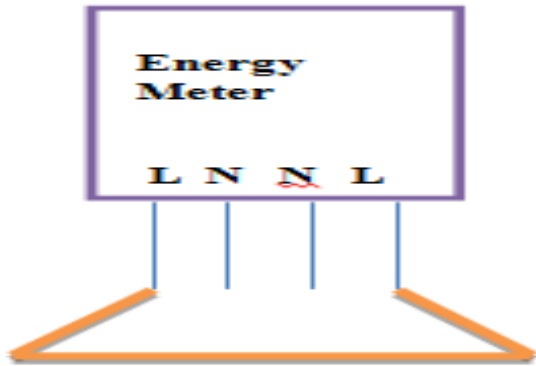
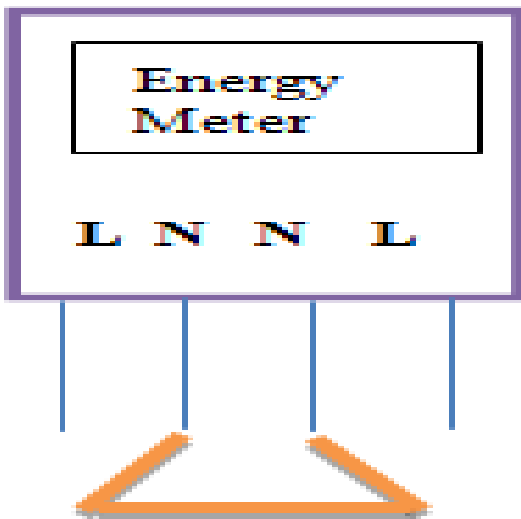

Fig.(i) direct line to line connection
The stealing of electricity by making direct connection between input line wire to output line wire.

- Short neutral-neutral connection.



Fig(ii) neutral to neutral connection
The stealing of electricity by making direct connection between input neutral wire to output neutral wire.

- Direct connect with energy meter.

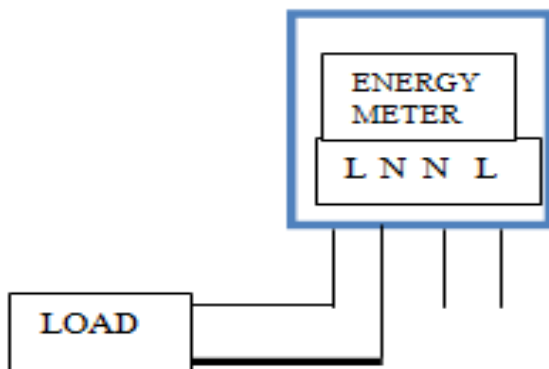

Fig(iii) direct connection with load



Fig.(iv) direct connected with load actual prototype

Meter fraud: In many areas where manual reading of the meter is done, the person is often bribed to give false reading and thus the amount paid is for lesser amount of power compared to the power actually consumed. Also meters are tampered by obstructing motion of the disk and tampered current transformer present in energy meter.

- With inserting pin in energy meter.
Power tapping: often power theft is done during transmission by illegal tapping of the power lines to divert the power to the required destination. It is also done by illegal connection to the power grid station, which is cut at the time of billing.



Fig(v) pin type tampering



III. RESULT AND CONCLUSION

The vivid evidence provides the innumerable levels of power theft in India. It can be prevented by using smart energy meter with microcontroller as an identifier for power theft.

REFERENCES

- [1] T.B. Smith, "Electricity theft- comparative analysis," Energy Policy, vol. 32, pp. 2067–2076, Aug. 2003.
- [2] "Electricity thefts on the rise," <http://www.wtsp.com/news/local/story.aspx?storyid=109056>.
- [3] "Electricity theft: Dangerous trend that's costing honest Houstonians money," <http://www.khou.com/news/Electricity-theft-a-dangerous-trend-thats-costing-honest-Houstonians-money-92450694.html>.
- [4] "Anti theft," Maharashtra State Electricity Distribution Company, [Online]. Available: <http://www.mahadiscom.in/anti-theft-photo/anti-theft-photo-01.jpg>.
- [5] V. J. Vibhute, "The 8051Microcontroller". Chapter 4, 5, Second edition, publication-Tech Max.