

A Simple Design Concept of Hardware for Single Phase Five Level Inverter

Ms. Komal Shende¹, Dr. HariKumar Naidu², Vaishali Pawade³

¹PG. Scholar, Electrical Engineering, Tulsiramji Gaikwad Patil College of Engineering and Technology

²Professor Head, Electrical, Tulsiramji Gaikwad Patil College of Engineering and Technology

³Prof., A.P, Electrical Engineering, Tulsiramji Gaikwad Patil College of Engineering and Technology

Abstract- An inverter is utilized to transform a Direct Current (DC) source into an Alternating current (AC) source using electronic switches. While converting DC to AC, it is conceivable to acquire the preferred output voltage and frequency by two types of inverters, one is two level and another one is Multi-Level Inverter (MLI).

Cascaded H-Bridge type of Multi-Level Inverter is more efficient compare to the other topologies of Multi-level inverter. Minimum Total Harmonic Distortion(THD), reduced EMI are the advantages of Multi-Level Inverter(MLI), and it can be operated on different voltage levels. MOSFETs are used as switches. In this Paper, Hardware result and the design of single phase 5-level cascaded Multi-level inverter with separate DC sources are presented

Index Terms- Micro-controller, multilevel inverter, Simulink, Total harmonic distortion (THD) 5-level.

1. INTRODUCTION

Inverter is a device, which transforms a DC source into an AC source. In the real world, all loads appliances machines do not use direct current (DC) power supply as their sources. Induction heating, HVDC transmission, Uninterruptible power supply, electric motor speed control require alternating current (AC) source. If the only available supply is DC, then the conversion of DC to AC is needed, when the loads or any applications require AC power source. In these situations there is a need of inverters. So the inverters show a very significant character in the real world.

In recent years many industrial applications need higher power devices .The moderate voltage and higher power like megawatt power level are requisite by certain moderate voltage motorized drives and utility uses, hence a multi-level power inverter

association progresses as an unusual in high power and medium voltage circumstances The conventional inverters yield an output voltage with levels $\pm V_{dc}$, which are termed as the two level inverter. But this output is not a sinusoidal wave. To obtain nearly sinusoidal wave, multi-level inverters are used. Conventional inverters cannot be called as multilevel inverters. If the output of inverter consists of more than 2 levels then only that type of inverter can be called as multilevel inverter. Three level inverter is the initiation of multilevel concept. However, the fundamental perception of a multilevel inverter is to attain higher power with the use of sequence of H-Bridges with numerous low voltage Direct current sources to accomplish the power transformation by generating a set of steps or stepped voltage waveform. Input Direct current sources to the multilevel inverter may be either Batteries or Capacitors or any renewable energy voltage sources.

The advantageous features of a Multilevel Inverter are listed below,

1. Staircase output voltage waveform: Output voltages with very low distortion are generated by multilevel inverters and also with reduced dv/dt stresses. Therefore the problems occurred due to electromagnetic compatibility (EMC) will be reduced.
2. Input current: Input current drawn by Multi level inverter is with little distortion.
3. Switching Frequency: Multilevel inverters can be functioned at poorer switching frequency which outcomes in lesser switching loss and greater efficiency

2. DESIGN CRITERIA OF SINGLE PHASE FIVE

LEVEL INVERTER

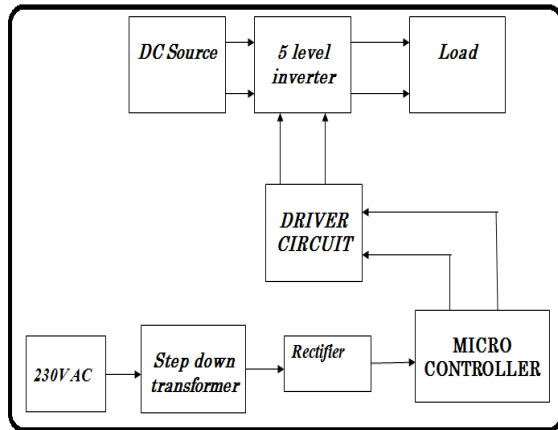

Figure 1. Block Diagram of Multi Level Inverter

1. Design of Diode bridge rectifier and filter circuit:

Input line voltage = 120 Vac
 Output dc voltage = 150 vdc
 Load current = 2 Amp.(max)
 $V_m = \sqrt{2} \times 120 = 169v$
 $V_{dc} = 2 V_m / \pi = 2 \times 396 / \pi = 107(\text{without filter})$

A. Diodes:-

$V_R (\text{max}) > V_m > 169 \text{ Volts}$
 $I_f (\text{ave}) > I_0 > 2 \text{ A}$

Selected diode are D_1 to $D_8 = 1N5408$

Specification:

1.	Maximum Average Forward Rectified Current (I _{av})	3 A
2.	Maximum Recurrent Peak Reverse Voltage (V _{rrm})	400 V
3.	Maximum DC Blocking Voltage (V _{dc})	400

2. Design of main power circuit:

MOSFET bridge While selecting MOSFET

$V_{ds} > 0.707 \times V_{dc} \text{ [let } m_a = 1 (\text{max})]$
 $> 0.707 \times 150 > 106 \text{ volts}$
 $V_{gs} > 12 \text{ volts}$
 $I_d > I_L \text{ max} > 2 \text{ Amps}$

Switching time should be as small as possible

selected MOSFET is IRF460

Specifications

1.	Drain-Source Voltage	500 V
2.	Gate-Source Voltage	+20V/-20V
3.	Continuous Drain Current	20 A
4.	Turn-Off Delay Time	110 ns
5.	Fall Time	58 ns

3. Snubber Circuit:

From data sheet of MOSFET

Turn off delay = 110 ns, Fall time = 58 ns

Let to be design for maximum current capacity of MOSFET i.e. 20 Amps

$$C = I_0 T_{\text{off}} / 2 V_d = 20 \times 168 \text{ ns} / 2 \times 310(156 \text{ for one source hence } 156 \times 2 = 310V) = 0.0068 \mu\text{F}$$

for better performance large capacitor C to be selected. So that MOSFET voltage rises slowly and takes longer time to reach peak value of voltage capacitor are selected as 0.01μF, 1KV volt each. The maximum load current is taken to be 20 A and maximum voltage reading of MOSFET is 500 volt,

$$I_f (\text{ave}) = 20 \text{ A}$$

$$V_K = 500 \text{ V}$$

4. Design of Optocoupler

Selected opto Coupler is 4N35 which has got IRED and phototransistor internally. The maximum forward current for LED = 20 mA

Peak output voltage of ATMEGA16 will be = 5 v

Let maximum current for LED to be selected as 20 mA

$$R = V_i / I_f = 5 / 20 \text{ mA} = 250 \Omega$$

selected R = 270 Ω ¼ w with this value

$$I_f (\text{max}) = 5 / 270 \Omega = 18.5 \text{ mA}$$

which is acceptable value for 4N35

selected Resistors are = 270 Ω ¼ w each.

4N35 requires supply voltage = 12 Vdc

So we design power supply for the rating 100 mA.

Using transformer of 12-0 secondary voltage.

$$V_m (\text{sec}) = \sqrt{2} \times 12 = 17 \text{ V}$$

Selected ripple voltage $V_{\text{rpp}} = 0.5 \text{ V}$

For same voltage, at any input range of AC supply we used a regulator IC as 7812

Hence Vdc = 12 V

Spécification of 4N35

1.	Collector emitter breakdown voltage	70 V
2.	Collector current	100 mA
3.	Forward current	20 mA
4.	Reverse voltage	6 V

5. Diodes:

$$PIV > V_m$$

$$> 17 \text{ V}$$

$$I_f > I_1$$

$$> 500 \text{ mA}$$

Selected diodes are IN4007

1.	Maximum Average Forward Rectified Current (Iav)	1 A
2.	Maximum Recurrent Peak Reverse Voltage (Vrrm)	1000V
3.	Maximum DC Blocking Voltage (Vdc)	1000 V

6. INVERTER

Input voltage=24V for each h bridge

Output voltage= 48 V (for 5 level)

Motor: Type: Split phase induction motor

- 1) Rated Voltage 110V
- 2) Rated Power (P) 0.25HP
- 3) Main winding stator resistance 2.02Ω
- 4) Main winding rotor resistance 4.12Ω

7. Transformer

Transformer used here is a signal core six isolated secondary with rating 12-0-12, 500 mA each.

3. SUITABILITY OF COMPONENT USED ACORDING TO DESIGN

A.MICROCONTROLLER

A microcontroller is a small computer on a single integrated circuit.Its contain one or more cpus along with memory and programbale input/output peripherals .It is believed the AVR basic architecture was conceived by two students at the Norwegian Institute of Technology (NTH) Alf-EgilBogenand VegardWollan. The original AVR MCU was developed at a local ASIC house in Trondheim Norway, where the two founders of Atmel Norway were working as students. It was known as a μRISC (Micro RISC). Among the first of the AVR line was the AT90S8515, which in a 40-pin DIP package has the same pinout as an 8051 microcontroller, including the external multiplexed address and data bus. The polarity of the /RESET line was opposite

(8051's having an active-high RESET, while the AVR has an active-low /RESET), but other than that, the pinout was identical.

The AVR core combines a rich instruction set with 32 general purpose working registers. All the 32 registers are directly connected to the Arithmetic Logic Unit (ALU), allowing two independent registers to be accessed in one single instruction executed in one clock cycle. The resulting architecture

B.RECTIFIER

A full-wave rectifier converts the whole of the input waveform to one of constant polarity (positive or negative) at its output. Full-wave rectification both polarities of the input waveform to pulsating DC (direct current), and yields a higher average output voltage. Two diodes and a centre tapped transformer, or four diodes in a bridge configuration and any AC source (including a transformer without centre tap), are needed. Single semiconductor diodes, double diodes with common cathode or common anode, and four-diode bridges, are manufactured as single components

C.POWER MOSFETS

Power MOSFETs are well known for superior switching speed, and they require very little gate drive power because of the insulated gate. In these respects, power MOSFETs approaches the characteristics of an "ideal switch". The main drawback is on-resistance RDS and its strong positive temperature coefficient. This application note explains these and other main features of high voltage N-channel power MOSFETs, and provides useful information for device selection and application.

D.ISOLATOR (OPTOCOUPLER)

Optocoupler is a Gallium-Arsenide-Diode Infrared Source Optically Coupled to a Silicon npn Phototransistor. This package permits one way transfer of electrical signal from infra-red emitting diode to photo detector. The effectiveness of this device is stated in terms of the current transfer ratio (CTR). High Direct-Current Transfer Ratio. High-Speed Switching. Typical Applications Include Remote Terminal Isolation, SCR and Triac Triggers, Mechanical Relays and Pulse Transformers

E.VOLTAGE REGULATOR

It is very small in size and low cost fixed voltage IC regulator which require no heat sink and a few or no external component. It require only a filtered D.C voltage .CI is required if regulator is located an appreciable distance from power Supply filter.

F.RELAY

=A relay switch can be divided into two parts: input and output. The input section has a coil which generates magnetic field when a small voltage from an electronic circuit is applied to it. This voltage is called the operating voltage. Commonly used relays are available in different configuration of operating voltages like 6V, 9V, 12V, 24V etc. The output section consists of contactors which connect or disconnect mechanically. In a basic relay there are three contactors: normally open (NO), normally closed (NC) and common (COM). At no input state, the COM is connected to NC. When the operating voltage is applied the relay coil gets energized and the COM changes contact to NO. Different relay configurations are available like SPST, SPDT, DPDT etc, which have different number of changeover contacts.

4. SPEFICATION

Sr. No.	Component	Rating
1	ATMEGA16 Microcontroller	4.5 to 5.5V, 40 Pin
2	IRF460 MOSFET	600V 15A
3	7805 Regulator	5V, 1A
4	7812 Regulator	12V, 1A
5	4N35 optocoupler	NPN
6	12-0-12 Transformer	12V, 500mA
7	Relay	5V, 12C SPDT

5. HARMONIC ELIMINATION

A. Fundamental switching frequency:

The selective harmonic elimination method is also called fundamental switching frequency method based on the harmonic elimination theory. A typical 11-level multilevel converter output with fundamental frequency switching scheme & the Fourier series expansion of the output voltage waveform as shown in equation below.

The conducting angles, $\theta_1, \theta_2, \theta_s$, can be chosen such that the voltage total harmonic distortion is a

minimum. Normally, these angles are chosen so as to cancel the predominant lower frequency harmonics.

For the 11-level case the 5th, 7th, 11th, and 13th harmonics can be eliminated with the appropriate choice of the conducting angles. One degree of freedom is used so that the magnitude of the fundamental waveform corresponds to the reference waveform's amplitude or modulation index, m_a , which is defined as V_L / V_{Lmax} . V_L is the amplitude command of the inverter for a sine wave output phase voltage, and V_{Lmax} is the maximum attainable amplitude of the converter, i.e., $V_{Lmax} = s \cdot V_{dc}$. The equations will now be as follows:

$$\begin{aligned} \cos(5\theta_1) + \cos(5\theta_2) + \cos(5\theta_3) + \cos(5\theta_4) + \cos(5\theta_5) &= 0 \\ \cos(7\theta_1) + \cos(7\theta_2) + \cos(7\theta_3) + \cos(7\theta_4) + \cos(7\theta_5) &= 0 \\ \cos(11\theta_1) + \cos(11\theta_2) + \cos(11\theta_3) + \cos(11\theta_4) + \cos(11\theta_5) &= 0 \\ \cos(13\theta_1) + \cos(13\theta_2) + \cos(13\theta_3) + \cos(13\theta_4) + \cos(13\theta_5) &= 0 \\ \cos(\theta_1) + \cos(\theta_2) + \cos(\theta_3) + \cos(\theta_4) + \cos(\theta_5) &= 5m_a \end{aligned}$$

These equations are nonlinear transcendental equations that can be solved by an iterative method such as the Newton-Raphson method. For example, using a modulation index of 0.8 obtain $\theta_1=6.57^\circ, \theta_2=18.94^\circ, \theta_3=27.18^\circ, \theta_4=45.14^\circ, \theta_5=62.24^\circ$. Thus, if the inverter output is symmetrically switched during the positive half cycle of the fundamental voltage to $+V_{dc}$ at $6.57^\circ, +2V_{dc}$ at $18.94^\circ, +3V_{dc}$ at $27.18^\circ, +4V_{dc}$ at 45.14° , and $+5V_{dc}$ at 62.24° , and similarly in the negative half cycle to $-V_{dc}$ at $186.57^\circ, -2V_{dc}$ at $198.94^\circ, -3V_{dc}$ at $207.18^\circ, -4V_{dc}$ at $225.14^\circ, -5V_{dc}$ at 242.24° , the output voltage of the 11-level inverter will not contain the 5th, 7th, 11th, and 13th harmonic components. Other methods to solve these equations include using genetic algorithms and resultant theory. Practically, the recalculated switching angles are stored as the data in memory (look-up table). Therefore, a microcontroller could be used to generate the PWM gate drive signals.

B. Selective harmonic elimination PWM:

In order to achieve a wide range of modulation indexes with minimized THD for the synthesized waveforms, a generalized selective harmonic modulation method was proposed, which is called virtual stage PWM. An output waveform is shown in Figure. The Virtual Stage PWM is a combination of Unipolar Programmed PWM and the fundamental frequency switching scheme. The output waveform

of Unipolar Programmed PWM is shown in Figure. When Unipolar Programmed PWM is employed on a multilevel converter, typically one DC voltage is involved, where the switches connected to the DC voltage are switched “on” and “off” several times per fundamental cycle

6. HARDWARE SET-UP MODEL

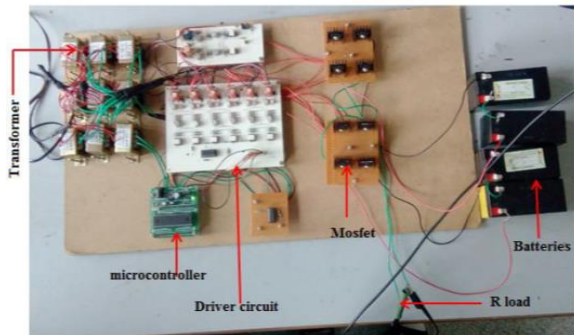

Figure 2. Hardware Model of five level inverter

7. HARDWARE OUTPUT RESULT

With inverter specifications, simulation has been carried out and the output voltage obtained from the Simulink model.

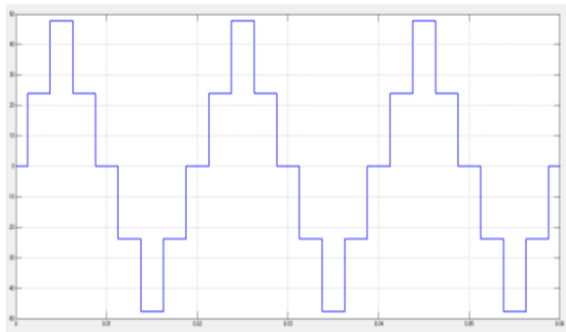

Figure 3.output voltage of five level inverter

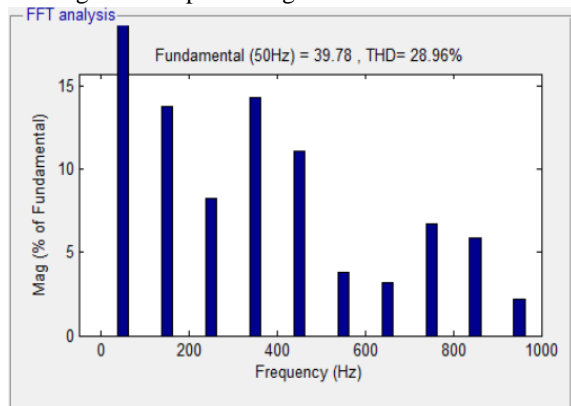

Figure 4.THD calculation from FFT analysis

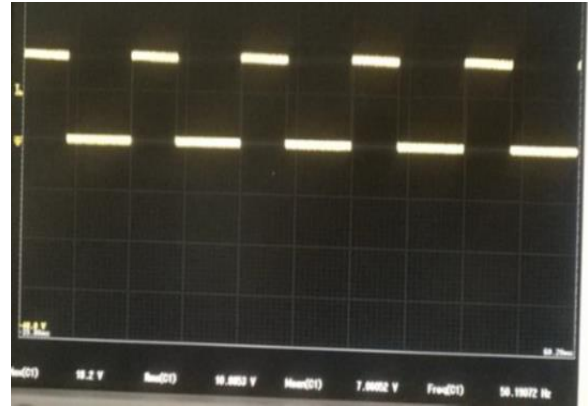

Figure.5.Driver circuit Output

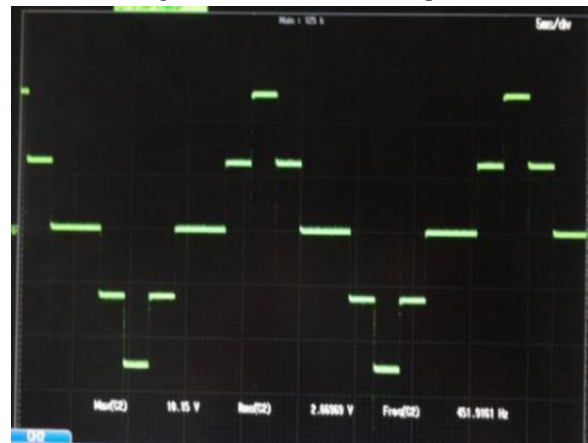

Figure 6.Output voltage across R load

8. ADVANTAGES AND DISADVANTAGE

The advantageous features of a multilevel inverter are listed below,

- A. Staircase output voltage waveform: Output voltages with very low distortion are generated by multilevel
- B. inverters and also with reduced dv/dt stresses. Therefore the problems occurred due to electromagnetic compatibility (EMC) will be reduced.
- C. Input current: Input current drawn by Multi level inverter is with little distortion.
- D. Switching Frequency: Multilevel inverters can be functioned at poorer switching frequency which outcomes in lesser switching loss and greater efficiency

The disadvantage of a multilevel inverter.

- A. High component count
- B. Some configuration need more than one isolated dc supply.

9. CONCLUSION

In this paper, simulation of 5 level inverter has been proposed and the hardware prototype of 5 level inverter using microcontroller AT89C51 is implemented. Future work will be towards the implementation of 7, 9 and 11 level inverters. As the levels of output increases, nearly sinusoidal waveform will be obtained, this result in reduced THD. So the benefits of multilevel inverter include, lower transient power loss due to low-frequency switching, less THD, reduced ac filters, and possibility to replace MOSFETs with IGBTs, and thereby providing compact power conversion. It can be concluded that, in order to maintain the good quality of power, it is necessary to replace the conventional drives with 2 level inverters by multilevel inverters.

REFERENCES

- [1] M.H.RASHID “Power Electronics: Circuits, Devices and Applications. Third Edition
- [2] Bimal K. Bose “Power Electronics and Motor Drives Advances and Trends”.
- [3] B. Wu, High-Power Converters and AC Drives. Hoboken, NJ, USA: Wiley, 2006.
- [4] Yashobanta panda, “Analysis of cascaded multilevel inverter induction motor drives “Department of Electrical Engineering, National Institute of Technology, Rourkela, and Odisha, India
- [5] G. Pandian and S. Rama Reddy, “Simulation and analysis of multilevel inverter fed inductionmotor drive” Indian Journal of Science
- [6] J. R. Rodríguez, J.-S.-S. Lai, and F. Z. Peng, “Multilevel inverters: A survey of topologies, controls, and applications,” IEEE Trans. Ind. Electron., vol. 49, no. 4, pp. 724–738, Aug. 2002.
- [7] E. Sakasegawa and K. Shinohara, “Compensation for neutral point potential in three-level inverter by using motor currents,” Trans. Inst. Elect. Eng. Jpn., vol. 121-D, no. 8, pp. 855–861, 2001.
- [8] G.Swapna, V.HimaBindu, M. P.M.Sarma “Hardware Implementation of a Single Phase Inverter”, International Journal of Engineering Trends and Technology (IJETT) – Volume 4 Issue 8- August 2013 Hyderabad, India