

Pediatric Size Swallowable Glass Pill for Digestive Motility Analysis

P.Arun Kumar¹, J.Divineson Raj², R.Karthick³, G.Indhumathi⁴

^{1,2,3} UG Student/ Department of ECE, Loyala institute of technology, Chennai 600123

⁴Assistant Professor/Department of ECE, Loyala institute of technology, Chennai 600123

Abstract- A glass pill for digestive motility tracking with wireless communication is presented. The pill encapsulates three magnetic transmitter coils with a 125 kHz signal, the circuitry required to control the magnetic coil output and the battery. The system provides real time location of the pill inside the digestive tract of the patient using an external detector housed in a wearable jacket. The custom integrated circuit for this application reduces bill-of-materials (BOM) count and significant reduction in power consumption therefore resulting in further size reduction by adapting a smaller battery package. The outcome of the circuit integration enables the glass pill for pediatric use while providing a total pill diameter of 6 mm. The glass pill system operates continuously for 48 hours with a 1.55 V 8 mAh coin cell battery with an average power consumption of 250 microwatts.

Index Terms- Magnetic sensor, position measurement, CMOS analog integrated circuit, glass encapsulation.

I. INTRODUCTION

Electronic miniaturization and microsystem development has opened several medical diagnosis applications during the last decades. Focusing on the digestive system, the use of pills equipped with cameras instead of classic endoscopy system enables inspection of the digestive system without discomfort or need for sedation, thus preventing risks of conventional endoscopy [1], [2]. Multisensor pills that can monitor pH and temperature throughout the gastrointestinal tract are also used as indicators for gastric diseases [3]. However, there are other digestive functional diseases that cannot be diagnosed with a visual recognition of the whole digestive tract such as constipation, diarrhea, irritable bowel syndrome (IBS) or gastro paresis. For those diseases the crucial information is to gather information on the mobility of the pill through the

digestive tract. The previous work, which is focused on the study of the digestive motility and the intraluminal movements, use a magnetic pill and a magnet tracking system (MTS) with 16 magnetic sensors [4]. This work enables the detection of the location of the glass pill by using an active magnetic field instead of a fixed magnet. The first goal of using active magnetic field instead of passive permanent magnet is to be insensitive to earth magnetic field. The earth magnetic field is not homogeneous, especially inside buildings, and it cannot be separated from magnetic field from a permanent magnet. Consequently, active magnetic field generation, with modulated magnetic field, allows ambulatory measurement with variable earth magnetic field vector. The second advantage is to use several capsules simultaneously, because permanent magnets attract each other, which is not the case for generated active magnetic fields. For this purpose, an active RF transmitter and multi-axis coils are used in order to generate the active magnetic field.

The power consumption of this new system is noticeably reduced using the supply voltage control and timing optimization techniques. The output voltage of the DC-DC converter of the system is based on the requirements during different phases: idle, reception and magnetic emission. For instance, the voltage is largest during magnetic emissions and the smallest in idle state. The timing optimization concerns especially the microcontroller sleep time and the minimization of the inductive listening window. The microcontroller clock frequency is also optimized, based on the calculation and timing requirements of the system.

II. POSITION SENSING TECHNIQUE

The presented solution consists of an autonomous glass pill system with three integrated coils (one for each axis) that generates 125 kHz RF signal as depicted in Fig. 1. The principle of the tracking system is very similar to the one presented in [5], which is used to detect the position of a fixed magnet with a wearable receiver consisting of Hall Effect sensors.

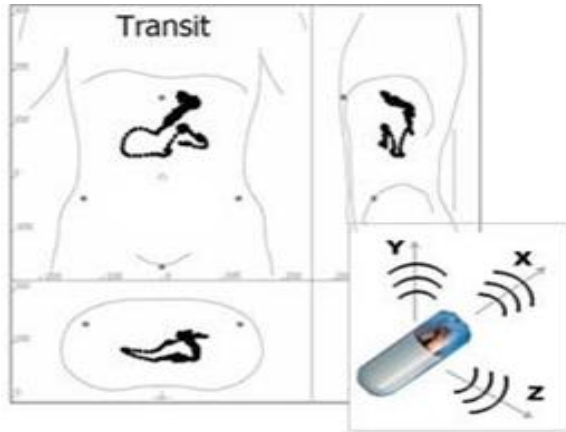

Fig. 1. The magnetic tracking system determines the position of the pill inside the digestive tract.

The position of the pill inside the digestive tract is determined by analyzing the magnetic field generated by the pill in three-axis. Each coil transmits pulses during 2 ms and always in the same sequence, X>Y>Z, and repeated at every 100 ms. The timing constraint allows five pills to be scanned simultaneously without timing collision as depicted in Fig.2. The communication of five pills is based on Time-Division Multiple Access (TDMA). Each capsule receives an ID at wake-up. This ID is used for synchronization using the 125 kHz emission. A capsule is only allowed to emit after its synchronization.

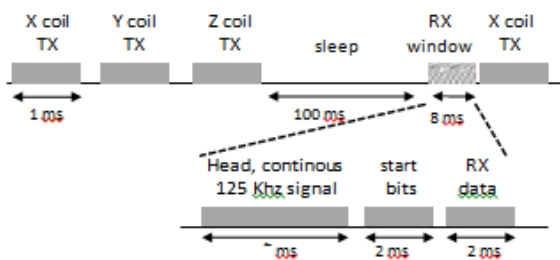

Fig. 2. Data packets included in the transmission and reception frames.

III. SYSTEM BLOCK DIAGRAM AND CUSTOM INTEGRATED CIRCUIT

The block diagram of the glass pill is shown in Fig. 3. It consists of three coils, which are composed of a ferrite on x- axis and air coils on y and z-axis. The coils generate magnetic field during transmission and detect the 125 kHz magnetic field signal during reception in three axes. The magnetic field during transmission is generated by the current provided by the class- D power amplifier. The capacitance of that LC tank is formed by a fixed passive component and a selectable value from a capacitor bank in order to ensure resonant operation between the coil inductance and the integrated circuit for efficient signal transmission.

The rectifier is used to detect the RF signal for first use in order to wake up the integrated system and a ring oscillator provides the clock for the power amplifier transmission as well as the finite state machine (FSM) clock. The FSM includes serial peripheral interface (SPI) for communication with the external microcontroller in addition to the transmission sequence function for position sensing. The transmitter architecture, which is chosen for magnetic field transmission is based on a tuned LC tank composed of a coil and a tunable capacitor connected in parallel with that coil as shown in Fig. 4. This LC tank is driven by a class- D power amplifier in a full-bridge configuration. Two options are available to control the full-bridge driver: a) pulse with selectable length or b) two short pulses with selectable distance between them. Each method can be preferable based on the trade-off between the quality factor tuning or overall power efficiency [6]. The receiver block diagram is presented in Fig. 5. The downlink communication is required in order to receive the

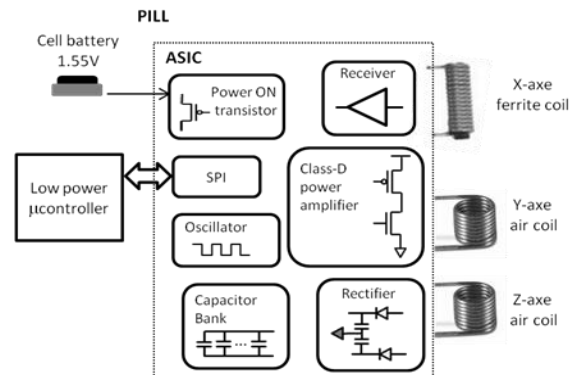

Fig. 3. Block diagram of the components included inside the pill, with the circuitry included inside the ASIC.

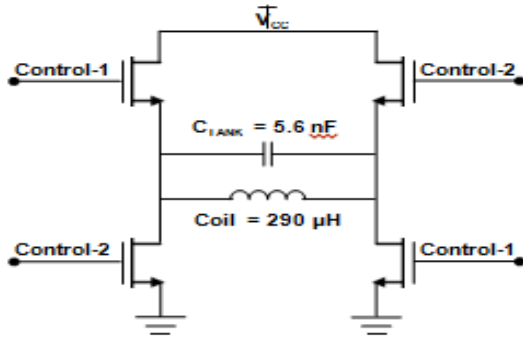

Fig. 4. Schematic of the full-bridge power amplifier initiation command from the base station before any transmission occurs since the system stays on idle mode. The downlink communication is also used to receive resonant capacitor tuning settings. The receiver provides the clock synchronization information from the base station and the circuit adjusts the clock frequency and synchronization through the frequency comparator and the tunable oscillator.

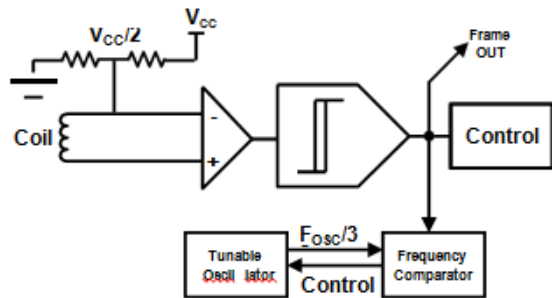

Fig. 5. Receiver block diagram

If no data is received during the RX window time, it could be due to the fact that the base station is not transmitting or due to a bad orientation of the receiving coil with respect to the transmitted magnetic field. To ensure the proper reception from the base station, the receiving coil is changed consecutively (X>Y>Z) each time if there is no reception. To do so, the receiver is connected to each one of the three coils subsequently during listen mode through a multiplexer. A tunable 3-bit Schmitt trigger comparator is utilized to ensure the detection of the input signal with respect to different amplitudes based on the input magnetic field strength by adaptively changing the gain of the comparator. An RF wake-up circuit based on a passive rectifier is shown in Fig. 6. The circuit detects magnetic field in order to wake up the system from storage state to active operation. The storage state provides a two year of shelf life before reaching to the patient.

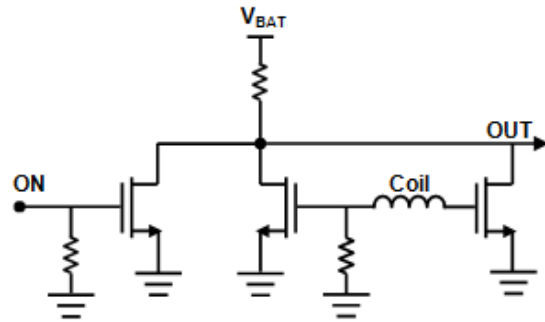

Fig. 6. Schematic of the start-up rectifier

In order to obtain desired form factor of the capsule, where the diameter is much smaller than the length, a ferrite core is used to increase the effective diameter of the coil in the x-axis of the capsule. The two orthogonal coils with larger area are air coils. Therefore the three coils have consequently the same effective area. The coils have nominal values of 290 μH, with a quality factor Q=5 for the air coils and a quality factor Q=20 for the ferrite coil. The required capacitor for resonance condition is 6.5 nF for 125 kHz operation. A 1.8nF 5-bit binary-weighted integrated capacitor together with a 4.7 nF discrete capacitor accounts for the process variations and ensures resonant operation of the transceiver. The oscillator of the circuit, which is based on a five-stage current-starved ring oscillator with bias current tuning capability for frequency tuning, is depicted in Fig. 7. The target center frequency of the oscillator is 4 MHz. Since a frequency deviation of 0.5 kHz (0.4%) for transmission is allowed on the tracking system, the frequency of the oscillator is tuned by a 10-bit adaptively controlled binary-weighted current source based on the reference frequency information received from the base station. A divide-by-32 clock divider compares the internal oscillator frequency (4 MHz ÷ 32 = 125 kHz) to the 125 kHz reference clock and tunes the oscillator frequency through the digital control process of the finite state machine.

IV. EXPERIMENTAL RESULTS

The layout of the custom integrated circuit, which is fabricated on UMC 0.18μm CMOS process has a die size of 1.5 mm x 3 mm, is shown in Fig. 8. Approximately half of the silicon area is composed of the tunable capacitor bank for ensuring the resonant operation against variations on CMOS fabrication process and coil manufacturing tolerances.

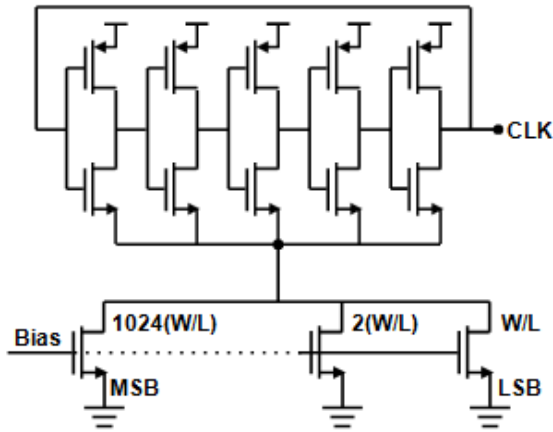

Fig. 7. Schematic of the five-stage tunable oscillator.

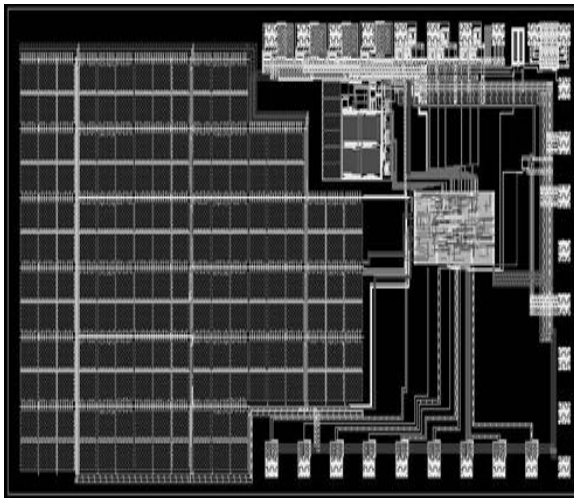

Fig. 8. Layout of the pill's custom integrated circuit. The complete encapsulated glass pill system including the custom integrated circuit is presented in Fig. 9. The proposed pill which has the monolithic transceiver (left) has a diameter of 6 mm compared to the 8 mm diameter of the previously implemented discrete component system (right).

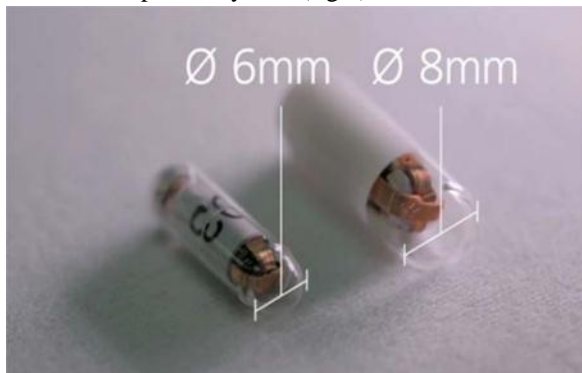

Fig. 9. The developed pediatric capsule (left) next to the adult capsule (right).

After the system is assembled, the coils has to be calibrated for desired operation frequency of 125 kHz. The calibration is performed in two steps. First step is to determine the capacitor value that is necessary to have the LC tank of each coil resonating at 125 kHz. Second step is to determine the ON time of the power amplifier that is necessary to transmit the required magnetic transmission. That calibration process may be done with an external magnetic field detector or with an integrated internal calibration process, based on a predictive algorithm [8]. The calibration process ends by writing the register values for the integrated capacitor bank and putting the system in standby mode. Once the pill is ready to be used by the patient, it is activated by the strong magnetic field that is detected by the rectifier operating as an RF wakeup circuit.

The rectifier and corresponding wake up circuit toggles the input of the pass transistor when its input voltage goes above 600 mV. The measured distance of 2 cm from the wearable base station, which is in the vicinity of the device, ensures the strong field requirement for wake-up and preventing accidental wake-ups. On rare occasions strong AC magnetic field can wake-up the capsule. No medical device like MRI, ECG monitor and other medical device can trigger the capsule at a reasonable distance. However, magnetic fields that are sufficient for triggering the capsule can be achieved at very close proximity while respecting electromagnetic compatibility rules. After such accidental trigger, the capsule verifies the signature of the magnetic emitter. If it is not a match to the expected base station signature, the capsule is subsequently switched off and return to the storage state.

The pass transistor which acts as the main switch between the battery and the circuit is measured as $1.75 \times$ for the ON state and $500 M \times$ for the OFF state. Both the voltage drop during on state (3.5 mV at 2 mA) and the leakage current during the on state are minimized (3.1 nA). The small leakage current ensures the targeted shelf life is sustained during the storage state.

In Fig.10, the operating frequency of the ring oscillator versus on the binary value of the trim code applied to the current source is depicted. Simulation value is compared with three measured samples shows that a maximum of 15 % deviation occurs from the target center frequency of 4 MHz and it is

achievable within the trim codes of the 10 bit tuning range and while providing an accuracy of 0.4 kHz for the 125 kHz clock.

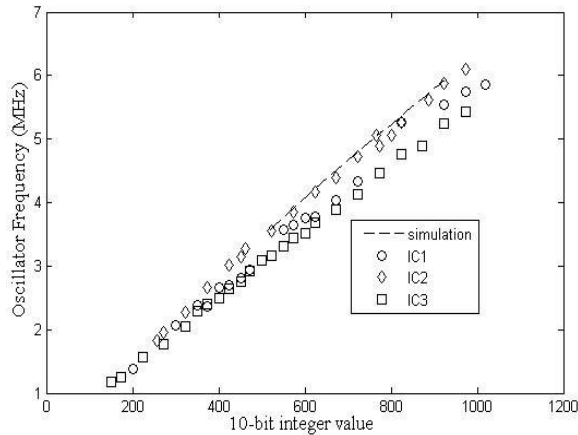

Fig. 10. Measurement results of the oscillator with three different ASICs

The maximum operation distance of the transmitter and the pill is measured while the transmitter coil and the pill coils are aligned on the horizontal axis. The maximum distance is measured between 43 to 80 cm. It is also shown in Fig.11 that the gain of the hysteresis comparator inside the receiver can be selected with the trigger code input [7]. The maximum read range variation is observed from chip to chip while using identical gain configuration, which is a result of fabrication tolerances of the coils and random mismatch of the integrated receiver elements. Those can be improved with better control of coil fabrication tolerances and mismatch insensitive circuits.

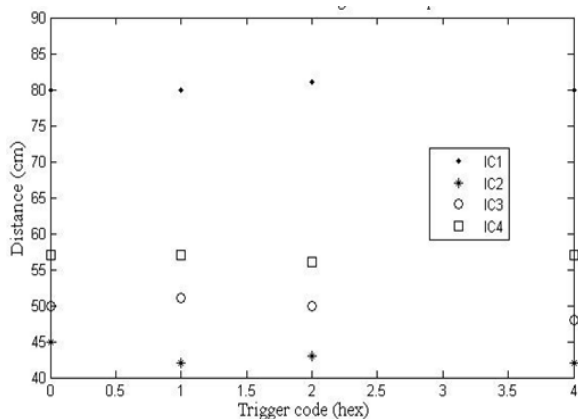

Fig. 11. Maximum operation distance between the pills and the base station

The average power consumption of the tracking pill with this new integrated circuit measured as 250 μ W. Compared to the previous generation tracking pill

with discrete components, which has an average power consumption of 1.15 mW, this new circuit bring 4.6 times reduction in the power consumption while retaining identical functionality. In order to provide the same autonomy of 48 hours, the current system requires a smaller 8 mAh coin battery and enables the integration in a smaller capsule with a diameter of 6 mm. This eventually allows the system to be utilized for pediatric patients, which has been the primary goal of this work.

V. CONCLUSION

A glass pill to determine its position inside the digestive tract has been implemented by an integrated CMOS solution for low-power consumption and integration in a smaller en- capsulation. The building blocks of the system have been presented where trimming of design parameters are highlighted for satisfying the system requirements on accuracy. The system exhibits a maximum operation distance up to 80 cm in the set of measured integrated circuit samples. The integrated solution brings 4.6 times reduction in average power consumption, reducing it from 1.15 mW to 250 μ W allowing the new implementation to require a smaller battery package for the same autonomy. The size reduction of the system due to circuit integration together with a small battery results reduces the encapsulation size and therefore enables the use of the tracking pill for pediatric patients.

REFERENCES

- [1] G. Ciuti, A. Menciassi, P. Dario, "Capsule Endoscopy: From Current Achievements to Open Challenges", *IEEE Reviews in Biomedical Engineering*, vol. 4, pp.59-72, 2011
- [2] G. Pan, L. Wang, "Swallowable Wireless Capsule Endoscopy: Progress and Technical Challenges", *Gastroenterology Research and Practice*, 2012
- [3] E.A. Johannessen, Lei Wang, C. Wyse, D.R.S. Cumming, J.M. Cooper, "Biocompatibility of a Lab-on-a-Pill Sensor in Artificial Gastrointestinal Environments", *IEEE Transactions on Biomedical Engineering*, vol. 53, pp.2333-2340, 2006

- [4] E. Stathopoulos, V. Schlageter V, B. Meyrat, Y. Ribaupierre, P. Kucera, "Magnetic Pill Tracking: A Novel Non Invasive Tool for Investigation of Human Digestive Motility", *Neuro gastroenterology & Motility* vol. 17, pp.148-154, 2005
- [5] P. Hiroz, V. Schlageter, J.C. Givel, P. Kucera, "Colonic Movements in Healthy Subjects as Monitored by a Magnet Tracking System", *Neuro gastroenterology & Motility*, vol. 21, pp.838-857, 2009
- [6] J.L. Merino, C. Dehollain, "LC Tank Full Bridge Control for Large Coil Variations", 19th IEEE International Conference on Electronics, Circuits and Systems (ICECS), pp.653-656, 2012
- [7] J.L. Merino, O.Kazanc, N. Brunner, V. Schlageter, M. Demierre, C. De- hollain, "Low Power Receiver for Magnetic Digestive Motility Tracking Pill", IEEE International Symposium on Circuits and Systems (ISCAS), pp. 469-472, May 2015
- [8] J.L. Merino, C. Dehollain, "Predictive Calibration Technique for Mag- netic Field Position Sensors", 5th IEEE International Workshop on Advances in Sensors and Interfaces (IWASI), pp.136-141, 2013