

Smart Secure Safe Box Using IOT

Prakhar Joshi¹, Ayushi Patel², Prajwal Jaiswal³, Shashwat Bajpai⁴, Suraj Rasal⁵

^{1,2,3,4} Student, Bharati Vidyapeeth (Deemed to be) University, College of Engineering, Pune, India

⁵ Assistant Professor, Bharati Vidyapeeth (Deemed to be) University, College of Engineering, Pune, India

Abstract- Smart Secure Safe Box using Internet of Things is used for watching known threats in real time. Camera Recording System is used to observe unusual activity going on to prevent crime. Today most of the people have CCTV cameras to record all the uncertain activities but they only check when any theft or crime takes place. So we have to design an efficient and faster system to overcome this problem. This paper is regarding how we can detect a crime taking place in an enclosed environment and catch the theft in an efficient manner. As this technique provides absolute security by detecting unusual activity it gives an immediate alert to the authorized user.

Index Terms- CCTV, IOT, Raspberry Pi, RPi Camera

I. INTRODUCTION

The term IOT can be defined as the combination of various computing devices, mechanical and digital machine as well as relationship between objects, animals or people that have unique identifiers(UIDs) including the ability to transfer data over network without the need of any direct interaction among human to machine or human to human.

Need of IOT nowadays -

- Because of IOT physical devices stay in touch with one another leading to greater efficiency and higher quality. It also
- allows full transparency. Due to the overall wireless substructure of these smart devices, it requires little to no human involvement, being able to pretty much operate on their own. This allows for greater control and automation leading to more operating productive [1].

IOT is a technological field that converts any electronic device into a smarter one. This not only connects the device to the internet but also provides the user, various important features like real-time analytics, cloud data storage, trigger an action from a remote location, remote notification etc [2].

Raspberry Pi

The components of Raspberry Pi are an700 MHz ARM1176JZF-S processor, RAM, and VideoCore IV GPU also, it is established on the Broadcom BCM2835 system on a chip (SoC). It uses GPU which include Level 2 cache of 128 KB but not the CPU. Its edge is clear because the SoC is stacked beneath the RAM chip [1].

BeagleBone

BeagleBone can be defined as an open source single board computer which consumes low power. It was developed and produced by Texas instruments in collaboration with Newark element 14 and Digi-Key. Cadence or CAD were used for schemas and Cadence Allegro for PCB manufacturing at the time of designing the board (Simulation software was not used).

Arduino

For developing digital devices that have the capability to sense and control both physically and digitally Arduino is an organization that is open source hardware and software company, user community that designs and manufacture single board micro controllers and micro controller kits.

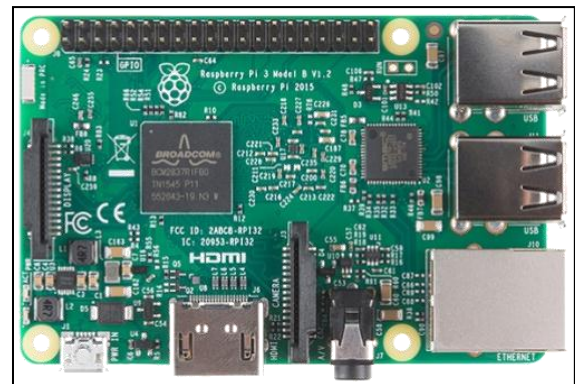

Figure 1. Raspberry Pi 3 B+ Model

Why Raspberry Pi?

As there is a requirement of internet connectivity, camera connectivity and light intensity sensor and Raspberry Pi supports all these three with advanced features and can be programmed using python so we have opted for Raspberry Pi [3].

II. NEED OF SMART LOCKER

This solution is for highly secured reliable smart locker system. The system will effectively detect and control unauthorized access by considering safety of the locker rooms. It will convince users to use system and hence defend their valuable things from robber and also any harm [3], [4]. This system is used where high level security is needed. The future improvement to this work could be done by adding some more aspect such as face recognition. Therefore, the reliability of locker and unauthorized access will be minimized. This could be further applied to identify the illegal entrance [5].

III. PROPOSED RESEARCH METHODOLOGY

In our proposed research work we have tried to overcome limitations of the existing system and design an upgraded smart safe secure box model by introducing the camera and the light intensity sensor in the safe box.

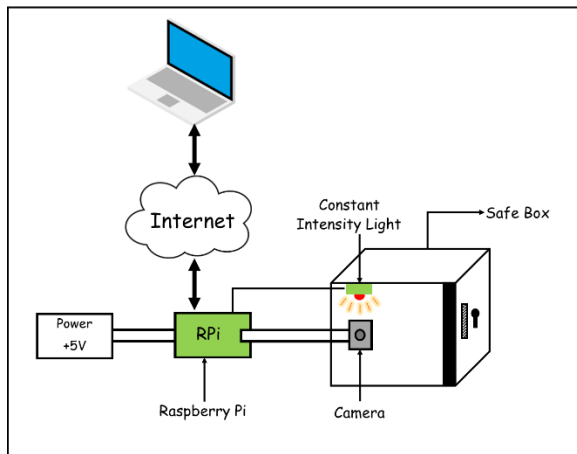

Figure 2. IOT: Smart Safe Box

Working –

When we will keep any item/object in the safe box the camera inside the safe box will capture the image and the image will be saved in the database as a reference image. Now, whenever there will be any change in the safe box i.e. change in the light intensity then the light intensity sensor placed inside

the safe box will force the camera to capture the new image with the help of Raspberry Pi (configured using Python). After this the new image will be compared to the reference image and if there is any change in the image the user will be informed through an alert on the web portal and SMS via Internet.

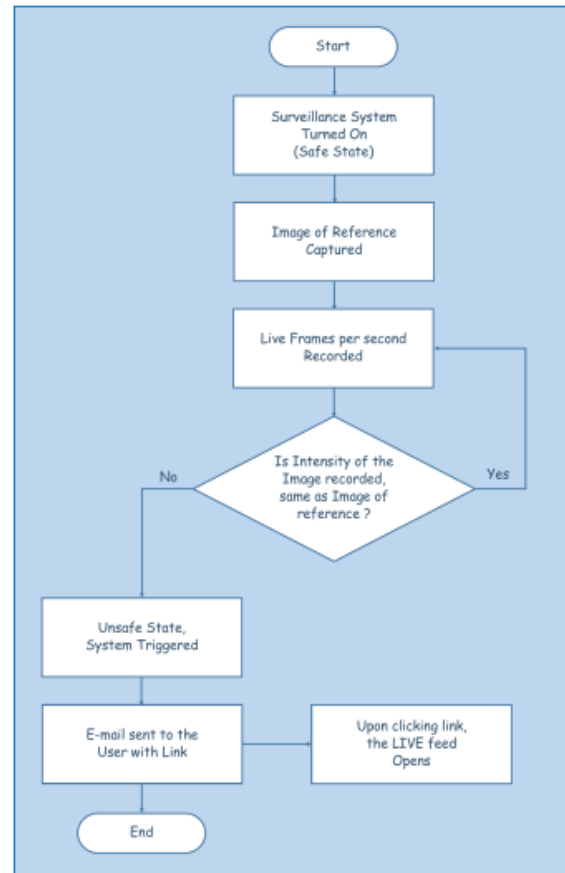

Figure 3. Flowchart of Proposed Model

IV. CONCLUSION

Differences is Existing Locks and proposed system-

- In Existing locker system there is no live feedback to the user while in our proposed research work we there is a provision of live feedback to the user.
- In Existing locker system there is no system to avoid theft, after theft we are informed by looking at the CCTV footage while we can prevent the theft by giving the alert to the user in our proposed system.
- In Existing Locker System Privacy issue was the major concern due to which privacy breach is possible while Privacy can be maintained in our

smart locker system by the use of latest advanced technology of IOT.

[5] Ward Li, S., Pom Inc, (1993). Smart Cart and Box System for Parking Meter. U.S. Patent (5,259,491).

Benefits of Proposed Research Work –

- It has advanced security.
- It provides live feed to the users.
- It works with advanced sensors like constant light intensity sensor.
- It detects any kind of change in motion.
- No continuous check to the camera footage is required.
- Alert Notifications are enabled.

Our proposed research paper is an optimal solution because in Existing model we have a CCTV camera which is deployed in an area for security, to avoid any theft but a person is required to continuously check the CCTV and there is also threat to privacy.

But in our proposed system a motion detection camera is deployed inside the smart locker connected to Raspberry Pi, which on any theft or risk send the alert message or notification to the owner of locker which solve the problem of continuous check.

REFERENCES

- [1] S. U. Rasal, R. Agarwal, V. S Rasal, And S. T. Shelar,(Sept.2016),“Iot Appliance Access Structure Using Abe Based Otp Technique,” The Iioab Journal, (Vol. 7, Pp. 180-186).
- [2] Rasal, S.U., Gupta, K., Rasal, V. And Shelar, S., (2017). Auto Motive Refuge Concept Using Embedded and Computing Approches. International Journal of Advanced Research in Computer Science, 8(5).
- [3] Rasal, M.S.U., Agarwal, M.Y., Agarwal, M.R. and Rasal, M.V.S., Securing Iot with Trusted Authority Validation in Homomorphic Encryption Technique with Abe. International Journal on Future Revolution in Computer Science & Communication Engineering. 3(10)
- [4] Suraj U. Rasal, Varsha S. Rasal, Shraddha T. Shelar. (1). Enhancing Security Levels At Isp Server Using Multiple Security Techniques With Proposed Crypo Application. International Journal of Engineering and Technology Innovation. 9 (1), (P49-60).